



KOMPAKT RECU/REGO

Series Air Handling Units

Installation and Maintenance Service Manual

Content

Safety Requirements	4
Transportation	5
Brief Description of the Unit	6
Installation	10
Maintenance space requirement	11
Section Connection	12
Connection of Hot Water Heaters	12
Maintenance	13
Technical Information	15
Ordering Key	18

Safety Requirements



- To avoid accidents and/or unit damage, only a trained technician must carry out the connection.
- The appropriate Personal Protective Equipment (PPE) attire is worn relative to the operation being carried out.
- Electrical equipment is rated, connected and earthed in accordance with CE regulations.

The air handling unit must be plugged in to an electrical outlet (with earth), which is in good order and corresponds with all requirements of electric safety.

Before starting any operations inside the unit, make sure that the unit is switched off, and the power cable is unplugged.



- Earth must be installed according EN61557, BS 7671
- The unit should be installed according to Installation and Maintenance Manual.
- Before starting the unit, check correct position of air filters.
- Service maintenance should be carried out only in conformity with the instructions specified herein below.

Transportation

The air handling units are ready for transit and storage (1 Picture). The unit is packed to prevent damage of the external and internal parts of the unit, dust and moisture penetration.

Corners of the air handling units are protected against the damage – protective corners are used. The entire unit is wrapped up in protective film. For transit or storage, units are mounted on timber pallets. The unit is fastened to the pallet with polypropylene packing tape over protective corners.

Vertical and horizontal units ready for transit and storage

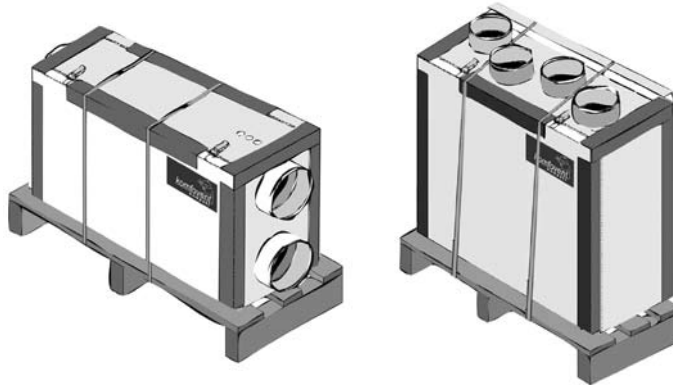

1 Picture

When unit is loaded or unloaded by crane, cargo rope is fastened in its designated places. Forklift truck or hand pallet truck can transport air handling unit as it is shown (2 a, b, c Pictures).

Vertical and horizontal unit transportation by forklift truck, hand pallet truck or crane

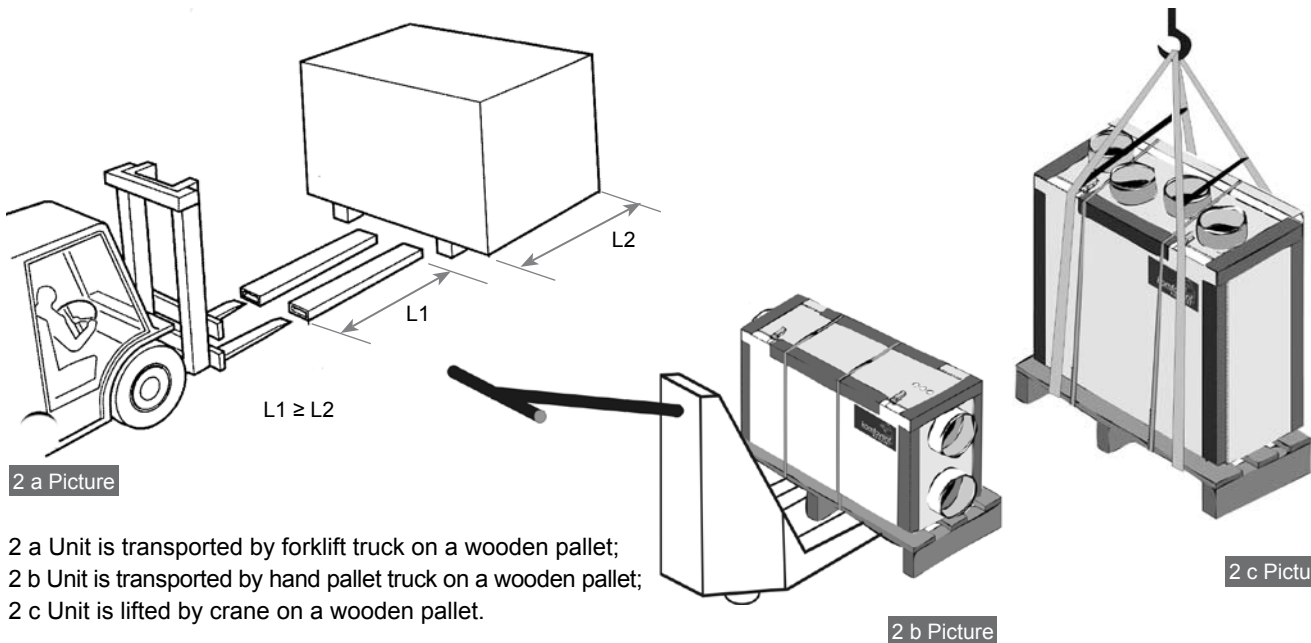

2 a Picture

- 2 a Unit is transported by forklift truck on a wooden pallet;
- 2 b Unit is transported by hand pallet truck on a wooden pallet;
- 2 c Unit is lifted by crane on a wooden pallet.

2 b Picture

2 c Picture

The unit should be examined upon receipt, to ensure that no visible damage has occurred during transit, and the advice note checked to ensure that all items have been received. If damage or delivery shortages are discovered, the carrier should be immediately informed. AMALVA should be notified within three days of receipt, with a written confirmation sent within seven days. AMALVA can accept no responsibility for damage by unloading from carrier or for subsequent damage on site.

If the unit is not to be installed immediately, it should be stored in a clean, dry area. If stored externally, it should be adequately protected from the weather.



Brief Description of the Unit

Casings of air handling units are made of galvanized steel sheets, which are powder painted. Mineral wool is used for thermal insulation and sound attenuation. Unit cover panels are 45 mm thick, except KOMFOVENT KOMPAKT REGO 300VE and RECU 300VE being 25 mm thick.

The air handling units are intended for ventilation of medium-sized spaces (eg. single family houses, offices, etc.), having operating ambient temperature and relative humidity.

KOMFOVENT KOMPAKT REGO is equipped with a rotary heat exchanger, KOMFOVENT KOMPAKT RECU - with plate heat exchanger, which may be replaced with summer cassette, when recuperation is needless, air filters, an electric or water heater, fans and automation control system, to ensure safe and efficient operation of the unit.

KOMFOVENT KOMPAKT REGO Horizontal Air Handling Units Schemes

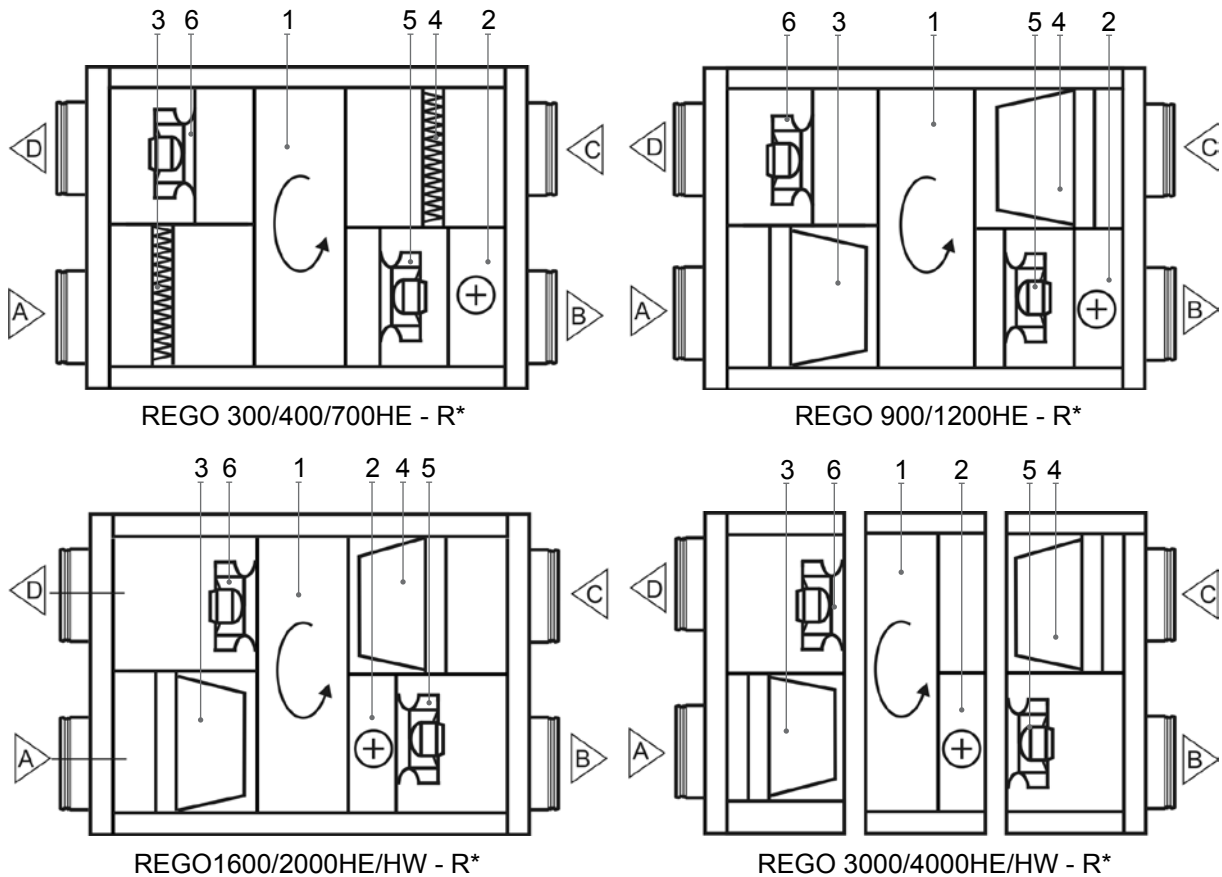

- 1. Rotary heat exchanger
- 2. Air heater (electric or hot water)
- 3. Supply air filter
- 4. Exhaust air filter
- 5. Supply fan
- 6. Exhaust fan

- ▷ Outdoor intake
- ▷ Supply air
- ▷ Extract indoor
- ▷ Exhaust air

* R - right inspection side;
L - left inspection side.

KOMFOVENT KOMPAKT REGO Vertical Air Handling Units Schemes

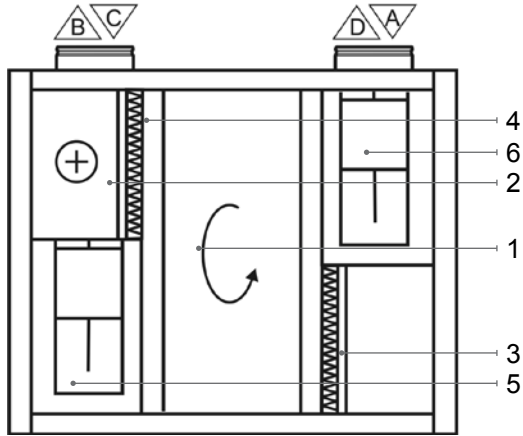

REGO 300VE

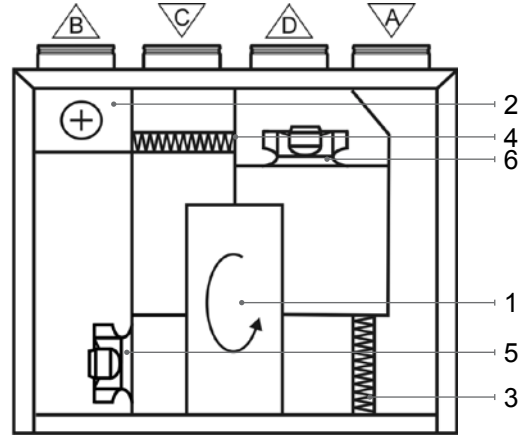

REGO 400/700VE - L*

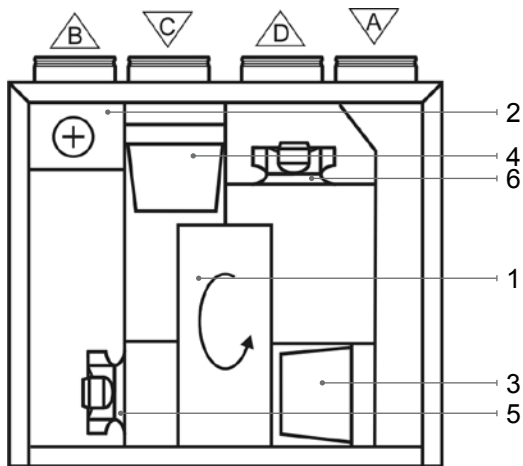

REGO 900/1200VE - L*

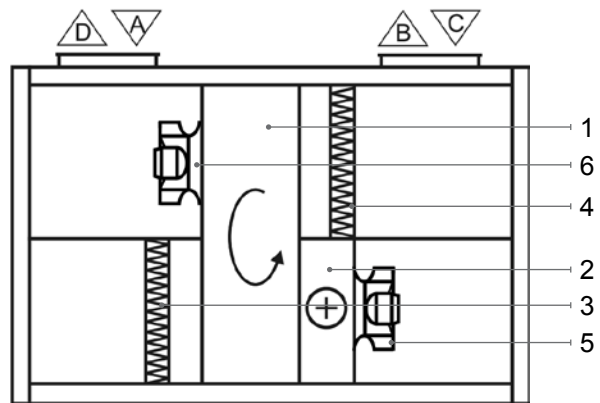



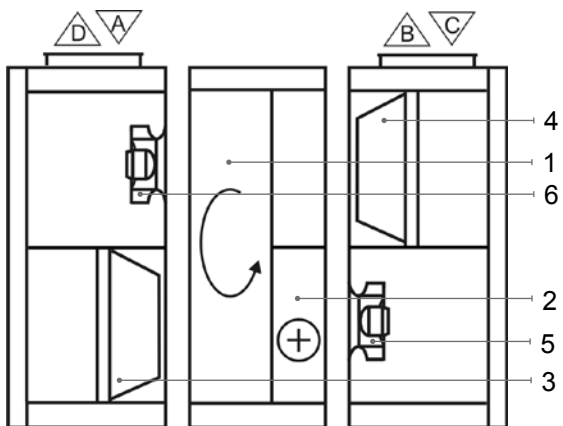

REGO 1600/2000VE - R*



REGO 3000/4000VE - R*

- 1. Rotary heat exchanger
- 2. Air heater (electric or hot water)
- 3. Supply air filter
- 4. Exhaust air filter
- 5. Supply fan
- 6. Exhaust fan

-  Outdoor intake
-  Supply air
-  Extract indoor
-  Exhaust air

4 Picture

* R - right inspection side;
L - left inspection side.



KOMFOVENT KOMPAKT RECU Horizontal Air Handling Units Schemes

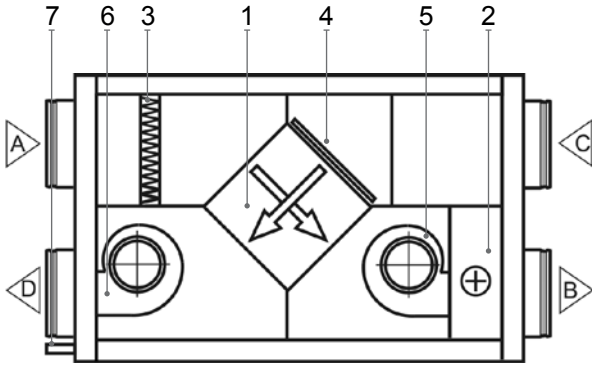

RECUs 400/700/900HE - R*

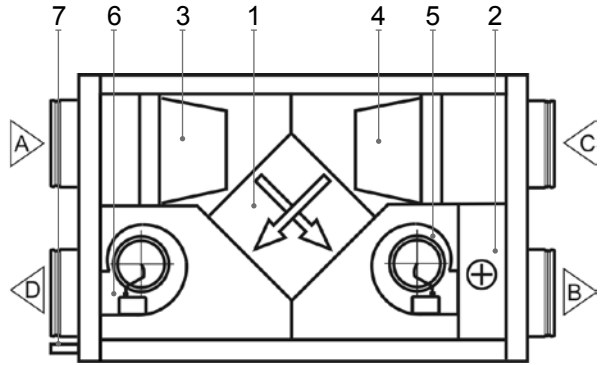

RECUs 1200HE - R*

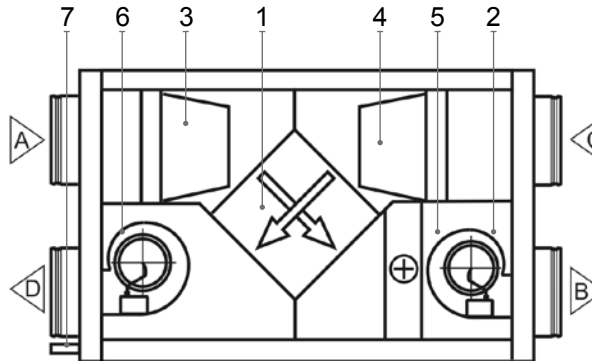

RECUs 1200HW - R*

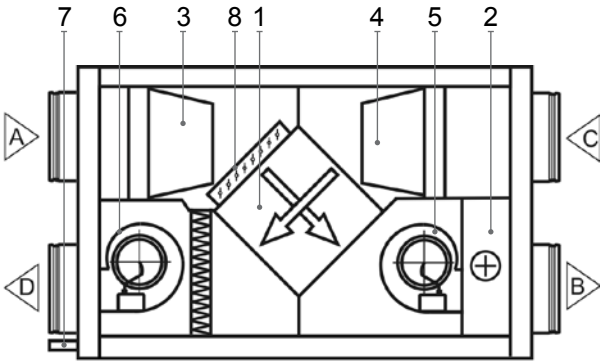

RECUs 1600/2000HE - R*

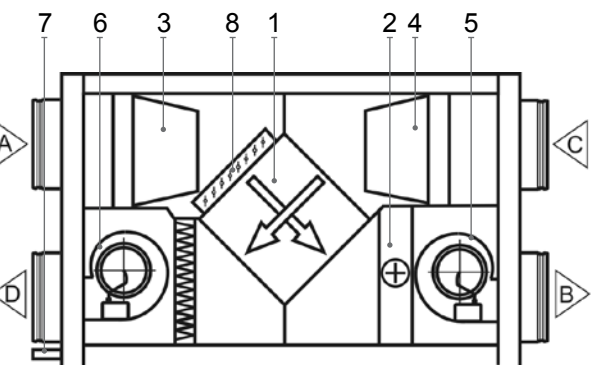

RECUs 1600/2000HW - R*

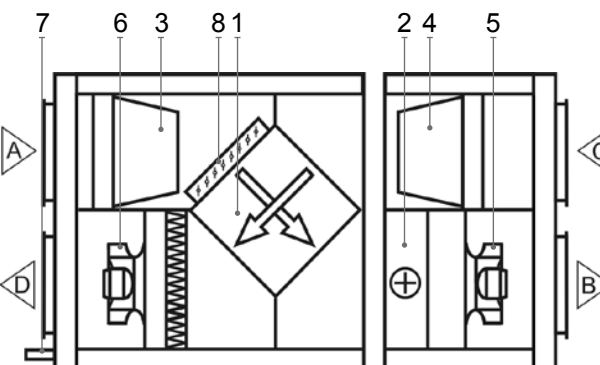

RECUs 3000/4000HE/HW - R*

- 1. Plate heat exchanger
- 2. Air heater (electric or hot water)
- 3. Supply air filter
- 4. Exhaust air filter
- 5. Supply fan
- 6. Exhaust fan
- 7. Condensate drain (the siphon must be installed)
- 8. Air by-pass damper

- △ Outdoor intake
- ▷ Supply air
- ◁ Extract indoor
- ▽ Exhaust air

* R - right inspection side;
L - left inspection side.

5 Picture



Installation

Unit Installation Scheme

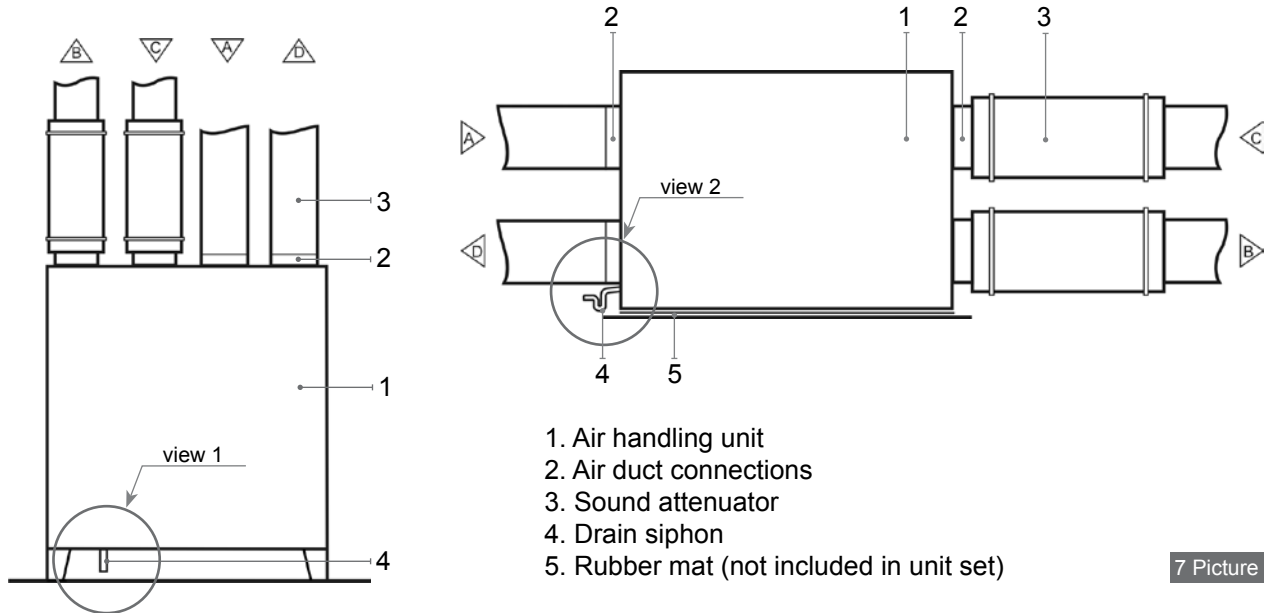

Condensate Drain Connections

All condensate drain connections must be correctly trapped. Incorrect trapping can result in flooding within the unit and consequent flooding of the immediate area. Fill the drain trap with water before starting up the unit.

All drain lines should be insulated where passing through any space where damage from condensation drip might occur. If the unit is installed in unheated premises the condensate pipe should be heat-insulated and heated with heating cable.

A condensate pipe and a drain trap

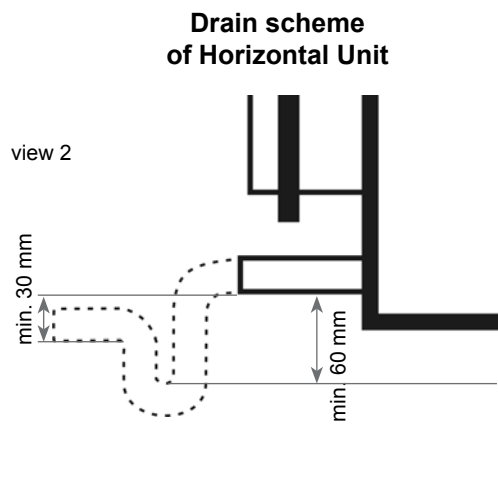
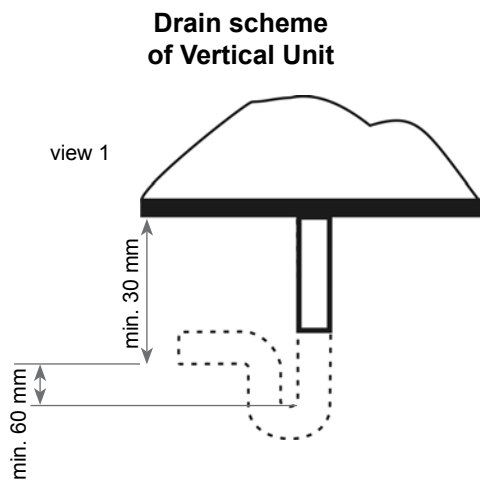

Maintenance space requirements

It is recommended to install the air handling unit in a separate room or in the attic on a hard smooth surface insulated with a rubber mat. The place for the unit should be selected with allowance for minimum access to the unit for maintenance and service inspection. The minimum free space in front of the control panel should be not less than 700 mm. The free space over the top of the unit should be at least 300 mm (9 a, b Picture).

Rubber mat must be used when unit is going to be mounted on the wall.

Minimum maintenance space for horizontal units

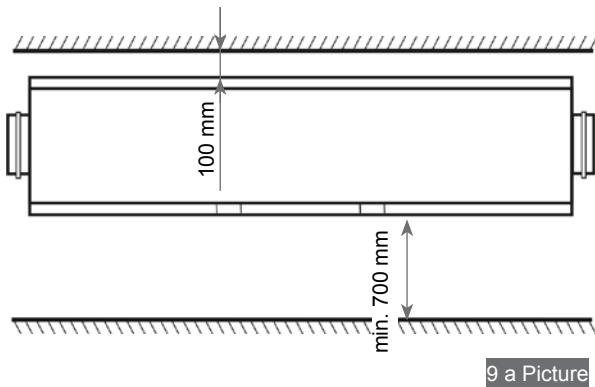

Minimum maintenance Space for the Vertical Units

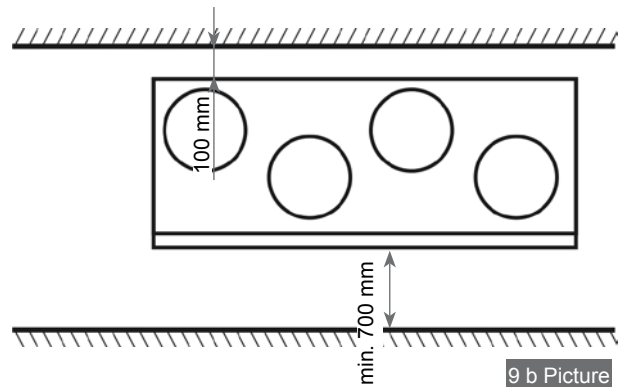

Ductwork

The air flows in/out air handling unit through ductwork. We recommend using galvanized steel (Zn 275 gr/m²) ductwork, to ensure easy cleaning and durability. It is necessary to use the ductwork system with low air flow rate and small pressure drop to have necessary air volume and low sound level and save the energy. The appropriate sound attenuators will reduce the noise level of the fans in the premises.

All ductwork should be insulated with 50–100 mm thickness insulation to avoid the condensation.

Note: temperature sensor B1 has to be mounted in the supply air duct under electric heater (see the functional diagram in Control System Installation and Operation Manual). It is necessary to leave space in straight air duct for sensor mounting and guarantee the space for maintenance and service work. Minimal space between the unit and B1 sensor is the space of double air duct diameter.

 Ductwork, steelwork and any other services should not be supported off the unit.

Section-to-section joints

Ensure that sections or section assemblies are positioned in their proper sequence and that the unit handling and reference is correct. Sections should be accurately aligned prior to bolting together using the fixings and gas-gaskets provided. The sealing gasket and fastening parts are available with every air handling unit.

Incorrect installation will result in air leakage, air blow marks to the unit casings and unacceptable noise. Section connection scheme is shown in 10 Picture.

Section Connection Scheme

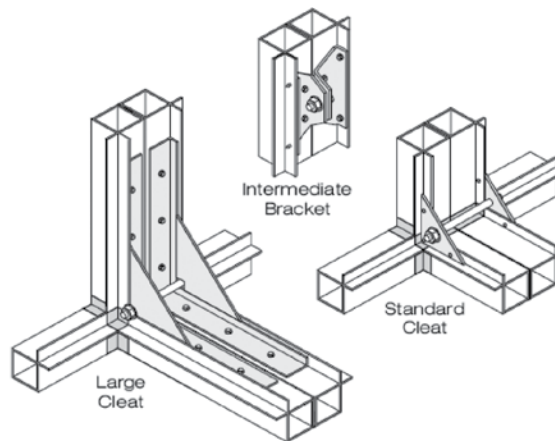

10 Picture

Heating coil connection*

Pipe work should be connected in accordance with good engineering practice. All pipe work must be adequately supported to ensure that no additional load is stressing the unit.

Mounting the pipes on the heating coil, tight the pipes with spanners. As shown in 11 Picture.

Fitting Pipes Connection

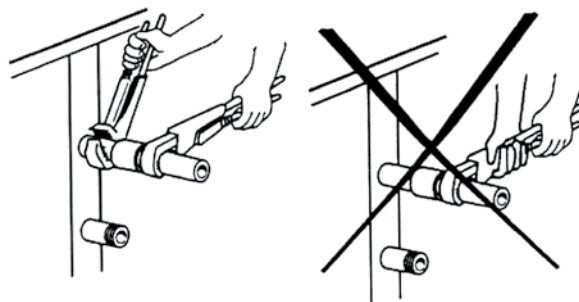

11 Picture

The pipe work should be done in order to ensure the space for maintenance and service work. When carrying out the installation of heater pipes, make sure that hot water supply is completely disconnected. Before start-up of the air handling unit, the heater system should be filled in with water.

*If water heater build in.

Final Inspection

After installation of the unit, a thorough inspection should be carried out. This should include inspecting the inside of the unit and removing debris and tools, which may have been left behind by on site contractors. Replace any panels, which may have been removed and close all access doors, ensuring that the door sealing gaskets have not been damaged.

Maintenance

It is recommended to carry out routine maintenance of the air handling unit KOMFOVENT KOMPAKT REGO/RECU 3 – 4 times per year.

Besides preventive maintenance inspection, the following operations should be performed:

- 1. Rotary heat exchanger check.** Inspection of the rotary heat exchanger is performed once per year. Free rotation of the rotary heat exchanger, continuity of the rotating belt, absence of damages of the rotor drums and the seal gasket are checked. It is necessary to check the stretch of belt. Free belt will slide and the efficiency of rotary heat exchanger will fall down. To reach maximal efficiency, rotor must turn at least 8 times per minute. Polluted heat exchanger will decrease efficiency. Clean heat exchanger with an air blast or wash with tepid water. Check out water falling on the electric motor.
- 2. Plate heat exchanger check.** Inspection and dedusting of the plate heat exchanger is performed once per year (it is removed from the unit and blown with an air blast or washed with tepid water).
Note: plate heat exchanger may be replaced with summer cassette, when recuperation is needless.
- 3. Fans check** (once per year). Polluted fans decrease efficiency.



Before performing any inspection work, check whether the unit is switched off from the electric power supply.

Fans should be carefully cleaned with textile or soft brush. Do not use water. Do not break balance. Check if direction of fan turns is right, because wrong direction of turns gives only 30% rating. Check if fan freely rotates and is not mechanically damaged, if impeller does not touch suction nozzles, fan does not spread noise, the pressure tubes are connected to the nozzle (if it is required), mounting bolts are screwed.

The rubber couplings connecting the motor base and the unit should be visually inspected for signs of wear and replaced as necessary.

Any unusual noise or vibration when the fan is running should be immediately investigated, as this usually an indication of wear or imbalance in the fan system.

- 4. Air heater check.** Recommended to perform periodical inspection and cleaning of heater. Check the plates of water air heater. The air heater is cleaned with hoover from supply air side or with air blast from exhaust air side. If it is very dirty, wash with tepid water, which will not make corrosion of aluminium. Check if position of return water temperature sensor is right. Check if electric air heater is properly fixed, wires connections are not damaged and heating elements are not bent. They can be damaged or bent due to uneven heat or uneven and turbulent air direction. Check if electric air heater is clear of unnecessary things and heating elements are not clogged, because this can cause unpleasant smell or in the worst case – dust can start burning. Air flow through the air heater should be greater than 1,5 m/s. Heating elements can be cleaned with hoover or wet textile.
- 5. Air damper check (if it is required).** Not fully opened outside air damper rises up the pressure in the system. Water air heater can freeze if outside air damper does not fully close in not working air handling unit. Mounting and running of air damper should be checked and regulated.

6. Air filter clogging check. Change air filters when air filter clogging is indicated. We recommend to change filters at least twice per year: before and after heating season, or more*.

If air handling unit is working in small speed, the filters must be checked on unit maximum speed. Filters are one time used. We do not recommend cleaning them. Stop the air handling unit before changing filters.

Pressure sensor

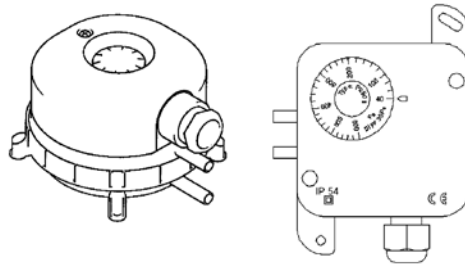

12 Picture

7. Pressure sensor setting, which indicates impurity of filters. Pressure sensor is set according to EN 13779:2007 standard: 100 Pa for small systems, 150 Pa for big systems. Remove cover from the pressure sensor and turn the cursor due to proper position. The indicator will turn on when filters will be clogged.

- One of pressure sensors shown in 12 Picture can be mounted in the air handling unit.
- Close the door after pressure sensor regulating process. Be sure that sensor does not indicate impurity of clear filters.
- Pressure sensors in the air handling units up to size 900 are regulated and set in factory.

* *Clogged filters unbalance ventilation system, air handling unit uses more power.*

Technical Information

Dimensions of HE

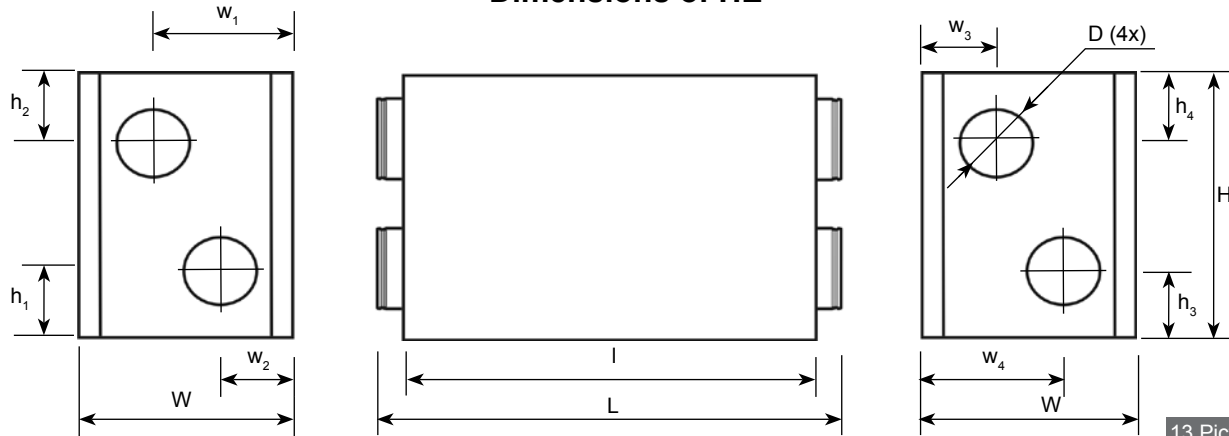

13 Picture

Dimensions of VE

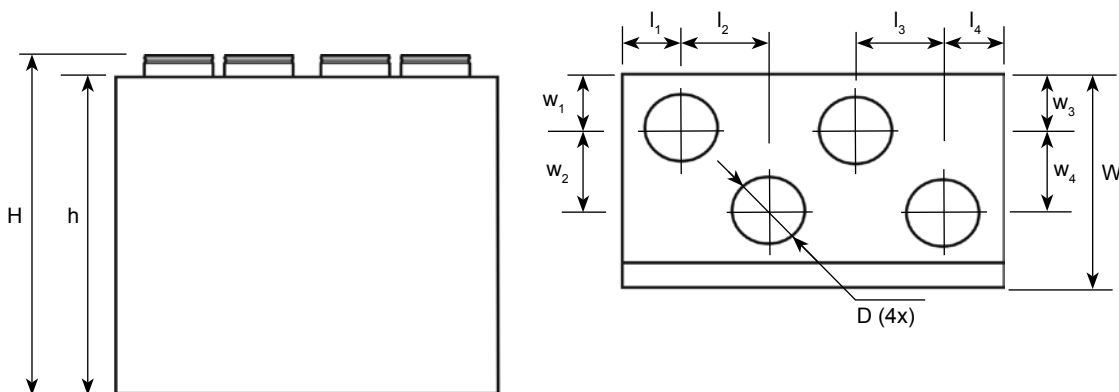

14 Picture

Type	Parameters	Dimensions			Weight	Supply voltage	Operating current	Heater capacity		Fans input power	Ducts connection D
		Width, W	Length, L/I (L ₁ , L ₂ , L ₃)*	Height, H/h				Hot water	Electric		
REGO											
300VE		470	600	560/490	40	1~ 230	5,8		1	2*135	160
300HE-EC		510	790/640	580	60	1~ 230	5,7		1	2*77	160
400HE		635	1080/930	700	90	1~ 230	5,8		1	2*135	200
400VE		635	1060	1125/1050	140	1~ 230	5,8		1	2*135	200
700HE		635	1080/930	700	90	1~ 230	11		2	2*240	250
700VE		635	1060	1125/1050	140	1~ 230	11		2	2*240	200
900HE-AC		795	1550/1400	795	165	3~ 230***	6,6		3	2*230	250
900HE-EC		795	1550/1400	795	165	3~ 230***	9,4		3	2*400	250
900VE-AC		795	1250	1345/1270	175	3~ 230***	6,6		3	2*230	250
900VE-EC		795	1250	1345/1270	175	3~ 230***	9,4		3	2*400	250
1200HE-EC		795	1550/1400	795	170	3~ 230***	12		4,5	2*400	315
1200VE-EC		795	1250	1345/1270	180	3~ 230***	12		4,5	2*400	250
1600HE-AC		900	1650/1500	990	280	3~ 230***	14		4,5	2*485	315
1600HE-EC		900	1650/1500	990	280	3~ 230***	12,8		4,5	2*485	315
1600HW-AC		900	1650/1500	990	280	1~ 230	8	6,5		2*485	315

Parameters Type	Dimensions			Weight kg	Supply voltage V	Opera- ting current A	Heater capaci- ty		Fans input power W	Ducts connec- tion D mm
	Width, W mm	Length, L/l (L ₁ , L ₂ , L ₃)* mm	Height, H/h mm				Hot water kW**	Elec- tric kW		
	1600HW-EC	900	1650/1500				990	280		
1600VE-AC	900	1500	1020/990	270	3~ 230***	14		4,5	2*485	400*300
1600VE-EC	900	1500	1020/990	270	3~ 230***	12,1		4,5	2*485	400*300
1600VW-AC	900	1500	1020/990	275	1~ 230	8	6,5		2*485	400*300
1600VW-EC	900	1500	1020/990	275	1~ 230	6,8	6,5		2*485	400*300
2000HE-AC	900	1650/1500	990	290	3~ 230***	20,3		7,5	2*690	400
2000HE-EC	900	1650/1500	990	290	3~ 230***	17,2		7,5	2*500	400
2000HW-AC	900	1650/1500	990	290	1~ 230	10	10		2*690	400
2000HW-EC	900	1650/1500	990	290	1~ 230	6,8	10		2*500	400
2000VE-EC	900	1500	1020/990	285	3~ 230***	17,2		7,5	2*500	400*300
2000VW-EC	900	1500	1020/990	285	1~ 230	6,8	10		2*500	400*300
3000HE-AC	1150	1860/1800 (615,570,615)	1215	440	3~ 230***	22,1		9	2*1100	600*500
3000HW-AC	1150	1860/1800 (615,570,615)	1215	440	3~ 230***	9,5	12		2*1100	600*500
3000VE-EC	1150	1800 (615,570,615)	1245/1215	440	3~ 400	17,2		9	2*994	400*400
3000VW-EC	1150	1800 (615,570,615)	1245/1215	440	3~ 400	4,7	12		2*994	400*400
4000HE-AC	1150	1860/1800 (615,570,615)	1215	450	3~ 230***	31,7		15	2*1500	600*500
4000HW-AC	1150	1860/1800 (615,570,615)	1215	450	3~ 230***	10,5	20		2*1500	600*500
4000VE-EC	1150	1800 (615,570,615)	1245/1215	450	3~ 400	26		15	2*996	400*400
4000VW-EC	1150	1800 (615,570,615)	1245/1215	450	3~ 400	4,7	20		2*996	400*400
RECU										
300VE	350	640	615/565	38	1~ 230	5,5		1	2*132	125
400HE	390	1150/1000	600	55	1~ 230	13		2,5	2*231	200
400VE	390	900	945/780	62	1~ 230	13		2,5	2*231	160
700HE	490	1320/1170	600	75	1~ 230	11,4		2	2*290	250
700VE	490	1000	1115/950	85	1~ 230	11,4		2	2*290	200
900HE	490	1320/1170	600	78	3~ 400	10,3		4,5	2*390	250
900VE	490	1000	1115/950	90	3~ 400	10,3		4,5	2*390	200
1200HE	700	1820/1670	860	195	3~ 400	13,9		6	2*490	315
1200HW	700	1820/1670	860	200	1~ 230	5,7	10		2*490	315
1200VE	700	1360	1535/1300	225	3~ 400	13,9		6	2*490	250
1600HE	700	2050/1900	900	320	3~ 400	26,6		12	2*650	315/400
1600HW	700	2050/1900	900	330	1~ 230	9,7	20		2*650	315/400
1600VE	700	1470	1510/1310	300	3~ 400	26,6		12	2*650	250
1600VW	700	1470	1510/1310	290	1~ 230	9,2	20		2*650	250
2000HE	700	2050/1900	900	325	3~ 400	38,8		18	2*830	315/400
2000HW	700	2050/1900	900	330	1~ 230	13,3	20		2*830	315/400
3000HE	790	2715/2655 (1770,885)	1365	530	3~ 400	34,7		18	2*1100	600*500
3000HW	790	2715/2655 (1770,885)	1365	540	3~ 400	9,1	20		2*1100	600*500
4000HE	790	2860/2800 (1770, 1030)	1365	605	3~ 400	43,4		24	2*1100	600*500
4000HW	790	2860/2800 (1770, 1030)	1365	605	3~ 400	9,1	40		2*1100	600*500

Parameters with nominal air volume, $t_{\text{outside}} = -23^{\circ}\text{C}$, $t_{\text{inside}} = 22^{\circ}\text{C}$

* (L₁, L₂) – sectional unit

** parameters of hot water 80-60°C, connection REGO – 1/2", REGO 4000HW/VW and RECU 1"

*** 3 x 230V is available as an option

Dimensions of Ductwork Connection

Type	Parameters	w ₁	w ₂	w ₃	w ₄	l ₁	l ₂	l ₃	l ₄	h ₁	h ₂	h ₃	h ₄
		mm	mm	mm	mm	mm	mm	mm	mm	mm	mm	mm	mm
REGO													
300VE		110	235	120	225	106	0	0	106	-	-	-	-
300HE-EC		310	150	310	150	-	-	-	-	160	205	160	205
400HE/700HE		390	245	245	390	-	-	-	-	220	175	175	220
400 VE/700VE		220	195	220	195	145	250	250	145	-	-	-	-
900HE-AC/EC		500	300	300	500	-	-	-	-	245	200	200	245
900VE-AC/EC		265	265	265	265	170	285	285	170	-	-	-	-
1200HE-EC		500	300	300	500	-	-	-	-	245	200	200	245
1200VE-EC		265	265	265	265	170	285	285	170	-	-	-	-
1600/2000HE/W-AC/EC		450	450	450	450	-	-	-	-	245	245	245	245
1600/2000VE/W-AC/EC		230	400	230	400	275	0	275	0	-	-	-	-
3000/4000HEW-AC		575	575	575	575	-	-	-	-	295	295	295	295
3000/4000VE/W-EC		275	550	275	550	275	0	275	0	-	-	-	-
RECU													
300VE		110	130	110	130	95	148	148	95	-	-	-	-
400HE		195	195	195	195	-	-	-	-	145	145	145	145
400VE		150	90	150	90	145	200	200	145	-	-	-	-
700HE		245	245	245	245	-	-	-	-	145	160	145	160
700VE		170	130	170	130	160	210	210	160	-	-	-	-
900HE		245	245	245	245	-	-	-	-	145	160	145	160
900VE		170	130	170	130	160	210	210	170	-	-	-	-
1200HE/HW		350	350	350	350	-	-	-	-	220	200	220	200
1200VE		250	200	250	200	210	300	300	210	-	-	-	-
1600/2000HE/W		350	350	350	350	-	-	-	-	240	200	240	200
1600VE/W		240	220	240	220	195	355	355	195	-	-	-	-
3000/4000HE/W		395	395	395	395	-	-	-	-	350	350	350	350

Filters

Unit	Type	Overall dimensions			Supply	Exhaust
		Type	Width	Height	Length	Length
REGO	300	PF5-PF7*	410	200	24	24
REGO	400/700	PF5-PF7*	540	260	46	46
REGO	900/1200	BF5	592	287	360	360
REGO	1600/2000 V	PF5	792	392	46	46
REGO	1600/2000 H	PF5-PF7*	792	392	360	360
REGO	3000/4000	BF5	892	490	300	300
RECU	300	PF5/MG4	300	150/300	24	5
RECU	400	PF5-PF7*/MG4	290/295	195/305	46	5
RECU	700/900	PF5-PF7*/MG4	390/395	235/300	46	5
RECU	1200/1600/2000	BF5/BG4	592	287	360	360
RECU	3000/4000	BF5/BG4	592	592	300	300
Supply/Exhaust air						
PF5	Panel, class F5		BG4	Bag filter, class G4		
BF5	Bag filter, class F5		MG4	Filter material, class G4		

* - F7 class filter is available as an option



Ordering Key

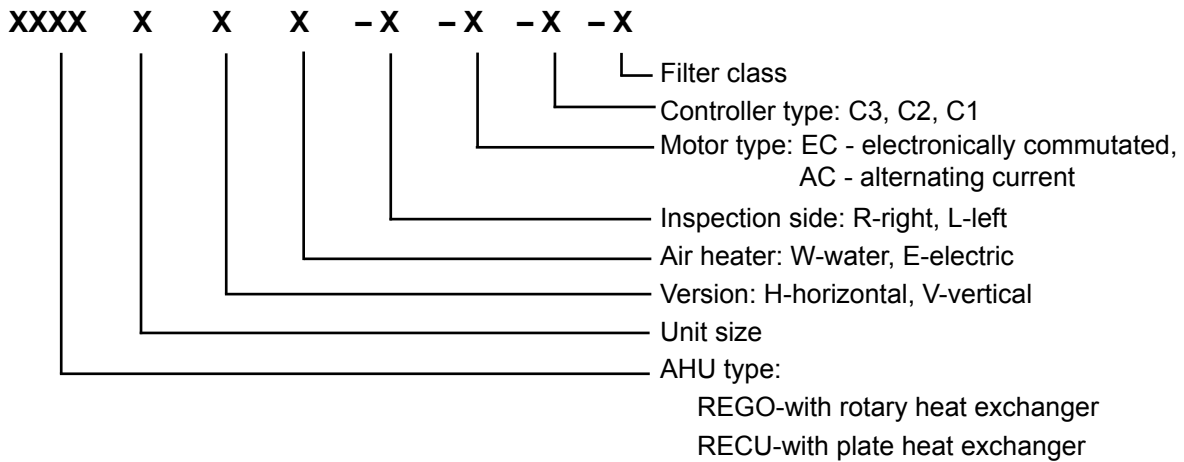

Ordering sample:

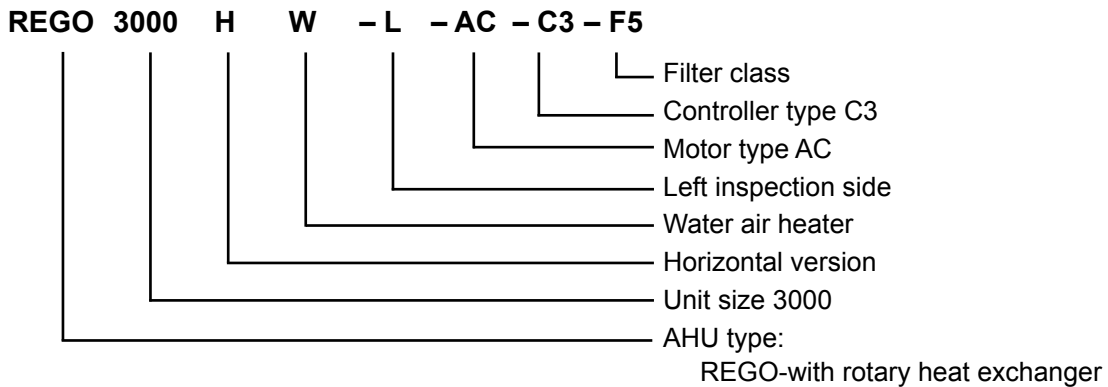

Determination of Inspection side:

- Right side: Looking to Air Handling Unit from inspection door side, supply air fan is on the right side.
- Left side: Looking to Air Handling Unit from inspection door side, supply air fan is on the left side.



Limited Warranty Coupon

The seller fills up

Stick the label here

Quality control performed by:		Stamp
Signature		
Warranty term	24 months*	
Date of purchasing		

The customer fills up

Complete and ready for use product with the manual instruction for it was got. I became acquainted with the warranty conditions and accept them:

Customer signature	
---------------------------	--

**refer to "Warranty conditions"*

Dear purchaser,

Company AMALVA thanks you for your choice. Especially big attention is paid to the quality of the equipment; therefore we would appreciate all your comments and offers concerning technical and operational features of the equipment.

In case of occurrence of any problems we recommend to contact immediately the nearest AMALVA branch office, or to turn to your service company which performed installation, commissioning or technical maintenance works. Address and telephone number is indicated in the warranty coupon.

In order to prevent misunderstanding we ask to acquaint closely with the equipment manual instruction and to check up correctness of filling up the warranty coupon. Unit serial number printed on the metal label fastened to the unit must correspond to that one specified in the warranty coupon.

The warranty coupon is valid only if the model of the equipment, its serial number, date of sale is correctly specified in it; safety sticker of electrical connection box is not damaged; there are precise stamps of the purchaser and the customer's signature. It is forbidden by any way to change, erase or copy the data specified in the warranty coupon - such coupon will be considered void.

By this warranty coupon, Company AMALVA applies the undertakings to implement the requirements of the customers in conformity with THE LAW ON CONSUMERS PROTECTION in case of discovering the defects of the products. Company AMALVA reserves the right to refuse rendering free-of-charge services on warranty service if the warranty conditions specified further are not observed.

Warranty conditions

1. The warranty period of quality of the equipment established by the manufacturer - from the date of purchase of a product. If the purchasing date is not filled in the coupon, then manufacture date is considered to be that date.
2. The warranty is not given:
 - a) if customer can not submit properly and completely filled up warranty coupon;
 - b) if damage occurred or repairs required as a consequence of improper shipping or handling, faulty installation, improper servicing;
 - c) if there are the attributes testifying to attempts to execute unqualified repair;
 - d) in case of detection of equipment construction alteration, not corresponding to requirements of the manufacturer;
 - e) if the equipment is used not according to its direct purpose;
 - f) if serial number indicated on metal label fixed to the equipment is changed or destroyed and is impossible to restore.
3. The guarantee is not given in the following cases of malfunction of the equipment:
 - a) at presence of mechanical damages;
 - b) at presence of damages which reason is hit inside of a product of extraneous subjects, materials, liquids;
 - c) at presence of damages due to floods, winds, fires, lightning, corrosive environments, accidents or other casual external impact, etc.
4. The warranty does not cover normal maintenance as outlined in the manual instruction including cleaning, filters or fuses changing, etc.
5. Company AMALVA does not bear the responsibility for the direct or indirect damage made to people, pets or properties, if the reason of such damage - non-observance of rules and conditions of use and installation of equipment, wilful damage or careless behaviour of the users or the third parties.



UAB AMALVA

Ozo str. 10,
LT-08200 VILNIUS, LITHUANIA
e-mail info@amalva.lt
www.amalva.com
www.komfovent.com