



SMVector - Frequency Inverter **Operating Instructions**



1	Safety Information	3
2	Technical Data	6
2.1	Standards and Application Conditions	6
2.2	SMV Type Number Designation	7
2.3	Ratings	8
3	Installation	11
3.1	Dimensions and Mounting	11
3.1.1	NEMA 1 (IP31)	11
3.1.2	NEMA 4X (IP65)	12
3.1.3	NEMA 4X (IP65) with Disconnect Switch	13
3.2	Electrical Installation	14
3.2.1	Power Connections	14
3.2.1.1	Mains Connection to 120VAC Single-Phase Supply	14
3.2.1.2	Mains Connection to 240VAC Single-Phase Supply	14
3.2.1.3	Mains Connection to Three-Phase Supply	15
3.2.1.4	Motor Connection	15
3.2.1.5	Installation Recommendations for EMC Compliance	15
3.2.1.6	NEMA 4X (IP65) Input Terminal Block	16
3.2.2	Fuses/Cable Cross-Sections	16
3.2.3	Control Terminals	17
4	Commissioning	19
4.1	Local Keypad & Display	19
4.2	Drive Display and Modes of Operation	21
4.3	Parameter Setting	22
4.4	Electronic Programming Module (EPM)	22
4.5	Parameter Menu	23
4.5.1	Basic Setup Parameters	23
4.5.2	I/O Setup Parameters	27
4.5.3	Advanced Setup Parameters	31
4.5.4	PID Parameters	34
4.5.5	Vector Parameters	36
4.5.6	Network Parameters	37
4.5.7	Diagnostic Parameters	38
4.5.7.1	Terminal & Protection Status Display	39
4.5.7.2	Keypad Status Display	39
4.5.8	Onboard Communications Parameters 15-30HP (11.0-22.0kW)	39
5	Troubleshooting and Diagnostics	41
5.1	Status/Warning Messages	41
5.2	Drive Configuration Messages	42
5.3	Fault Messages	43
	Appendix A	46
A.1	Permissible Cable Lengths	46



About These Instructions

This documentation applies to the SMV frequency inverter and contains important technical data regarding the installation, operation, and commissioning of the inverter.

These instructions are only valid for SMV frequency inverters with software revision 2.0 or higher (refer to drive nameplate, an example is shown below).

Please read these instructions in their entirety before commissioning the drive.

A	B	C	D	E	F
 Lenze AC Tech Made in USA Inverter SMV ector	Type: ESV751N04TXB Id-No: 00000000	 INPUT: 3 (3/PE) 400/480 V 2.9/2.5 A 50-60 HZ	OUTPUT: 3 (3/PE) 0 - 400/460 V 2.4/2.1 A 0.75 KW/1HP 0 - 500 HZ	For detailed information refer to instruction Manual: SV01 00000000000000000000 ESV751N04TXB000XX###	
	LISTED 5081 US IND. CONT. EQ.	TYPE-4X INDOOR USE ONLY 			

A	B	C	D	E	F
Certifications	Type	Input Ratings	Output Ratings	Hardware Version	Software Version

Scope of delivery	Important
<ul style="list-style-type: none"> • 1 SMV Inverter with EPM installed (see Section 4.4) • 1 Operating Instructions manual 	<p>After receipt of the delivery, check immediately whether the items delivered match the accompanying papers. Lenze-AC Tech does not accept any liability for deficiencies claimed subsequently.</p> <p>Claim:</p> <ul style="list-style-type: none"> • visible transport damage immediately to the forwarder. • visible deficiencies /incompleteness immediately to your Lenze-AC Tech representative

Copyright © 2006 AC Technology Corporation

All rights reserved. No part of this manual may be reproduced or transmitted in any form without written permission from AC Technology Corporation. The information and technical data in this manual are subject to change without notice. AC Technology Corporation makes no warranty of any kind with respect to this material, including, but not limited to, the implied warranties of its merchantability and fitness for a given purpose. AC Technology Corporation assumes no responsibility for any errors that may appear in this manual.

All information given in this documentation has been carefully selected and tested for compliance with the hardware and software described. Nevertheless, discrepancies cannot be ruled out. AC Technology does not accept any responsibility nor liability for damages that may occur. Any necessary corrections will be implemented in subsequent editions. This document is printed in the United States



1 Safety Information

General

Some parts of Lenze-AC Tech controllers can be electrically live and some surfaces can be hot. Non-authorized removal of the required cover, inappropriate use, and incorrect installation or operation creates the risk of severe injury to personnel and/or damage to equipment.

All operations concerning transport, installation, and commissioning as well as maintenance must be carried out by qualified, skilled personnel who are familiar with the installation, assembly, commissioning, and operation of variable frequency drives and the application for which it is being used.

Installation

Ensure proper handling and avoid excessive mechanical stress. Do not bend any components and do not change any insulation distances during transport, handling, installation or maintenance. Do not touch any electronic components or contacts. This drive contains electrostatically sensitive components, which can easily be damaged by inappropriate handling. Static control precautions must be adhered to during installation, testing, servicing and repairing of this drive and associated options. Component damage may result if proper procedures are not followed.

To ensure proper operation, do not install the drive where it is subjected to adverse environmental conditions such as combustible, oily, or hazardous vapors; corrosive chemicals; excessive dust, moisture or vibration; direct sunlight or extreme temperatures.

This drive has been tested by Underwriters Laboratory (UL) and is UL Listed in compliance with the UL508C Safety Standard. This drive must be installed and configured in accordance with both national and international standards. Local codes and regulations take precedence over recommendations provided in this and other Lenze-AC Tech documentation.

The SMVector drive is considered a component for integration into a machine or process. It is neither a machine nor a device ready for use in accordance with European directives (reference machinery directive and electromagnetic compatibility directive). It is the responsibility of the end user to ensure that the machine meets the applicable standards.

Electrical Connection

When working on live drive controllers, applicable national safety regulations must be observed. The electrical installation must be carried out according to the appropriate regulations (e.g. cable cross-sections, fuses, protective earth [PE] connection). While this document does make recommendations in regards to these items, national and local codes must be adhered to.

The documentation contains information about installation in compliance with EMC (shielding, grounding, filters and cables). These notes must also be observed for CE-marked controllers. The manufacturer of the system or machine is responsible for compliance with the required limit values demanded by EMC legislation.

Application

The drive must not be used as a safety device for machines where there is a risk of personal injury or material damage. Emergency Stops, over-speed protection, acceleration and deceleration limits, etc must be made by other devices to ensure operation under all conditions.

The drive does feature many protection devices that work to protect the drive and the driven equipment by generating a fault and shutting the drive and motor down by removing power. Mains power variances can also result in shutdown of the drive. When the fault condition disappears or is cleared, the drive can be configured to automatically restart, it is the responsibility of the user, OEM and/or integrator to ensure that the drive is configured for safe operation.



Safety Information

Explosion Proof Applications

Explosion proof motors that are not rated for inverter use lose their certification when used for variable speed. Due to the many areas of liability that may be encountered when dealing with these applications, the following statement of policy applies:

AC Technology Corporation inverter products are sold with no warranty of fitness for a particular purpose or warranty of suitability for use with explosion proof motors. AC Technology Corporation accepts no responsibility for any direct, incidental or consequential loss, cost or damage that may arise through the use of AC inverter products in these applications. The purchaser expressly agrees to assume all risk of any loss, cost or damage that may arise from such application.

Operation

Systems including controllers must be equipped with additional monitoring and protection devices according to the corresponding standards (e.g. technical equipment, regulations for prevention of accidents, etc.). The controller may be adapted to your application as described in this documentation.



DANGER!

- After the controller has been disconnected from the supply voltage, live components and power connection must not be touched immediately, since capacitors could be charged. Please observe the corresponding notes on the controller.
- Close all protective covers and doors prior to and during operation.
- Do not cycle input power to the controller more than once every two minutes.
- In SMVector models that come equipped with an optional disconnect switch; the disconnect switch is a motor service disconnect **not** an inverter service disconnect. For servicing of the inverter it is necessary to remove mains power from the inverter and wait 3 minutes before attempting to service the inverter.

Safety Notifications

All safety information given in these Operating Instructions includes a visual icon, a bold signal word and a description.



Signal Word! (characterizes the severity of the danger)

NOTE (describes the danger and informs on how to proceed)

Icon		Signal Words	
	Warning of hazardous electrical voltage	DANGER!	Warns of impending danger. Consequences if disregarded: Death or severe injuries.
	Warning of a general danger	WARNING!	Warns of potential, very hazardous situations. Consequences if disregarded: Death or severe injuries.
	Warning of hot surface and risk of burn	WARNING! Hot Surface	Warns of potential, serious situations. Labels may be on or inside the equipment to alert people that surfaces may reach dangerous temperatures.
	Warning of damage to equipment	STOP!	Warns of potential damage to material and equipment. Consequences if disregarded: Damage to the controller/drive or its environment.
	Information	NOTE	Designates a general, useful note. If observed, then using the controller/drive system is made easier.



Harmonics Notification in accordance with EN 61000-3-2, EN 61000-3-12:

Operation in public supply networks (Limitation of harmonic currents i.a.w. EN 61000-3-2, Electromagnetic Compatibility (EMC) Limits). Limits for harmonic current emissions (equipment input current up to 16A/phase).

Directive	Total Power connected to Mains (public supply)	Additional Measures Required for Compliance ⁽²⁾
EN 61000-3-2	< 0.5kW	with mains choke
	0.5 ... 1kW	with active filter
	> 1kW	complies without additional measures
EN 61000-3-12	16 ... 75amp	Additional measures are required for compliance with the standard

- (1) For compliance with EMC regulations, the permissible cable lengths may change.
- (2) The additional measures described only ensure that the controller meets the requirements of the EN 61000-3-2. The machine/system manufacturer is responsible for the machine's compliance with the regulations.

Safety Information in accordance with EN 61800-5-1:



DANGER! Hazard of Electrical Shock

Capacitors retain charge for approximately 180 seconds after power is removed. Allow at least 3 minutes for discharge of residual charge before touching the drive.



WARNING!

- This product can cause a d.c. current in the PE conductor. Where a residual current-operated (RCD) or monitoring (RCM) device is used for protection in case of direct or indirect contact, only an RCD or RCM Type B is allowed on the supply side of this product.
- Leakage Current may exceed 3.5mA AC. The minimum size of the PE conductor shall comply with local safety regulations for high leakage current equipment.
- In a domestic environment, this product may cause radio interference in which case supplementary mitigation measures may be required.



NOTE

Control and communications terminals provide reinforced insulation when the drive is connected to a power system rated up to 300V rms between phase to ground (PE) and the applied voltage on Terminals 16 and 17 is less than 150VAC between phase and ground.

Control and communications terminals provide basic insulation when the drive is connected to a power system rated up to 300V between phase to ground (PE) and the applied voltage on terminals 16 and 17 is less than 250 VAC between phase phase and ground (PE).

Safety Information in accordance with UL:

Note for UL approved system with integrated controllers: UL warnings are notes which apply to UL systems. The documentation contains special information about UL.



Warnings!

- Suitable for use on a circuit capable of delivering not more than 200,000 rms symmetrical amperes, at the maximum voltage rating marked on the drive.
- Use minimum 75 °C copper wire only.
- Shall be installed in a pollution degree 2 macro-environment.
- NEMA 1 (IP31) models shall be installed in a pollution degree 2 macro-environment.

Torque Requirements (in accordance with UL) are listed in section 3.2.1, Power Connections.



Technical Data

2 Technical Data

2.1 Standards and Application Conditions

Conformity	CE	Low Voltage (2006/95/EC) & EMC (2004/108/EC) Directives
Approvals	UL508C	Underwriters Laboratories -Power Conversion Equipment
Input voltage phase imbalance	≤ 2%	
Humidity	≤ 95% non-condensing	
Temperature range	Transport	-25 ... +70°C
	Storage	-20 ... +70°C
	Operation	-10 ... +55°C (with 2.5%/°C current derating above +40°C)
Installation height	0 - 4000m a.m.s.l. (with 5%/1000 m current derating above 1000m a.m.s.l.)	
Vibration resistance	acceleration resistant up to 1.0g	
 Earth leakage current	> 3.5 mA to PE	
Max Permissible Cable Length ⁽¹⁾	≤ 4.0 Hp (3.0 kW)	30 meters shielded, 60 meters un-shielded
	> 5.0 Hp (3.7 kW)	50 meters shielded, 100 meters un-shielded.
Enclosure	IP31/NEMA 1	IP65/NEMA 4X
Protection measures against	short circuit, earth fault, phase loss, over voltage, under voltage, motor stalling, over temperature, motor overload	
Compliance with EN 61000-3-2 Requirements ⁽²⁾	< 0.5kW	with mains choke
	0.5 ... 1kW	with active filter
	> 1kW	without additional measures
Compliance with EN 61000-3-12 Requirements ⁽²⁾	16 ... 75amp	Additional measures required for compliance with EN 61000-3-12

Operation in public supply networks (Limitation of harmonic currents i.a.w. EN 61000-3-2, Electromagnetic Compatibility (EMC) Limits). Limits for harmonic current emissions (equipment input current up to 16A/phase).

- (1) The stated cable lengths are permissible at default carrier frequencies (refer to parameter P166).
 (2) The additional measures described only ensure that the controller meets the requirements of the EN 61000-3-2. The machine/system manufacturer is responsible for the machine's compliance with the regulations.



2.2 SMV Type Number Designation

The table herein describes the Type numbering designation for the SMVector Inverter models.

Electrical Products in the SMVector Series	ESV	152	NO	2	T	X	B
Power Rating in kW:							
251 = 0.25kW (0.33HP)			113 = 11.0kW (15HP)				
371 = 0.37kW (0.5HP)			153 = 15.0kW (20HP)				
751 = 0.75kW (1HP)			183 = 18.5kW (25HP)				
112 = 1.1kW (1.5HP)			223 = 22.0kW (30HP)				
152 = 1.5kW (2HP)							
222 = 2.2kW (3HP)							
302 = 3.0kW (4HP)							
402 = 4.0kW (5HP)							
552 = 5.5kW (7.5HP)							
752 = 7.5kW (10HP)							
Installed I/O & Communication Module(s):							
C_ = CANopen (Available all models)			The " _ " blank can be:				
D_ = DeviceNet (Available all models)			0 = Standard Keypad				
E_ = Ethernet/IP, ModBus TCP/IP (Avail all models)			N = No Keypad (NEMA 4X / IP65 only)				
R_ = RS-485 / ModBus /Lecom (Avail all models)			P = Potentiometer				
P_ = Profibus-DP (Available all models)							
N_ = No Communications installed (Non-IP20)							
Input Voltage:							
1 = 120 VAC (doubler output) or 240 VAC							
2 = 240 VAC							
4 = 400/480 VAC							
6 = 600 VAC							
Input Phase:							
S = Single Phase Input only							
Y = Single or Three Phase Input							
T = Three Phase Input only							
Input Line Filter							
F = Integral EMC Filter							
L = Integral EMC Filter and Integrated Line Disconnect (NEMA 4X/IP65 Models only)							
M = Integrated Line Disconnect (NEMA 4X/IP65 Models only)							
X = No EMC Filter/No Line Disconnect							
Enclosure:							
B = NEMA 1/IP31; Indoor only							
C = NEMA 4X/IP65; Indoor only; Convection cooled							
D = NEMA 4X/IP65; Indoor only; Fan cooled							
E = NEMA 4X/IP65; Indoor/Outdoor; Convection cooled							
F = NEMA 4X/IP65; Indoor/Outdoor; Fan cooled							



NOTE

Prior to installation make sure the enclosure is suitable for the end-use environment

Variables that influence enclosure suitability include (but are not limited to) temperature, airborne contaminants, chemical concentration, mechanical stress and duration of exposure (sunlight, wind, precipitation).



Technical Data

2.3 Ratings

120V / 240VAC Models

Mains = 120V Single Phase (1/N/PE), 240V Single Phase (2/PE); 48...62Hz									
Type	Power		Mains Current		Output Current		Heat Loss (Watts)		
	Hp	kW	120V A	240V A	Cont (I _n) A	Max I %	N1/IP31	N4X/IP65 No filter	N4X/IP65 W/ filter
ESV251--1S--	0.33	0.25	6.8	3.4	1.7	200	24		
ESV371--1S--	0.5	0.37	9.2	4.6	2.4	200	32	32	
ESV751--1S--	1	0.75	16.6	8.3	4.2	200	52	41	
ESV112--1S--	1.5	1.1	20	10.0	6.0	200	74	74	

NOTES:

Output Current: The Output Current Maximum (%) is a percentage of the Output Current Continuous Amps (I_n) rating and is adjustable in parameter P171.

240VAC Models

Mains = 240V Single Phase (2/PE); 48...62Hz									
Type	Power		Mains Current		Output Current		Heat Loss (Watts)		
	Hp	kW	240V A		Cont (I _n) A	Max I %	N1/IP31	N4X/IP65 No filter	N4X/IP65 W/ filter
ESV251--2S--	0.33	0.25	3.4		1.7	200	20		
ESV371--2S--	0.5	0.37	5.1		2.4	200			30
ESV751--2S--	1	0.75	8.8		4.2	200			42
ESV112--2S--	1.5	1.1	12.0		6.0	200			63
ESV152--2S--	2	1.5	13.3		7.0	200			73
ESV222--2S--	3	2.2	17.1		9.6	200			97

240V Single Phase (2/PE), 240V Three Phase (3/PE); 48...62Hz									
Type	Power		Mains Current		Output Current		Heat Loss (Watts)		
	Hp	kW	1- (2/PE) A	3- (3/PE) A	Cont (I _n) A	Max I %	N1/IP31	N4X/IP65 No filter	N4X/IP65 W/ filter
ESV371--2Y--	0.5	0.37	5.1	2.9	2.4	200	27	26	
ESV751--2Y--	1	0.75	8.8	5.0	4.2	200	41	38	
ESV112--2Y--	1.5	1.1	12.0	6.9	6.0	200	64	59	
ESV152--2Y--	2	1.5	13.3	8.1	7.0	200	75	69	
ESV222--2Y--	3	2.2	17.1	10.8	9.6	200	103	93	



240V Three Phase (3/PE); 48...62Hz									
Type	Power		Mains Current		Output Current		Heat Loss (Watts)		
	Hp	kW	240V A	Cont (I _n) A	Max I %	N1/IP31	N4X/IP65 No filter	N4X/IP65 W/ filter	
ESV112--2T--	1.5	1.1	6.9	6	200	64			
ESV152--2T--	2	1.5	8.1	7	200	75			
ESV222--2T--	3	2.2	10.8	9.6	200	103			
ESV402--2T--	5	4.0	18.6	16.5	200	154	139		
ESV552--2T--	7.5	5.5	26	23	200	225	167		
ESV752--2T--	10	7.5	33	29	200	274	242		
ESV113--2T--	15	11	48	42	180	485			
ESV153--2T--	20	15	59	54	180	614			

NOTES:

Output Current: The Output Current Maximum (%) is a percentage of the Output Current Continuous Amps (I_n) rating and is adjustable in parameter P171.

400...480VAC Models

400 ... 480V Three Phase (3/PE); 48...62Hz											
Type	Power		Mains Current		Output Current				Heat Loss (Watts)		
	Hp	kW	400V A	480V A	Cont (I _n) A		Max I %		N1/IP31	N4X/IP65 No filter	N4X/IP65 W/ filter
					400V	480V	400V	480V			
ESV371--4T--	0.5	0.37	1.7	1.5	1.3	1.1	175	200	23	21	25
ESV751--4T--	1	0.75	2.9	2.5	2.4	2.1	175	200	37	33	37
ESV112--4T--	1.5	1.1	4.2	3.6	3.5	3.0	175	200	48	42	46
ESV152--4T--	2	1.5	4.7	4.1	4.0	3.5	175	200	57	50	54
ESV222--4T--	3	2.2	6.1	5.4	5.5	4.8	175	200	87	78	82
ESV302--4T--	4	3.0	8.3	7.0	7.6	6.3	175	200			95
ESV402--4T--	5	4.0	10.6	9.3	9.4	8.2	175	200	128	103	111
ESV552--4T--	7.5	5.5	14.2	12.4	12.6	11.0	175	200	178	157	165
ESV752--4T--	10	7.5	18.1	15.8	16.1	14.0	175	200	208	190	198
ESV113--4T--	15	11	27	24	24	21	155	180	418		
ESV153--4T--	20	15	35	31	31	27	155	180	493		
ESV183--4T--	25	18.5	44	38	39	34	155	180	645		
ESV223--4T--	30	22	52	45	46	40	155	180	709		

NOTES:

Output Current: The Output Current Maximum (%) is a percentage of the Output Current Continuous Amps (I_n) rating and is adjustable in parameter P171.

For 400...480 VAC models, the output current maximum (%) in the 400V column is used when P107 = 0

For 400...480 VAC models, the output current maximum (%) in the 480V column is used when P107 = 1



Technical Data

600VAC Models

Type	600V Three Phase (3/PE); 48...62Hz							
	Power		Mains Current	Output Current		Heat Loss (Watts)		
	Hp	kW	A	Cont (I _n) A	Max I %	N1/IP31	N4X/IP65 No filter	N4X/IP65 W/ filter
ESV751--6T--	1	0.75	2	1.7	200	37	31	
ESV152--6T--	2	1.5	3.2	2.7	200	51	43	
ESV222--6T--	3	2.2	4.4	3.9	200	68	57	
ESV402--6T--	5	4	6.8	6.1	200	101	67	
ESV552--6T--	7.5	5.5	10.2	9	200	148	116	
ESV752--6T--	10	7.5	12.4	11	200	172	152	
ESV113--6T--	15	11	19.7	17	180	380		
ESV153--6T--	20	15	25	22	180	463		
ESV183--6T--	25	18.5	31	27	180	560		
ESV223--6T--	30	22	36	32	180	640		

NOTES:

Output Current: The Output Current Maximum (%) is a percentage of the Output Current Continuous Amps (I_n) rating and is adjustable in parameter P171.



STOP!

- For installations above 1000m a.m.s.l., derate I_n by 5% per 1000m, do not exceed 4000m a.m.s.l.
- Operation above 40°C, derate I_n by 2.5% per °C, do not exceed 55°C.

Output Current (I_n) derating for Carrier Frequency (P166) for NEMA 1 (IP31) Models:

- If P166=2 (8 kHz), derate I_n to 92% of drive rating
- If P166=3 (10 kHz), derate I_n to 84% of drive rating

Output Current (I_n) derating for Carrier Frequency (P166) for NEMA 4X (IP65) Models:

- If P166=1 (6 kHz), derate I_n to 92% of drive rating
- If P166=2 (8 kHz), derate I_n to 84% of drive rating
- If P166=3 (10 kHz), derate I_n to 76% of drive rating



3 Installation

3.1 Dimensions and Mounting



WARNING!

Drives must not be installed where subjected to adverse environmental conditions such as: combustible, oily, or hazardous vapors; corrosive chemicals; excessive dust, moisture or vibration; direct sunlight or extreme temperatures.

3.1.1 NEMA 1 (IP31)

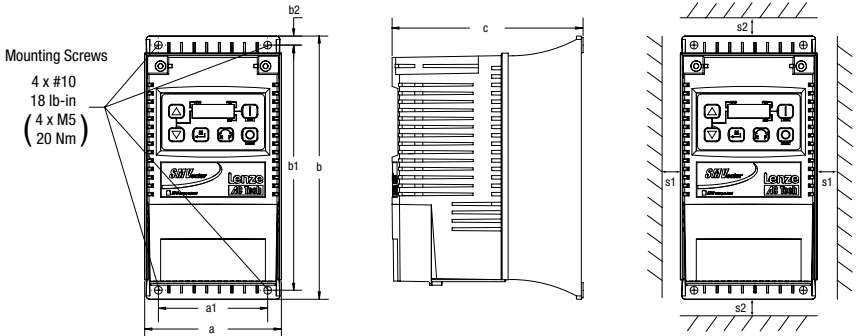

	Type	a in (mm)	a1 in (mm)	b in (mm)	b1 in (mm)	b2 in (mm)	c in (mm)	s1 in (mm)	s2 in (mm)	m lb (kg)
G1	ESV251----B; ESV371----B ESV751----B	3.90 (99)	3.12 (79)	7.48 (190)	7.00 (178)	0.24 (6)	4.35 (111)	0.6 (15)	2.0 (50)	2.0 (0.9)
G2	ESV112----B; ESV152----B ESV222----B	3.90 (99)	3.12 (79)	7.52 (191)	7.00 (178)	0.26 (7)	5.45 (138)	0.6 (15)	2.0 (50)	2.8 (1.3)
G3	ESV402----B	3.90 (99)	3.12 (79)	7.52 (191)	7.00 (178)	0.30 (8)	5.80 (147)	0.6 (15)	2.0 (50)	3.2 (1.5)
H1	ESV552----B; ESV752----B	5.12 (130)	4.25 (108)	9.83 (250)	9.30 (236)	0.26 (7)	6.30 (160)	0.6 (15)	2.0 (50)	6.0 (2.0)
J1	ESV113----B; ESV153----B ESV183----B; ESV223----B	6.92 (176)	5.75 (146)	12.50 (318)	11.88 (302)	0.31 (8)	8.09 (205)	0.6 (15)	2.0 (50)	13.55 (6.15)

Conduit Hole Dimensions	Type	N		P		S		
		in (mm)	in (mm)	in (mm)	in (mm)	in (mm)	in (mm)	
	G1	1.84 (47)	1.93 (49)	.70 (18)	1.00 (25)	.88 (22)		
	G2	1.84 (47)	3.03 (77)	.70 (18)	1.00 (25)	.88 (22)		
	G3	1.84 (47)	3.38 (86)	.70 (18)	1.00 (25)	.88 (22)		
	H1		2.46 (62)	3.55 (90)	.13 (3)	1.38 (35)	1.13 (29)	.88 (22)
		J1	3.32 (84)	4.62 (117)	.73 (19)	1.40 (36)	1.31 (33)	.88 (22)



Installation

3.1.2 NEMA 4X (IP65)

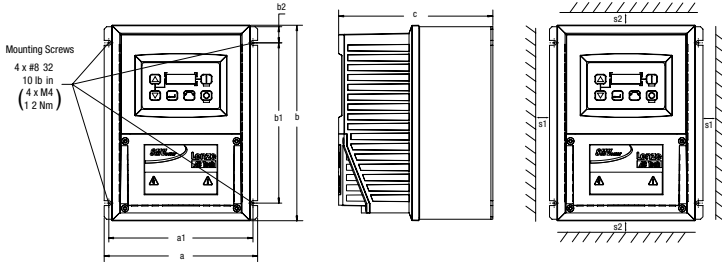

Type	a in (mm)	a1 in (mm)	b in (mm)	b1 in (mm)	b2 in (mm)	c in (mm)	s1 in (mm)	s2 in (mm)	m lb (kg)
R1 ESV371N01SX_ ; ESV751N01SX_ ; ESV371N02YX_ ; ESV751N02YX_ ; ESV371N04TX_ ; ESV751N04TX_ ; ESV751N06TX_ ; ESV371N02SF_ ; ESV751N02SF_ ; ESV371N04TF_ ; ESV751N04TF_ ;	6.28 (160)	5.90 (150)	8.00 (203)	6.56 (167)	0.66 (17)	4.47 (114)	2.00 (51)	2.00 (51)	3.6 (1.63)
R2 ESV112N01SX_ ; ESV112N02YX_ ; ESV152N02YX_ ; ESV112N04TX_ ; ESV152N04TX_ ; ESV222N04TX_ ; ESV152N06TX_ ; ESV222N06TX_ ; ESV112N02SF_ ; ESV152N02SF_ ; ESV112N04TF_ ; ESV152N04TF_ ; ESV222N04TF_ ; ESV302N04TF_ ;	6.28 (160)	5.90 (150)	8.00 (203)	6.56 (167)	0.66 (17)	6.31 (160)	2.00 (51)	2.00 (51)	5.9 (2.68)
S1 ESV222N02YX_ ; ESV222N02SF_ ;	7.12 (181)	6.74 (171)	8.00 (203)	6.56 (167)	0.66 (17)	6.77 (172)	2.00 (51)	2.00 (51)	7.1 (3.24)
T1 ESV552N02TX- ; ESV752N02TX- ; ESV752N04TX- ; ESV752N06TX- ; ESV752N04TF- ;	8.04 (204)	7.56 (192)	10.00 (254)	8.04 (204)	0.92 (23)	8.00 (203)	4.00 (102)	4.00 (102)	10.98 (4.98)
V1 ESV402N02TX_ ; ESV402N04TX_ ; ESV552N04TX_ ; ESV402N06TX_ ; ESV552N06TX_ ; ESV402N04TF_ ; ESV552N04TF_ ;	8.96 (228)	8.48 (215)	10.00 (254)	8.04 (204)	0.92 (23)	8.00 (203)	4.00 (102)	4.00 (102)	11.58 (5.25)

_ = Last digit of part number:

C = N4X Indoor (convection cooled)

E = N4X In/Outdoor (convection cooled)

~ = Last digit of part number: D = N4X Indoor (fan cooled)

F = N4X In/Outdoor (fan cooled)

Conduit Hole Dimensions	Type	N	P	Q	S
		in (mm)	in (mm)	in (mm)	in (mm)
	R1	3.14 (80)	2.33 (59)	1.50 (38)	.88 (22)
	R2	3.14 (80)	4.18 (106)	1.50 (38)	.88 (22)
	S1	3.56 (90)	4.63 (118)	1.50 (38)	.88 (22)
	T1	4.02 (102)	5.00 (127)	1.85 (47)	1.06 (27)
	V1	4.48 (114)	5.00 (127)	1.85 (47)	1.06 (27)



3.1.3 NEMA 4X (IP65) with Disconnect Switch

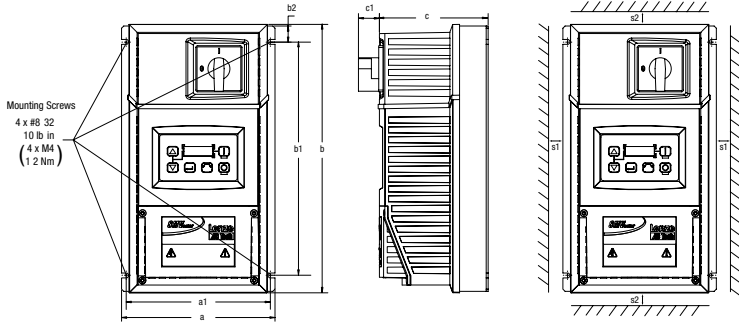

	Type	a in (mm)	a1 in (mm)	b in (mm)	b1 in (mm)	b2 in (mm)	c in (mm)	c1 in (mm)	s1 in (mm)	s2 in (mm)	m lb (kg)
AA1	ESV371N01SM_ ; ESV371N02YM_ ; ESV371N02SL_ ; ESV371N04TM_ ; ESV371N04TL_ ; ESV371N06TM_ ;	6.28 (160)	5.90 (150)	10.99 (279)	9.54 (242)	0.66 (17)	4.47 (114)	.86 (22)	2.00 (51)	2.00 (51)	4.7 (2.13)
	ESV751N01SM_ ; ESV751N02YM_ ; ESV751N02SL_ ; ESV751N04TM_ ; ESV751N04TL_ ; ESV751N06TM_ ;										
	ESV112N01SM_ ; ESV112N02YM_ ; ESV112N02SL_ ; ESV112N04TM_ ; ESV112N04TL_ ; ESV112N02YM_ ;										
	ESV152N02SL_ ; ESV152N04TM_ ; ESV152N04TL_ ; ESV152N06TM_ ; ESV222N04TM_ ; ESV222N04TL_ ; ESV222N06TM_ ; ESV302N04TL_ ;										
	ESV222N02SL_ ; ESV222N02YM_ ;										
AB1	ESV552N02TM- ; ESV752N02TM- ; ESV752N04TM- ; ESV752N06TM- ; ESV752N04TL-	8.04 (204)	7.56 (192)	13.00 (330)	11.04 (280)	0.92 (23)	8.00 (203)	.86 (22)	4.00 (102)	4.00 (102)	13.9 (6.32)
AC1	ESV402N02TM_ ; ESV402N04TM_ ; ESV552N04TM_ ; ESV402N06TM_ ; ESV552N06TM_ ; ESV402N04TL_ ; ESV552N04TL-	8.96 (228)	8.48 (215)	13.00 (330)	11.04 (280)	0.92 (23)	8.04 (204)	.86 (22)	4.00 (102)	4.00 (102)	14.7 (6.66)

_ = Last digit of part number:

C = N4X Indoor (convection cooled)

E = N4X In/Outdoor (convection cooled)

~ = Last digit of part number: D = N4X Indoor (fan cooled)

F = N4X In/Outdoor (fan cooled)

Conduit Hole Dimensions	Type	Conduit Hole Dimensions			
		N in (mm)	P in (mm)	Q in (mm)	S in (mm)
	AA1	3.14 (80)	2.33 (59)	1.50 (38)	.88 (22)
	AA2	3.14 (80)	4.18 (106)	1.50 (38)	.88 (22)
	AD1	3.56 (90)	4.63 (118)	1.50 (38)	.88 (22)
	AB1	4.02 (102)	5.00 (127)	1.85 (47)	1.06 (27)
	AC1	4.48 (114)	5.00 (127)	1.85 (47)	1.06 (27)



Installation

3.2 Electrical Installation

3.2.1 Power Connections



DANGER! Hazard of electrical shock!

Circuit potentials up to 600 VAC are possible. Capacitors retain charge after power is removed. Disconnect power and wait at least three minutes before servicing the drive.



STOP!

- Verify mains voltage before connecting to drive.
- Do not connect mains power to the output terminals (U,V,W)! Severe damage to the drive will result.
- Do not cycle mains power more than once every two minutes. Damage to the drive will result.

Mains and Motor Terminations			
Type	Torque	Strip Length	
<5HP	12 lb-in (1.3 Nm)	0.25 in (6mm)	
ESV552xx2T, ESV752xx2T, ESV113xx4/6, ESV153xx4/6, ESV183xx6, ESV223xx6	16 lb-in (1.8 Nm)	0.25 in (6mm)	
ESV552xx4Txx, ESV752xx4Txx, ESV552xx6Txx, ESV752xx6Txx	12 lb-in (1.3Nm)	0.25 in (6mm)	
ESV113xx2xxx, ESV153xx2xxx, ESV183xx4xxx, ESV223xx4xxx	24 lb-in (2.7 Nm)	0.25 in (6mm)	
Torque: N4X/IP65 Door Screws			
N4X/IP65	6-7 lb-in (0.67-0.79 Nm)	0.25 in (6mm)	

3.2.1.1 Mains Connection to 120VAC Single-Phase Supply

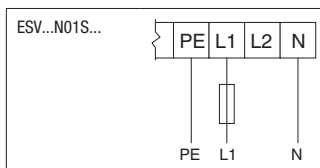

3.2.1.2 Mains Connection to 240VAC Single-Phase Supply

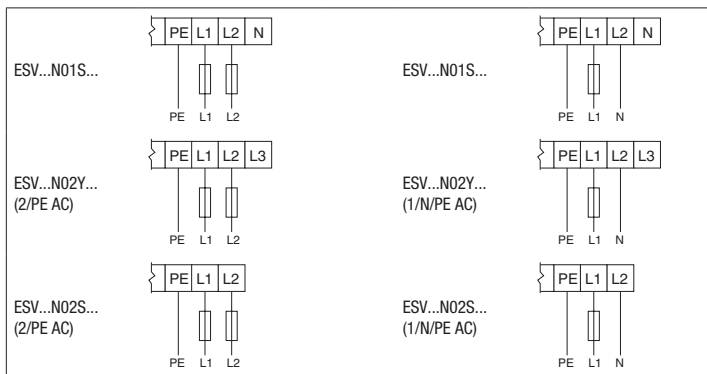



3.2.1.3 Mains Connection to Three-Phase Supply

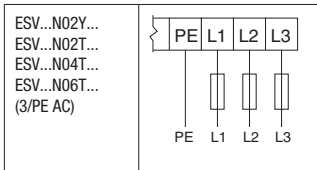

3.2.1.4 Motor Connection

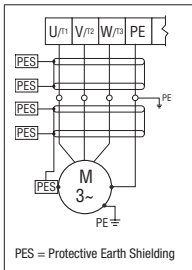

WARNING!

If the cable connection between the drive and the motor has an in-line contactor or circuit breaker then the drive must be stopped prior to opening/closing the contacts. Failure to do so may result in Overcurrent trips and/or damage to the inverter.



WARNING!

Leakage current may exceed 3.5 mA AC. The minimum size of the protective earth (PE) conductor shall comply with local safety regulations for high leakage current equipment.

3.2.1.5 Installation Recommendations for EMC Compliance

For compliance with EN 61800-3 or other EMC standards, motor cables, line cables and control or communications cables must be shielded with each shield/screen clamped to the drive chassis. This clamp is typically located at the conduit mounting plate.

Motor cable should be low capacitance (core/core <75pF/m, core/shield <150pF/m). Filtered drives can meet the class A limits of EN 55011 and EN 61800-3 Category 2 with this type of motor cable up to 10 meters. **NOTE:** Refer to Appendix A for recommended cable lengths. Any external line filter should have its chassis connected to the drive chassis by mounting hardware or with the shortest possible wire or braid.

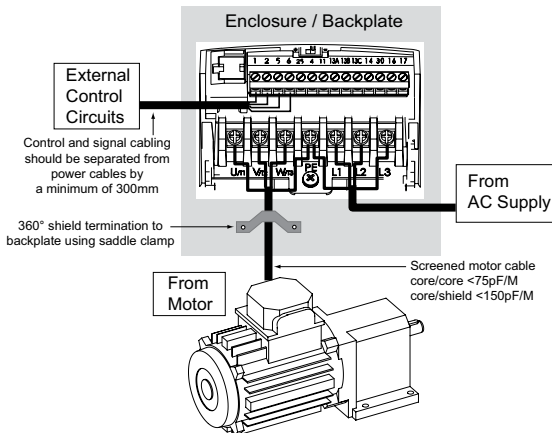



Installation

3.2.1.6 NEMA 4X (IP65) Input Terminal Block

For NEMA 4X (IP65) models with integrated EMC filter and/or integrated line disconnect, the input terminal block is located on the right-hand side of the SMV inverter in the NEMA 4 X (IP65) enclosure. The single and three phase models are illustrated herein. Refer to paragraph 3.2.3 Control Terminals for pin out information.

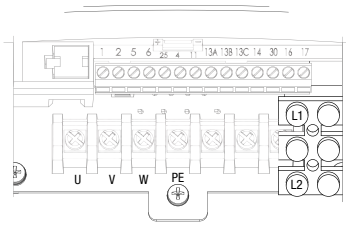

Single Phase (2/PE)
With Filter and/or integrated line disconnect

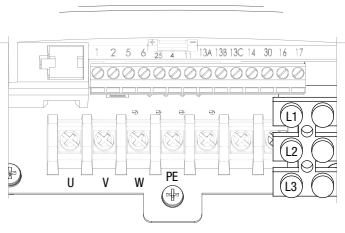

Three Phase (3/PE)
With Filter and/or integrated line disconnect

3.2.2 Fuses/Cable Cross-Sections



NOTE

Observe local regulations. Local codes may supersede these recommendations

Type		Recommendations				
		Fuse	Miniature circuit breaker ⁽¹⁾	Fuse ⁽²⁾ or Breaker ⁽³⁾ (N. America)	Input Power Wiring (L1, L2, L3, PE)	
					[mm ²]	[AWG]
120V 1- (1/N/PE)	ESV251N01SXB	M10 A	C10 A	10 A	1.5	14
	ESV371N01SXB, ESV371N01SX*	M16 A	C16 A	15 A	2.5	14
	ESV751N01SXB, ESV751N01SX*	M25 A	C25 A	25 A	4	10
	ESV112N01SXB, ESV112N01SX*	M32 A	C32 A	30A	4	10
240V 1- (2/PE)	ESV251N01SXB, ESV251N02SXB, ESV371N01SXB, ESV371N02YXB, ESV371N02SF*	M10 A	C10 A	10 A	1.5	14
	ESV751N01SXB, ESV751N02YXB, ESV751N02SF*	M16 A	C16 A	15 A	2.5	14
	ESV112N02YXB, ESV112N02SFC, ESV112N01SXB, ESV112N01SX*	M20 A	C20 A	20 A	2.5	12
	ESV152N02YXB, ESV152N02SF*	M25 A	C25 A	25 A	2.5	12
	ESV222N02YXB, ESV222N02SF*	M32 A	C32A	30 A	4	10
240V 3- (3/PE)	ESV371N02YXB, ESV751N02YXB, ESV371N02Y_* , ESV751N02Y_*	M10 A	C10 A	10 A	1.5	14
	ESV112N02YXB, ESV152N02YXB, ESV112N02TXB, ESV152N02TXB, ESV112N02Y_* , ESV152N02Y_*	M16 A	C16 A	12 A	1.5	14
	ESV222N02YXB, ESV222N02TXB, ESV222N02YX*	M20 A	C20 A	20 A	2.5	12
	ESV402N02T_*	M32 A	C32 A	30 A	4.0	10
	ESV552N02T_--	M40 A	C40 A	35 A	6.0	8
	ESV752N02T_--	M50 A	C50 A	45 A	10	8
	ESV113N02TXB	M80 A	C80 A	80 A	16	6
	ESV153N02TXB	M100 A	C100 A	90 A	16	4



Type		Recommendations				
		Fuse	Miniature circuit breaker ⁽¹⁾	Fuse ⁽²⁾ or Breaker ⁽³⁾ (N. America)	Input Power Wiring (L1, L2, L3, PE)	
					[mm ²]	[AWG]
400V or 480V 3~(3/PE)	ESV371N04TXB ...ESV222N04TXB ESV371N04T_* ...ESV222N04T_* ESV371N04TF* ...ESV222N04TF*	M10 A	C10 A	10 A	1.5	14
	ESV302N04TX*	M16 A	C16 A	15 A	2.5	14
	ESV402N04T_*	M16 A	C16 A	20 A	2.5	14
	ESV552N04T_*	M20 A	C20 A	20 A	2.5	14
400V or 480V 3~(3/PE)	ESV752N04T_~	M25 A	C25 A	25 A	4.0	10
	ESV113N04TXB	M40 A	C40 A	40 A	4	8
	ESV153N04TXB	M50 A	C50 A	50 A	10	8
	ESV183N04TXB	M63 A	C63 A	70 A	10	6
600V 3~(3/PE)	ESV223N04TXB	M80 A	C80 A	80 A	16	6
	ESV751N06TXB ...ESV222N06TXB ESV751N06T_* ...ESV222N06T_* , ESV302N06T_*	M10 A	C10 A	10 A	1.5	14
	ESV402N06TXB, ESV402N06T_*	M16 A	C16 A	12 A	1.5	14
	ESV552N06TXB, ESV552N06T_*	M16 A	C16 A	15 A	2.5	14
	ESV752N06TXB, ESV752N06T_~	M20 A	C20 A	20 A	2.5	12
	ESV113N06TXB	M32 A	C32 A	30 A	4	10
	ESV153N06TXB	M40 A	C40 A	40 A	4	8
	ESV183N06TXB	M50 A	C50 A	50 A	6	8
ESV223N06TXB	M63 A	C63 A	60 A	10	8	

- (1) Installations with high fault current due to large supply mains may require a type D circuit breaker.
 (2) UL Class CC or T fast-acting current-limiting type fuses, 200,000 AIC, preferred. Bussman KTK-R, JJJ or JJS or equivalent.
 (3) Thermomagnetic type breakers preferred.

- ~ 11th digit of part number: F = Integral EMC Filter
 L = Integral EMC Filter and Integrated Line Disconnect (NEMA 4X/IP65 Models only)
 M = Integrated Line Disconnect (NEMA 4X/IP65 Models only)
 X = No EMC Filter/No Line Disconnect
 * = Last digit of part number: C = N4X Indoor only (convection cooled)
 E = N4X Indoor/Outdoor (convection cooled)
 ~ = Last digit of part number: D = N4X Indoor only (fan cooled)
 F = N4X Indoor/Outdoor (fan cooled)

Observe the following when using Ground Fault Circuit Interrupters (GFCIs):

- Installation of GFCI only between supplying mains and controller.
- The GFCI can be activated by:
 - capacitive leakage currents between the cable screens during operation (especially with long, screened motor cables)
 - connecting several controllers to the mains at the same time
 - RFI filters

3.2.3 Control Terminals

Control Terminal Strip for 0.33 - 10 HP (0.25 - 7.5 kW):

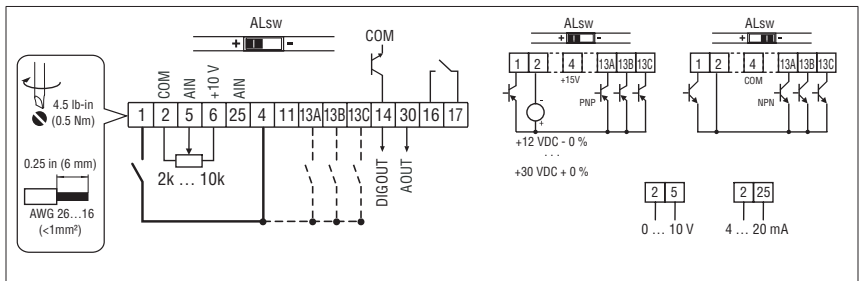



Installation

Control Terminal Strip for 15HP (11 kW) and Greater Drives:

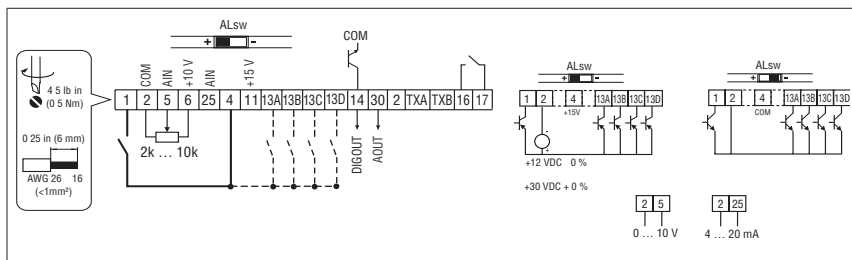

NOTE

Control and communications terminals provide basic insulation when the drive is connected to a power system rated up to 300V between phase to ground (PE) and the applied voltage on terminals 16 and 17 is less than 250 VAC between phase phase and ground (PE).

Terminal	Description	Important
1	Digital Input: Start/Stop	input resistance = 4.3kΩ
2	Analog Common	
5	Analog Input: 0...10 VDC	input resistance: >50 kΩ
6	Internal DC supply for speed pot	+10 VDC, max. 10 mA
25	Analog Input: 4...20 mA	input resistance: 250Ω
4	Digital Reference/Common	+15 VDC / 0 VDC, depending on assertion level
11	Internal DC supply for external devices	+12 VDC, max. 50 mA
13A	Digital Input: Configurable with P121	input resistance = 4.3kΩ
13B	Digital Input: Configurable with P122	
13C	Digital Input: Configurable with P123	
13D*	Digital Input: Configurable with P124	
14	Digital Output: Configurable with P142, P144	DC 24 V / 50 mA; NPN
30	Analog Output: Configurable with P150...P155	0...10 VDC, max. 20 mA
2*	Analog Common	
TXA*	RS485 TxA	
TXB*	RS485 TxB	
16	Relay output: Configurable with P140, P144	AC 250 V / 3 A
17		DC 24 V / 2 A ... 240 V / 0.22 A, non-inductive

* = Terminal is part of the terminal strip for the 15-30HP (11-22 kW) Models only.

Assertion level of digital inputs

The digital inputs can be configured for active-high or active-low by setting the Assertion Level Switch (ALsw) and P120. If wiring to the drive inputs with dry contacts or with PNP solid state switches, set the switch and P120 to "High" (+). If using NPN devices for inputs, set both to "Low" (-). Active-high (+) is the default setting.

HIGH = +12 ... +30 V

LOW = 0 ... +3 V



NOTE

An **F_{RL}** fault will occur if the Assertion Level switch (ALsw) position does not match the parameter P120 setting and P100 or any of the digital inputs (P121...P124) is set to a value other than 0.



4 Commissioning

4.1 Local Keypad & Display

SMV Models: 0.33-10 HP (0.25-7.5 kW)	SMV Models: 15HP (11 kW) and greater
4-Character Display	4-Character plus CTRL Display

Display	START BUTTON
	In Local Mode (P100 = 0, 4, 6), this button will start the drive.
	STOP BUTTON
	Stops the drive, regardless of which mode the drive is in.
	WARNING! When JOG is active, the STOP button will not stop the drive!
	ROTATION
	In Local Mode (P100 = 0, 4, 6), this selects the motor rotation direction: <ul style="list-style-type: none"> - The LED for the present rotation direction (FWD or REV) will be on - Press R/F; the LED for the opposite rotation direction will blink - Press M within 4 seconds to confirm the change - The blinking direction LED will turn on, and the other LED will turn off When rotation direction is changed while the drive is running, the commanded direction LED will blink until the drive is controlling the motor in the selected direction.
	MODE
	Used to enter/exit the Parameter Menu when programming the drive and to enter a changed parameter value.
	UP AND DOWN BUTTONS
	Used for programming and can also be used as a reference for speed, PID setpoint, or torque setpoint.
	When the ▲ and ▼ buttons are the active reference, the middle LED on the left side of the display will be on.



Commissioning

Display	INDICATING LEDs (on 4-character display)		
	FWD LED: Indicate the present rotation direction is forward. Refer to ROTATION description above.		
	REV LED: Indicate the present rotation direction is reverse. Refer to ROTATION description above.		
	AUTO LED: Indicates that the drive has been put into Auto mode from one of the TB13 inputs (P121...P124 set to 1...7). Also indicates that PID mode is active (if enabled).		
	RUN LED: Indicates that the drive is running.		
	▲ ▼ LED: Indicates that the ▲ ▼ are the active reference.		
	NOTE If the keypad is selected as the auto reference (P121...P124 is 6) and the corresponding TB-13 input is closed, the AUTO LED and ▲ ▼ LEDs will both be on.		
FUNCTIONS THAT FOLLOW ARE APPLICABLE TO SMV DRIVES 15HP (11kW) AND GREATER			
	CTRL The CTRL pushbutton selects the start and speed reference control sources for the drive. Press mode button to accept the new control mode selection.		
CTRL LEDs	START CONTROL	REFERENCE CONTROL	
	[LOCAL] [MAN]	Keypad	P101 Settings
	[LOCAL] [AUTO]	Keypad	Terminal 13x Settings
	[REMOTE] [MAN]	Terminal Strip	P101 Settings
	[REMOTE] [AUTO]	Terminal Strip	Terminal 13x Settings
If P100 = 6 the CTRL button is used to toggle start control between the terminal strip [REMOTE] and the keypad [LOCAL]		<ul style="list-style-type: none"> - REM/LOC LED indicating the present start control source is ON - Press [CTRL]; the LED for other start control source will blink - Press [M] within 4 sec to confirm the change - Blinking LED will turn ON (the other LED will turn OFF) 	
If P113 = 1 the CTRL button is used to toggle reference control between the TB-13x setup [AUTO] and P101 [MANUAL]		<ul style="list-style-type: none"> - AUT/MAN LED indicating present reference control is ON - Press [CTRL]; the other reference control will blink - Press [M] within 4 sec to confirm change - Blinking LED will turn ON (the other LED will turn OFF) 	
If P100 = 6 and P113 = 1, it is possible to change the start and reference control sources at the same time			



Display	START CONTROL		
	The REMOTE/LOCAL LEDs indicate the current start control source. If the start control source is a remote keypad or the network, then both LEDs will be OFF.		
	REFERENCE CONTROL		
	The AUTO/MANUAL LEDs indicate the current reference control source.		
	If P113 = 0 or 2, the AUTO/MANUAL LEDs will match the AUTO LED on the 4-character display. If P113 = 0 and no AUTO reference has been setup on the terminal strip, the MANUAL LED will turn ON and the AUTO LED will turn OFF.		
	If P113 = 1, the AUTO/MANUAL LEDs show the commanded reference control source as selected by the [CTRL] button. If the [CTRL] button is used to set the reference control source to AUTO but no AUTO reference has been setup on the terminal strip, reference control will follow P101 but the AUTO LED will remain ON.		
	UNITS LEDs		
	HZ: current display value is in Hz	In Speed mode, if P178 = 0 then HZ LED will be ON. If P178 > 0, the Units LEDs follow the setting of P177 when the drive is in run (non-programming) mode. In Torque mode, the HZ LED will be ON when the drive is in run (non-programming) mode.	
	%: current display value is in %		
	RPM: current display value is in RPM		
	AMPS: current display value is in Amps		
	/UNITS current display value is a per unit (i.e./sec, /min, /hr, etc.)		In Pid mode, the Units LEDs follow the setting of P203 when the drive is in run (non-programming) mode. If P179 > 0, the Units LEDs will show the unit of the diagnostic parameter that is being displayed.

4.2 Drive Display and Modes of Operation

Speed Mode Display

In the standard mode of operation, the drive frequency output is set directly by the selected reference (keypad, analog reference, etc.). In this mode, the drive display will show the drive's output frequency.

PID Mode Display

When the PID mode is enabled and active, the normal run display shows the actual PID setpoint. When PID mode is not active, the display returns to showing the drive's output frequency.

Torque Mode Display

When the drive is operating in Vector Torque mode, the normal run display shows the drive's output frequency.



Commissioning

4.3 Parameter Setting

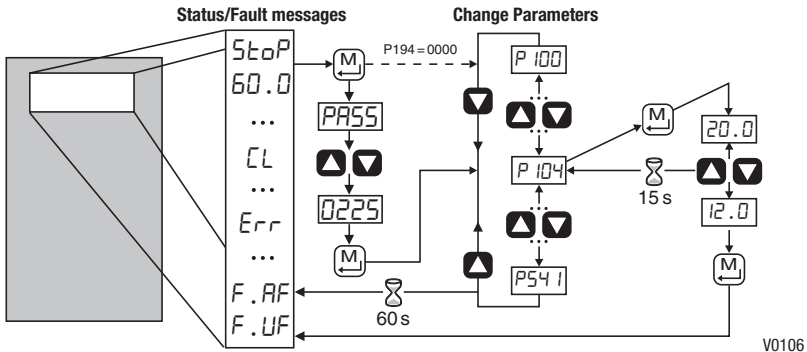

V0106

4.4 Electronic Programming Module (EPM)

The EPM contains the drives operational memory. Parameter settings are stored in the EPM and setting changes are made to the "User settings" in the EPM.

An optional EPM Programmer (model EEPM1RA) is available that allows:

- An EPM to be copied directly to another EPM.
- An EPM to be copied to the memory of the EPM Programmer.
- Stored files can be modified in the EPM Programmer.
- Stored files can be copied to another EPM.



EPM Module in SMV Drive

As the EPM Programmer is battery operated, parameter settings can be copied to an EPM and inserted into a drive without power being applied to the drive. This means that the drive will be fully operational with the new settings on the next application of power.

Additionally, when the drives parameter settings are burned into an EPM with the EPM Programmer, the settings are saved in two distinct locations; the "User settings" and the "OEM default settings". While the User settings can be modified in the drive, the OEM settings cannot. Thus, the drive can be reset not only to the "factory" drive default settings (shown in this manual), but can be set to the Original Machine settings as programmed by the OEM.

While the EPM can be removed for copying or to use in another drive, it must be installed for the drive to operate (a missing EPM will trigger an **F.F I** fault)







4.5 Parameter Menu

4.5.1 Basic Setup Parameters

Code		Possible Settings		IMPORTANT
No.	Name	Default	Selection	
P 100	Start Control Source	0	0 Local Keypad	Use RUN button on front of drive to start
			1 Terminal Strip	Use start/stop circuit wired into the terminal strip. Refer to section 3.2.3
			2 Remote Keypad Only	Use RUN button on optional Remote Keypad to start
			3 Network Only	<ul style="list-style-type: none"> Start command must come from network (Modbus, CANopen, etc) Requires optional communication module (refer to the network module documentation). Must also set one of the TB-13 inputs to 9 (Network Enable); see P121...P124
			4 Terminal Strip or Local Keypad	Allows start control to be switched between terminal strip and local keypad using one of the TB-13 inputs. See note below.
			5 Terminal Strip or Remote Keypad	Allows start control to be switched between terminal strip and optional remote keypad using one of the TB-13 inputs. See Note below
			6 CTRL button select	Allows start control to be switched between terminal strip and local keypad using the CTRL button. NOTE: P100 Selection 6 is applicable to SVM 15HP (11 kW) and greater models only.
		 NOTE <ul style="list-style-type: none"> P100 = 4, 5: To switch between control sources, one of the TB-13 inputs (P121...P124) must be set to 08 (Control Select); TB-13x OPEN (or not configured): Terminal strip control TB-13x CLOSED: Local (P100 = 4) or Remote (P100 = 5) keypad P100 = 0, 1, 4, 6: Network can take control if P121...P124 = 9 and the corresponding TB-13x input is CLOSED. The STOP button on the front of the drive is always active except in JOG mode. An F_{RL} fault will occur if the Assertion Level switch (ALSw) position does not match the P120 setting and P100 is set to a value other than 0. 		
P 101	Standard Reference Source	0	0 Keypad (Local or Remote)	Selects the default speed or torque reference when no Auto Reference is selected using the TB-13 inputs
			1 0-10 VDC	
			2 4-20 mA	
			3 Preset #1	
			4 Preset #2	
			5 Preset #3	
			6 Network	

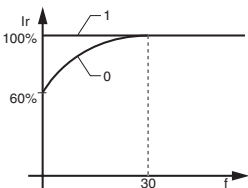

Commissioning

Code		Possible Settings				IMPORTANT
No.	Name	Default	Selection			
P 102	Minimum Frequency	0.0	0.0	{Hz}	P103	<ul style="list-style-type: none"> P102, P103 are active for all speed references When using an analog speed reference, also see P160, P161
P 103	Maximum Frequency	60.0	7.5	{Hz}	500	
		 NOTE <ul style="list-style-type: none"> P103 cannot be set below Minimum Frequency (P102) To set P103 above 120 Hz: <ul style="list-style-type: none"> Scroll up to 120 Hz; display shows H Fr (flashing). Release s button and wait one second Press s button again to continue increasing P103 				
 WARNING! Consult motor/machine manufacturer before operating above rated frequency. Overspeeding the motor/machine may cause damage to equipment and injury to personnel!						
P 104	Acceleration Time 1	20.0	0.0	{s}	3600	<ul style="list-style-type: none"> P104 = time of frequency change from 0 Hz to P167 (base frequency) P105 = time of frequency change from P167 to 0 Hz For S-ramp accel/decel, adjust P106
P 105	Deceleration Time 1	20.0	0.0	{s}	3600	
		 EXAMPLE: IF P103 = 120 Hz, P104 = 20.0 s and P167 (base frequency) = 60 Hz; then the rate of frequency change from 0 Hz to 120 Hz = 40.0 s				
P 106	S-Ramp Integration Time	0.0	0.0	{s}	50.0	<ul style="list-style-type: none"> P106 = 0.0: Linear accel/decel ramp P106 > 0.0: Adjusts S-ramp curve for smoother ramp
P 107 ⁽¹⁾	Line Voltage Selection	1*	0	Low (120, 200, 400, 480VAC)		* The default setting is 1 for all drives except when using "reset 50" (Parameter P199, selection 4) with 480V models. In this case, the default setting is 0.
			1	High (120, 240, 480, 600VAC)		
P 108	Motor Overload	100	30	{%}	100	P108 = $\frac{\text{motor current rating}}{\text{SMV output rating}} \times 100$ Example: if motor = 3amps and SMV = 4amps, then P108 = 75%
		 NOTE Do not set above rated motor current as listed on the motor dataplate. The motor thermal overload function of the SMV is UL approved as a motor protection device. If the line power is cycled, the motor thermal state is reset to cold state. Cycling power after an overload fault could result in significantly reducing the motor life.				
P 109	Motor Overload Type	0	0	Speed Compensation		
			1	No Speed Compensation		

(1) Any changes to this parameter will not take effect until the drive is stopped



Code		Possible Settings		IMPORTANT
No.	Name	Default	Selection	
P110	Start Method	0	0 Normal	<p>Drive will automatically start when power is applied.</p> <p>When start command is applied, drive will apply DC braking according to P174, P175 prior to starting the motor</p> <p>Drive will automatically restart after faults, or when power is applied.</p> <p>Combines settings 2 and 3</p> <ul style="list-style-type: none"> • Drive will automatically restart after faults, or when power is applied. • After 3 failed attempts, drive will Auto Restart with DC brake. • P110 = 5: Performs speed search, starting at Max Frequency (P103) • P110 = 6: Performs speed search, starting at the last output frequency prior to faulting or power loss • If P111 = 0, a flying START is performed when a start command is applied.
			1 Start on Power-up	
			2 Start with DC Brake	
			3 Auto Restart	
			4 Auto Restart with DC Brake	
			5 Flying Start/Restart #1	
			6 Flying Start/Restart #2	
		<p>NOTE</p> <ul style="list-style-type: none"> • P110 = 0, 2: Start command must be applied at least 2 seconds after power-up; F_{UF} fault will occur if start command is applied too soon. • P110 = 1, 3...6: For automatic start/restart, the start source must be the terminal strip and the start command must be present. • P110 = 2, 4...6: If P175=999.9, dc braking will be applied for 15s. • P110 = 3...6: Drive will attempt 5 restarts; if all restart attempts fail, drive displays LC (fault lockout) and requires manual reset. • P110 = 5, 6: If drive cannot catch the spinning motor, drive will trip into F_{rF} fault. 		
<p>WARNING! Automatic starting/restarting may cause damage to equipment and/or injury to personnel! Automatic starting/restarting should only be used on equipment that is inaccessible to personnel.</p>				
P111	Stop Method	0	0 Coast	<p>Drive's output will shut off immediately upon a stop command, allowing the motor to coast to a stop</p> <p>The drive's output will shut off and then the DC Brake will activate (refer to P174, P175)</p> <p>The drive will ramp the motor to a stop according to P105 or P126.</p> <p>The drive will ramp the motor to 0 Hz and then the DC Brake will activate (refer to P174, P175)</p>
			1 Coast with DC Brake	
			2 Ramp	
			3 Ramp with DC Brake	
P112	Rotation	0	0 Forward Only	If PID mode is enabled, reverse direction is disabled (except for Jog).
			1 Forward and Reverse	



Commissioning

Code		Possible Settings		IMPORTANT
No.	Name	Default	Selection	
P113	Auto/Manual Control	0	0 Terminal Strip Control	The reference is dictated by the settings and state of the TB-13x terminals. If no AUTO reference has been setup on the terminal strip then reference control is dictated by P101.
			1 Auto/Manual (CTRL button select)	Allows the reference to be switched between auto and manual using the CTRL pushbutton on the drive keypad. If the CTRL pushbutton has selected AUTO reference but no AUTO reference has been setup on the terminal strip, then reference control is dictated by P101.
			2 Manual Control Only	Reference is dictated by P101 regardless of any AUTO source that may be selected by the TB-13x terminals.
		 NOTE P113 is applicable to SMV 15HP (11kW) and greater models only.		



4.5.2 I/O Setup Parameters

Code		Possible Settings		IMPORTANT
No.	Name	Default	Selection	
P 120	Assertion Level	2	1 Low 2 High	P120 and the Assertion Level switch must both match the desired assertion level unless P100, P121...P124 are all set to 0. Otherwise an F.AL fault will occur.
P 121	TB-13A Input Function	0	0 None	Disables input
P 122	TB-13B Input Function		1 AUTO Reference: 0-10 VDC	For frequency mode, see P160...P161, For PID mode, see P204...P205, For vector torque mode, see P330
			2 AUTO Reference: 4-20 mA	
P 123	TB-13C Input Function		3 AUTO Reference: Preset	For frequency mode see P131...P137, For PID mode, see P231...P233, For torque mode see, P331...P333
			* 13D: 3 = Reserved	
P 124	TB-13D* Input Function		4 AUTO Reference: MOP Up	<ul style="list-style-type: none"> Normally open: Close input to increase or decrease speed, PID setpoint or torque setpoint. MOP Up is not active while in STOP
			5 AUTO Reference: MOP Down	
			6 AUTO Reference: Keypad	
			7 AUTO Reference: Network	
			8 Control Select	Use when P100 = 4, 5 to switch between terminal strip control and local or remote keypad control.
			9 Network Enable	Required to start the drive through the network.
			10 Reverse Rotation	Open = Forward Closed = Reverse
			11 Start Forward	Refer to Note for typical circuit
			12 Start Reverse	
			13 Run Forward	Refer to Note for typical circuit
14 Run Reverse				
15 Jog Forward	Jog Forward speed = P134			
16 Jog Reverse	Jog Reverse speed = P135 ⚠ Active even if P112 = 0			
17 Accel/Decel #2	Refer to P125, P126			
18 DC Brake	Refer to P174; close input to override P175			
19 Auxiliary Ramp to Stop	Normally closed: Opening input will ramp drive to STOP according to P127, even if P111 is set to Coast (0 or 1).			
20 Clear Fault	Close to reset fault			
21 External Fault F_EF	Normally closed circuit; open to trip			
22 Inverse External Fault F_EF	Normally open circuit; close to trip			

WARNING!
 Jog overrides all STOP commands! To stop the drive while in Jog mode, the Jog input must be deactivated or a fault condition induced.



Commissioning

Code		Possible Settings		IMPORTANT																																		
No.	Name	Default	Selection																																			
	NOTE	<ul style="list-style-type: none"> When input is activated, settings 1...7 override P101 When TB-13A...TB-13D are configured for Auto References other than MOP, TB-13D overrides TB-13C, TB-13C overrides TB-13B and TB-13B overrides TB-13A. Any other Auto Reference will have priority over MOP. Settings 10...14 are only valid in Terminal Strip mode (P100 = 1, 4, 5, 6) If Start/Run/Jog Forward and Start/Run/Jog Reverse are both activated, drive will STOP If Jog input is activated while the drive is running, the drive will enter Jog mode; when Jog input is deactivated, drive will STOP An F_{RL} fault will occur if the Assertion Level switch (ALSw) position does not match the P120 setting and any of the digital inputs (P121...P124) are set to a value other than 0. An F_{IL} fault will occur under the following conditions: <ul style="list-style-type: none"> TB-13A...TB-13D settings are duplicated (each setting, except 0 and 3, can only be used once) One input is set to "MOP Up" and another is not set to "MOP Down", or vice-versa. One input is set to 10 and another input is set to 11...14. One input is set to 11 or 12 and another input is set for 13 or 14. Typical control circuits are shown below: <ul style="list-style-type: none"> If any input is set to 10, 12 or 14, P112 must be set to 1 for Reverse action to function. 																																				
	<p>Run / Stop with Direction P121 = 10</p>	<p>Start Forward / Start Reverse P121 = 11, P122 = 12</p>	<p>Run Forward / Run Reverse P121 = 13, P122 = 14</p>																																			
P 125	Acceleration Time 2	20.0	0.0	{s}	3600	<ul style="list-style-type: none"> Selected using TB-13A...TB-13D (P121... P124 = 17) For S-ramp accel/decel, adjust P106 																																
P 126	Deceleration Time 2	20.0	0.0	{s}	3600																																	
P 127	Deceleration Time for Auxiliary Ramp to Stop	20.0	0.0	{s}	3600		<ul style="list-style-type: none"> Selected using TB-13A...TB-13D (P121... P124 = 19). For S-ramp accel/decel, adjust P106 Once executed, this ramp time has priority over P105 and P126. 																															
P 131	Preset Speed #1	0.0	0.0	{Hz}	500	<table border="1"> <thead> <tr> <th>PRESET SPEED</th> <th>13A</th> <th>13B</th> <th>13C</th> </tr> </thead> <tbody> <tr> <td>1</td> <td>X</td> <td>--</td> <td>--</td> </tr> <tr> <td>2</td> <td>--</td> <td>X</td> <td>--</td> </tr> <tr> <td>3</td> <td>--</td> <td>--</td> <td>X</td> </tr> <tr> <td>4</td> <td>X</td> <td>X</td> <td>--</td> </tr> <tr> <td>5</td> <td>X</td> <td>--</td> <td>X</td> </tr> <tr> <td>6</td> <td>--</td> <td>X</td> <td>X</td> </tr> <tr> <td>7</td> <td>X</td> <td>X</td> <td>X</td> </tr> </tbody> </table>	PRESET SPEED	13A	13B	13C	1	X	--	--	2	--	X	--	3	--	--	X	4	X	X	--	5	X	--	X	6	--	X	X	7	X	X	X
PRESET SPEED	13A	13B	13C																																			
1	X	--	--																																			
2	--	X	--																																			
3	--	--	X																																			
4	X	X	--																																			
5	X	--	X																																			
6	--	X	X																																			
7	X	X	X																																			
P 132	Preset Speed #2	0.0	0.0	{Hz}	500																																	
P 133	Preset Speed #3	0.0	0.0	{Hz}	500																																	
P 134	Preset Speed #4	0.0	0.0	{Hz}	500																																	
P 135	Preset Speed #5	0.0	0.0	{Hz}	500																																	
P 136	Preset Speed #6	0.0	0.0	{Hz}	500																																	
P 137	Preset Speed #7	0.0	0.0	{Hz}	500																																	



Code		Possible Settings		IMPORTANT
No.	Name	Default	Selection	
P 140	Relay Output TB-16, 17	0	0 None	Disables the output
			1 Run	Energizes when the drive is running
			2 Reverse	Energizes when reverse rotation is active
			3 Fault	De-energizes when the drive trips, or power is removed
			4 Inverse Fault	Energizes when the drive trips
			5 Fault Lockout	P110 = 3...6: De-energizes if all restart attempts fail
			6 At Speed	Energizes when output frequency = commanded frequency
			7 Above Preset Speed #6	Energizes when output frequency > P136
			8 Current Limit	Energizes when motor current = P171
			9 Follower Loss (4-20 mA)	Energizes when 4-20 mA signal falls below 2 mA
			10 Loss of Load	Energizes when motor load drops below P145; Refer to P146 also
			11 Local Keypad Control Active	
			12 Terminal Strip Control Active	
			13 Remote Keypad Control Active	Energizes when the selected source is active for start control
			14 Network Control Active	
			15 Standard Reference Active	Energizes when P101 reference is active
			16 Auto Reference Active	Energizes when Auto Reference is activated using TB-13 input; refer to P121...P124
			17 Sleep Mode Active	Refer to P240...P242
			18 PID Feedback < Min. Alarm	Energizes when PID feedback signal < P214
			19 Inverse PID Feedback < Min. Alarm	De-energizes when PID feedback signal < P214
			20 PID Feedback > Max Alarm	Energizes when PID feedback signal > P215
			21 Inverse PID Feedback > Max Alarm	De-energizes when PID feedback signal > P215
			22 PID Feedback within Min/Max Alarm range	Energizes when PID feedback signal is within the Min/Max Alarm range; refer to P214, P215
			23 PID Feedback outside Min/Max Alarm range	Energizes when PID feedback signal is outside the Min/Max Alarm range; refer to P214, P215
			24 Reserved	
25 Network Activated	Requires optional communication module (refer to the network module documentation).			
P 142	TB-14 Output	0	0...23 (same as P140)	
			24 Dynamic Braking	For use with Dynamic Braking option
			25 Network Activated	Requires optional communication module (refer to the network module documentation).



Commissioning

Code		Possible Settings				IMPORTANT																	
No.	Name	Default	Selection																				
P 144	Digital Output Inversion		<table border="1"> <thead> <tr> <th>P144</th> <th>Invert P142</th> <th>Invert P140</th> </tr> </thead> <tbody> <tr> <td>0</td> <td>NO</td> <td>NO</td> </tr> <tr> <td>1</td> <td>NO</td> <td>YES</td> </tr> <tr> <td>2</td> <td>YES</td> <td>NO</td> </tr> <tr> <td>3</td> <td>YES</td> <td>YES</td> </tr> </tbody> </table>			P144	Invert P142	Invert P140	0	NO	NO	1	NO	YES	2	YES	NO	3	YES	YES	<p>Used to invert the selections for P140 (Relay Output) and P142 (TB-14 Output). EXAMPLE: When P140 = 6 (AT SPEED), the relay is energized when output frequency = commanded frequency. IF P144=1 or 3, then P140 is inverted (INVERSE AT SPEED) and the relay is energized when the output frequency does not equal the command frequency.</p>		
			P144	Invert P142	Invert P140																		
			0	NO	NO																		
1	NO	YES																					
2	YES	NO																					
3	YES	YES																					
<p>i NOTE Inverting P140 or P142 when the parameter is set to NONE (0) will result in the output being energized continuously.</p>																							
<p>i NOTE For SMVector drives rated at 0.33 to 10 HP (0.25 to 7.5 kW), P144 is only available with software versions 3.0 and higher (refer to P501).</p>																							
P 145	Loss of Load Threshold	0	0	{%}	200	P140, P142 = 10: Output will energize if motor load falls below the P145 value longer than the P146 time																	
P 146	Loss of Load Delay	0.0	0.0	{s}	240.0																		
P 150	TB-30 Output	0	0 None			2-10 VDC signal can be converted to 4-20 mA with a total circuit impedance of 500 Ω																	
			1 0-10 VDC Output Frequency																				
			2 2-10 VDC Output Frequency																				
			3 0-10 VDC Load																				
			4 2-10 VDC Load																				
			5 0-10 VDC Torque																				
			6 2-10 VDC Torque																				
			7 0-10 VDC Power (kW)																				
			8 2-10 VDC Power (kW)																				
			9 Network Controlled				Requires optional communication module (refer to the network module documentation).																
P 152	TB-30 Scaling: Frequency	60.0	3.0	{Hz}	2000	If P150 = 1 or 2, sets the frequency at which output equals 10 VDC																	
P 153	TB-30 Scaling: Load	200	10	{%}	500	If P150 = 3 or 4, sets the Load (as a percent of drive current rating) at which output equals 10 VDC.																	
P 154	TB-30 Scaling: Torque	100	10	{%}	1000	If P150 = 5 or 6, sets the Torque (as a percent of motor rated torque) at which output equals 10 VDC																	
P 155	TB-30 Scaling: Power (kW)	1.0	0.1	{kW}	200.0	If P150 = 7 or 8, sets the power at which output equals 10 VDC																	



4.5.3 Advanced Setup Parameters

Code		Possible Settings			IMPORTANT	
No.	Name	Default	Selection			
P 160	Speed at Minimum Signal	0.0	-999.0	{Hz}	1000	<p style="text-align: right;">V0111</p>
P 161	Speed at Maximum Signal	60.0	-999.0	{Hz}	1000	
		<div style="display: flex; align-items: center;"> <div style="border: 1px solid black; padding: 2px; margin-right: 5px;">i</div> <div> <p>NOTE</p> <ul style="list-style-type: none"> • P160 sets the output frequency at 0% analog input • P161 sets the output frequency at 100% analog input • P160 or P161 < 0.0 Hz: For scaling purposes only; does not indicate opposite direction! • P160 > P161: Drive will react inversely to analog input signal </div> </div>				
P 162	Analog Input Filter	0.01	0.00	{s}	10.00	Adjusts the filter on the analog inputs (TB-5 and TB-25) to reduce the effect of signal noise
P 163	TB-25 Loss Action	0	0 No Action 1 Fault F _{oL} 2 Go to Preset when TB-25 is: Speed reference: P137 PID feedback source: P137 PID setpoint reference: P233 Torque reference: P333			<ul style="list-style-type: none"> • Selects the reaction to a loss of the 4-20 mA signal at TB-25. • Signal is considered lost if it falls below 2 mA • Digital outputs can also indicate a loss of 4-20 mA signal; see P140, P142
P 165	Carrier Frequency	See Notes	0 4 kHz 1 6 kHz 2 8 kHz 3 10 kHz			<ul style="list-style-type: none"> • As carrier frequency is increased, motor noise is decreased • Observe derating in section 2.3 • Automatic shift to 4 kHz at 120% load • NEMA 4X (IP65) Models: Default = 0 (4kHz) • NEMA 1 (IP31) Models: Default = 1 (6kHz)
P 167 ⁽¹⁾	Base Frequency	60.0	25.0	{Hz}	1500	<p style="text-align: right;">V0112</p>
P 168	Fixed Boost		0.0	{%}	30.0	
		<div style="display: flex; align-items: center;"> <div style="border: 1px solid black; padding: 2px; margin-right: 5px;">i</div> <div> <p>NOTE</p> <ul style="list-style-type: none"> • P167 = rated motor frequency for standard applications • P168 = default setting depends on drive rating </div> </div>				
P 169	Accel Boost	0.0	0.0	{%}	20.0	Accel Boost is only active during acceleration
P 170	Slip Compensation	0.0	0.0	{%}	10.0	Increase P170 until the motor speed no longer changes between no load and full load conditions.

(1) Any changes to this parameter will not take effect until the drive is stopped



Commissioning

Code		Possible Settings			IMPORTANT	
No.	Name	Default	Selection			
P 171 ⁽¹⁾	Current Limit	Max I	30	{%}	Max I	<ul style="list-style-type: none"> When the limit is reached, the drive displays CL (Current Limit), and either the acceleration time increases or the output frequency decreases. Digital outputs can also indicate when the limit is reached; see P140, P142. Refer to section 2.3 for the maximum output current Max I (%)
P 174	DC Brake Voltage	0.0	0.0	{%}	30.0	Setting is a percent of the nominal DC bus voltage.
P 175	DC Brake Time	0.0	0.0	{s}	999.9	<p>NOTE CONFIRM MOTOR SUITABILITY FOR USE WITH DC BRAKING</p> <p>DC Brake voltage (P174) is applied for the time specified by P175 with the following exceptions:</p> <ul style="list-style-type: none"> If P111=1, 3 and P175=999.9 the brake voltage will be applied continuously until a run or fault condition occurs. If P110=2, 4...6 and P175=999.9, brake voltage will be applied for 15s If P121...P124=18 and the corresponding TB-13 input is CLOSED, brake voltage will be applied until the TB-13 input is OPENED or a fault condition occurs.
P 177	Speed Units	0	0	Hz	Select the UNITS LED that will be illuminated when the drive is running in speed control mode. For this parameter to be used, P178 must be set to a value other than 0. IF P178 is set to 0, the HZ LED will be illuminated regardless of the value set in P177.	
			1	RPM		
2	%					
3	/UNITS					
4	NONE					
	<p>NOTE: P177 is applicable to SMV 15HP (11kW) and greater models only.</p>					
P 178	Display Frequency Multiplier	0.00	0.00	650.00	<ul style="list-style-type: none"> Allows frequency display to be scaled P178 = 0.00: Scaling disabled P178 > 0.00: Display = Actual Frequency X P178 	
				<p>EXAMPLE If P178 = 29.17 and actual frequency = 60 Hz, then Drive displays 1750 (rpm)</p>		
P 179	Run Screen Display	0	0	{Parameter Number}	599	<ul style="list-style-type: none"> 0 = Normal Run Screen, this display depends on mode of operation. Refer to section 4.2. Other selections choose a diagnostic parameter to display (P501...P599).

(1) Any changes to this parameter will not take effect until the drive is stopped





Code		Possible Settings			IMPORTANT
No.	Name	Default	Selection		
P 181	Skip frequency 1	0.0	0.0	{Hz} 500	<ul style="list-style-type: none"> Drive will not run in the defined skip range; used to skip over frequencies that cause mechanical vibration P181 and P182 define the start of the skip ranges P184 > 0 defines the bandwidth of both ranges.
P 182	Skip frequency 2	0.0	0.0	{Hz} 500	
P 184	Skip frequency bandwidth	0.0	0.0	{Hz} 10.0	
			NOTE Bandwidth (Hz) = f_s (Hz) + P184 (Hz) f_s = P181 or P182 EXAMPLE: P181 = 18 Hz and P184 = 4 Hz; skip range is from 18 to 22 Hz		
P 194	Password	225	0000	9999	<ul style="list-style-type: none"> Must enter password to access parameters P194 = 0000: Disables password
P 197	Clear Fault History	0	0 No Action	1 Clear Fault History	
P 199	Program Selection		0 Operate from User settings		
			1 Operate from OEM settings		Refer to Notes 1, 2 and 3
			2 Reset to OEM default settings		Refer to Note 1
			3 Reset to 60 Hz default settings		<ul style="list-style-type: none"> Refer to Note 4 Parameters are reset to the defaults listed in this manual. For P199=4, the following exceptions apply: <ul style="list-style-type: none"> - P103, P152, P161, P167 = 50.0 Hz - P304 = 50 Hz; - P305 = 1450 RPM - P107 = 0 (480 V drives only)
			4 Reset to 50 Hz default settings		
			5 Translate		Refer to Note 5
			WARNING! Modification of P199 can affect drive functionality! STOP and EXTERNAL FAULT circuitry may be disabled! Check P100 and P121...P124		
			NOTE 1 If the EPM does not contain valid OEM settings, a flashing ζF will be displayed when P199 is set to 1 or 2. NOTE 2 When P199 is set to 1, the drive operates from the OEM settings stored in the EPM Module and no other parameters can be changed (ζE will be displayed if attempted). NOTE 3 Auto Calibration is not possible when operating from OEM Settings. NOTE 4 Reset 60 and Reset 50 will set the Assertion Level (P120) to "2" (High). P120 may need to be reset for the digital input devices being used. An F_AL fault may occur if P120 and the Assertion switch are not set identically. NOTE 5 If an EPM that contains data from a previous compatible software version is installed: <ul style="list-style-type: none"> The drive will operate according to the previous data, but parameters cannot be changed (ζE will be displayed if attempted) To update the EPM to the current software version, set P199 = 5. The parameters can now be changed but the EPM is incompatible with previous software revisions. 		



Commissioning

4.5.4 PID Parameters

Code		Possible Settings			IMPORTANT	
No.	Name	Default	Selection			
P200	PID Mode	0	0	Disabled	<ul style="list-style-type: none"> Normal-acting: As feedback increases, motor speed decreases Reverse-acting: As feedback increases, motor speed increases PID mode is disabled in Vector Torque mode (P300 = 5) 	
			1	Normal-acting		
			2	Reverse-acting		
			 NOTE To activate PID mode, one of the TB-13 inputs (P121...P124) must be used to select the Auto Reference that matches the desired PID setpoint reference. If the selected PID setpoint reference uses the same analog signal as the PID feedback (P201), an F.L.L. fault will occur. Example: The desired PID setpoint reference is the keypad (▲ and ▼). Set TB-13x = 6 (Auto Reference: Keypad): <ul style="list-style-type: none"> TB-13x = closed: PID mode is active TB-13x = open: PID mode is disabled and the drive speed will be controlled by the reference selected in P101. 			
P201	PID Feedback Source	0	0	4-20 mA (TB-25)	Must be set to match the PID feedback signal	
			1	0-10 VDC (TB-5)		
P202	PID Decimal Point	1	0	PID Display = XXXX	Applies to P204, P205, P214, P215, P231... P233, P242, P522, P523	
			1	PID Display = XXX.X		
			2	PID Display = XX.XX		
			3	PID Display = X.XXX		
			4	PID Display = .XXXX		
P203	PID Units	0	0	%	Select the UNITS LED that will be illuminated when the drive is running in PID control mode	
			1	/UNITS		
			2	AMPS		
			3	NONE		
			 NOTE: P203 is applicable to SMV 15HP (11kW) and greater models only.			
P204	Feedback at Minimum Signal	0.0	-99.9	3100.0	Set to match the range of the feedback signal being used	
P205	Feedback at Maximum Signal	100.0	-99.9	3100.0	Example: Feedback signal is 0 - 300 PSI; P204 = 0.0, P205 = 300.0	
P207	Proportional Gain	5.0	0.0	{%}	100.0	Used to tune the PID loop:
P208	Integral Gain	0.0	0.0	{s}	20.0	<ul style="list-style-type: none"> Increase P207 until system becomes unstable, then decrease P207 by 10-15%
P209	Derivative Gain	0.0	0.0	{s}	20.0	<ul style="list-style-type: none"> Next, increase P208 until feedback matches setpoint If required, increase P209 to compensate for sudden changes in feedback
						 NOTE <ul style="list-style-type: none"> Derivative Gain is very sensitive to noise on the feedback signal and must be used with care Derivative Gain is not normally required in pump and fan applications





Code		Possible Settings			IMPORTANT	
No.	Name	Default	Selection			
P210	PID Setpoint Ramp	20.0	0.0	{s}	100.0	<ul style="list-style-type: none"> time of setpoint change from P204 to P205 or vice versa. Used to smooth the transition from one PID setpoint to another, such as when using the Preset PID Setpoints (P231...P233)
P214	Minimum Alarm	0.0	P204		P205	Use with P140, P142 = 18...23
P215	Maximum Alarm	0.0	P204		P205	
P231	Preset PID Setpoint #1	0.0	P204		P205	TB-13A activated; P121 = 3 and P200 = 1 or 2
P232	Preset PID Setpoint #2	0.0	P204		P205	TB-13B activated; P122 = 3 and P200 = 1 or 2
P233	Preset PID Setpoint #3	0.0	P204		P205	TB-13C activated; P123 = 3 and P200 = 1 or 2
P240	Sleep Threshold	0.0	0.0	{Hz}	500.0	<ul style="list-style-type: none"> If drive speed < P240 for longer than P241, output frequency = 0.0 Hz; drive display = 5LP P240 = 0.0: Sleep mode is disabled. P200 = 0...2: Drive will start again when speed command is above P240 P242 > 0.0: Drive will restart when the PID feedback differs from the setpoint by more than the value of P242 or when the PID loop requires a speed above P240.
P241	Sleep Delay	30.0	0.0	{s}	300.0	
P242	Sleep Bandwidth	0.0	0.0		B_{max}	
			Where: $B_{max} = (P205 - P204) $			



Commissioning

4.5.5 Vector Parameters

Code		Possible Settings			IMPORTANT	
No.	Name	Default	Selection			
P300 ⁽¹⁾	Drive Mode	0	0	Constant V/Hz	Constant torque V/Hz control for general applications	
			1	Variable V/Hz	Variable torque V/Hz control for centrifugal pump and fan applications	
			2	Enhanced Constant V/Hz	For single or multiple motor applications that require better performance than settings 0 or 1, but cannot use Vector mode, due to:	
			3	Enhanced Variable V/Hz	<ul style="list-style-type: none"> Missing required motor data Vector mode causing unstable motor operation 	
			4	Vector Speed	For single-motor applications requiring higher starting torque and speed regulation	
			5	Vector Torque	For single-motor applications requiring torque control independent of speed	
			NOTE To configure the drive for either Vector mode or Enhanced V/Hz mode: <ul style="list-style-type: none"> P300 = 4, 5: <ul style="list-style-type: none"> Set P302...P306 according to motor nameplate Set P399 = 1 Make sure motor is cold (20° - 25° C) and apply a Start command Display will indicate CL for about 40 seconds Once the calibration is complete, the display will indicate StoP; apply another Start command to actually start the motor If an attempt is made to start the drive in Vector or Enhanced V/Hz mode before performing the Motor Calibration, the drive will display F_n Id and will not operate P300 = 2, 3: Same as above but only need to set P302...P304 			
P302 ⁽¹⁾	Motor Rated Voltage		0	{V}	600	<ul style="list-style-type: none"> Default setting = drive rating Set to motor nameplate data
P303 ⁽¹⁾	Motor Rated Current		0.0	{A}	500.0	
P304 ⁽¹⁾	Motor Rated Frequency	60	0	{Hz}	1000	Set to motor nameplate data
P305 ⁽¹⁾	Motor Rated Speed	1750	300	{RPM}	65000	
P306 ⁽¹⁾	Motor Cosine Phi	0.80	0.40		0.99	
				NOTE If motor cosine phi is not known, use one of the following formulas: $\cos \phi = \text{motor Watts} / (\text{motor efficiency} \times P302 \times P303 \times 1.732)$ $\cos \phi = \cos [\sin^{-1} (\text{magnetizing current} / \text{motor current})]$		
P310 ⁽¹⁾	Motor Stator Resistance	0.00	0.00	{Ω}	64.00	<ul style="list-style-type: none"> Will be automatically programmed by P399 Changing these settings can adversely affect performance. Contact factory technical support prior to changing
P311 ⁽¹⁾	Motor Stator Inductance	0.0	0.0	{mH}	2000	
P330	Torque Limit	100	0	{%}	400	When P300 = 5, sets the maximum output torque.

(1) Any changes to this parameter will not take effect until the drive is stopped



Code		Possible Settings				IMPORTANT
No.	Name	Default	Selection			
P331	Preset Torque Setpoint #1	100	0	{%}	400	TB-13A activated; P121 = 3 and P300 = 5
P332	Preset Torque Setpoint #2	100	0	{%}	400	TB-13B activated; P122 = 3 and P300 = 5
P333	Preset Torque Setpoint #3	100	0	{%}	400	TB-13C activated; P123 = 3 and P300 = 5
P340 ⁽¹⁾	Current Loop P Gain	0.25	0.00			Changing these settings can adversely affect performance. Contact factory technical support prior to changing.
P341 ⁽¹⁾	Current Loop I Gain	65	12	{ms}	9990	
P342 ⁽¹⁾	Speed Loop Adjust	0.0	0.0	{%}	20.0	
P399	Motor Auto-calibration	0	0 Calibration Not Done			<ul style="list-style-type: none"> • If P300 = 2...5, motor calibration must be performed, but motor data must be programmed first • An alternating CAL / Err will occur if: <ul style="list-style-type: none"> - motor calibration is attempted with P300 = 0 or 1 - motor calibration is attempted before programming motor data
			1 Calibration Enabled			
			2 Calibration Complete			
		 NOTE: To run the Auto Calibration: <ul style="list-style-type: none"> - Set P302...P306 according to motor nameplate - Set P399 = 1 - Make sure motor is cold (20° - 25° C) - Apply a Start command - Display will indicate CAL for about 40 seconds - Once the calibration is complete, the display will indicate Stop; apply another Start command to actually start the motor - Parameter P399 will now be set to 2. 				

(1) Any changes to this parameter will not take effect until the drive is stopped.

4.5.6 Network Parameters

Code		Possible Settings				IMPORTANT	
No.	Name	Default	Selection				
P400	Network Protocol		0	Not Active			This parameter setting is based upon the network or I/O module that is installed.
			1	Remote Keypad			
			2	Modbus RTU			
			3	CANopen			
			4	DeviceNet			
			5	Ethernet			
			6	Profibus			
			7	Lecorn-B			
			8	I/O Module			
P401 ... P499		Module Specific Parameters				Refer to the Communications Reference Guide specific to the network or I/O module installed.	



Commissioning

4.5.7 Diagnostic Parameters

Code		Display Range (READ ONLY)		IMPORTANT
No.	Name			
P500	Fault History			<ul style="list-style-type: none"> Displays the last 8 faults Format: n.xxx where: n = 1..8; 1 is the newest fault xxx = fault message (without the F.) Refer to section 5.3
P501	Software Version			Format: x.yz
P502	Drive ID			A flashing display indicates that the Drive ID stored in the EPM does not match the drive model it is plugged into.
P503	Internal Code			Alternating Display: xxx-; -yy
P505	DC Bus Voltage	0	{VDC} 1500	
P506	Motor Voltage	0	{VAC} 1000	
P507	Load	0	{%} 255	Motor load as % of drive's output current rating. Refer to section 2.3.
P508	Motor Current	0.0	{A} 1000	Actual motor current
P509	Torque	0	{%} 500	Torque as % of motor rated torque (vector mode only)
P510	kW	0.00	{kW} 650.0	
P511	kWh	0.0	{kWh} 9999999	Alternating display: xxx-; yyyy when value exceeds 9999
P512	Heatsink Temp	0	{°C} 150	Heatsink temperature
P520	0-10 VDC Input	0.0	{VDC} 10.0	Actual value of signal at TB-5
P521	4-20 mA Input	0.0	{mA} 20.0	Actual value of signal at TB-25
P522	TB-5 Feedback	P204	P205	TB-5 signal value scaled to PID feedback units
P523	TB-25 Feedback	P204	P205	TB-25 signal value scaled to PID feedback units
P525	Analog Output	0	{VDC} 10.0	Refer to P150...P155
P527	Actual Output Frequency	0	{Hz} 500.0	
P528	Network Speed Command	0	{Hz} 500.0	Command speed if (Auto: Network) is selected as the speed source
P530	Terminal and Protection Status			Indicates terminal status using segments of the LED display. (Refer to section 4.5.7.1)
P531	Keypad Status			Indicates keypad button status using segments of the LED display. (Refer to section 4.5.7.2)
P540	Total Run Time	0	{h} 9999999	Alternating display: xxx-; yyyy when value exceeds 9999
P541	Total Power On Time	0	{h} 9999999	



4.5.7.1 Terminal & Protection Status Display

Parameter P530 allows monitoring of the control terminal points and common drive conditions:

An illuminated LED segment indicates:

- the protective circuit is active (LED 1)
- the Logic Assertion Switch is set to High (+)
- input terminal is asserted (LED 2)
- output terminal is energized (LED 4)
- the Charge Relay is not a terminal, this segment will be illuminated when the Charge Relay is energized (LED 4).

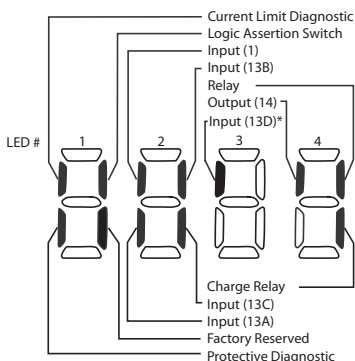

* Input 13D available on 15-30HP (11-22kW) models only

4.5.7.2 Keypad Status Display

Parameter P531 allows monitoring of the keypad pushbuttons:

An illuminated LED segment indicates when the button is depressed.

LED 1 and LED 2 are used to indicate pushbutton presses on a remote keypad that is attached to the drive. LED 3 and LED 4 indicate button presses on the local drive keypad.

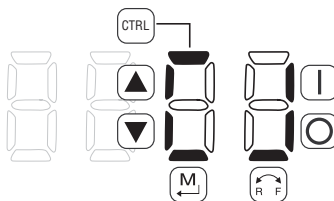

4.5.8 Onboard Communications Parameters 15-30HP (11-22kW)

The P6xx Onboard Communication parameters are applicable to the 15HP (11kW) and greater models only.

Code		Possible Settings		IMPORTANT
No.	Name	Default	Selection	
P600	Network Enable	0	0 Disabled	This parameter enables the onboard network communications.
			1 Remote Keypad	
			2 Modbus	
			7 Lecom	
			NOTE: Onboard Communications will be disabled if: - P600 = 0, or - P600 = 1 and P400 = 1, or - P600 = 2 and P400 = 2, 3, 4, 5, 6 or 7 - P600 = 7 and P400 = 2, 3, 4, 5, 6 or 7 If the onboard communications are disabled, the user will not have access to any of the other P6xx parameters.	
P610	Network Address	1	1 - 247	Modbus
		1	1 - 99	Lecom



Commissioning

Code		Possible Settings		IMPORTANT	
No.	Name	Default	Selection		
P611	Network Baud Rate	2	0 2400 bps	Modbus	
			1 4800 bps		
			2 9600 bps		
			3 19200 bps		
		0	0 9600 bps		Lecom
			1 4800 bps		
			2 2400 bps		
			3 1200 bps		
P612	Network Data Format	0	0 8, N, 2	Modbus Only	
			1 8, N, 1		
			2 8, E, 1		
			3 8, 0, 1		
P620	Network Control Level	0	0 Monitor Only	Lecom Only	
			1 Parameter Programming		
			2 Programming and Setpoint Control		
			3 Full Control		
P624	Network Powerup Start Status	0	0 Quick Stop	Lecom Only	
			1 Controller Inhibit		
P625	Network Timeout	10.0	0.0 - 300.0 seconds	Modbus	
		50	0 - 65000 milliseconds	Lecom	
P626	Network Timeout Action	4	0 No action	Modbus	
			1 Stop (P111)		
			2 Quick Stop		
			3 Controller Inhibit		
		0	4 Trip Fault, F.nF1	Lecom	
			0 No action		
			1 Controller Inhibit		
			2 Quick Stop		
P627	Network Messages Received		Read-Only: 0 - 9999	Valid network messages received	
			NOTE: When the number of messages exceeds 9999, the counter resets and resumes counting from 0.		



5 Troubleshooting and Diagnostics

5.1 Status/Warning Messages

	Status / Warning	Cause	Remedy
br	DC-injection brake active	DC-injection brake activated <ul style="list-style-type: none"> activation of digital input (P121...P124 = 18) automatically (P110 = 2, 4...6) automatically (P111 = 1, 3) 	Deactivate DC-injection brake <ul style="list-style-type: none"> deactivate digital input automatically after P175 time has expired
bF	Drive ID warning	The Drive ID (P502) stored on the EPM does not match the drive model.	<ul style="list-style-type: none"> Verify motor data (P302...P306) and perform Auto Calibration. Set drive mode (P300) to 0 or 1 Reset the drive (P199 to 3 or 4) and reprogram.
CAL	Motor Auto-calibration is being performed	See P300, P399	
cE	An EPM that contains valid data from a previous software version has been installed	An attempt was made to change parameter settings	Parameter settings can only be changed after the EPM data is converted to the current version (P199 = 5)
CL	Current Limit (P171) reached	Motor overload	<ul style="list-style-type: none"> Increase P171 Verify drive/motor are proper size for application
dEC	Decel Override	The drive has stopped decelerating to avoid tripping into HF fault, due to excessive motor regen (2 sec max).	If drive trips into HF fault: <ul style="list-style-type: none"> Increase P105, P126 Install Dynamic Braking option
Err	Error	Invalid data was entered, or an invalid command was attempted	
FCL	Fast Current Limit	Overload	Verify drive/motor are proper size for application
FSt	Flying Restart Attempt after Fault	P110 = 5,6	
GE	OEM Settings Operation warning	An attempt was made to change parameter settings while the drive is operating in OEM Settings mode (P199 = 1)	In OEM Settings mode, making changes to parameters is not permitted
GF	OEM Defaults data warning	An attempt was made to use (or reset to) the OEM default settings (P199 = 1 or 2) using an EPM without valid OEM data.	Install an EPM containing valid OEM Defaults data
LC	Fault Lockout	The drive attempted 5 restarts after a fault but all attempts were unsuccessful (P110 = 3...6)	<ul style="list-style-type: none"> Drive requires manual reset Check Fault History (P500) and correct fault condition
PdEC	PID Deceleration Status	PID setpoint has finished its ramp but the drive is still decelerating to a stop.	
PI d	PID Mode Active	Drive has been put into PID Mode. Refer to P200.	



Troubleshooting and Diagnostics

Status / Warning		Cause	Remedy
5LP	Sleep Mode is active	Refer to P240...P242	
5P	Start Pending	The drive has tripped into a fault and will automatically restart (P110 = 3...6)	To disable Auto-Restart, set P110 = 0...2
5Pd	PID Mode disabled.	Drive has been taken out of PID Mode. Refer to P200.	
5toP	Output frequency = 0 Hz (outputs U, V, W inhibited)	Stop has been commanded from the keypad, terminal strip, or network	Apply Start command (Start Control source depends on P100)

5.2 Drive Configuration Messages

When the Mode button is pressed and held, the drive's display will provide a 4-digit code that indicates how the drive is configured. If the drive is in a Stop state when this is done, the display will also indicate which control source commanded the drive to Stop (the two displays will alternate every second).

Configuration Display			
Format = x.y.zz	x = Control Source: L = Local Keypad t = Terminal Strip r = Remote Keypad n = Network	y = Mode: 5 = Speed mode P = PID mode t = Vector Torque mode	zz = Reference: LP = Keypad ▲ ▼ EU = 0-10 VDC (TB-5) E I = 4-20 mA (TB-25) JG = Jog nt = Network OP = MOP P L...P1 = Preset 1...7
	Example: <ul style="list-style-type: none"> L_5_LP = Local Keypad Start control, Speed mode, Keypad speed reference t_P_EU = Terminal Strip Start control, PID mode, 0-10 VDC setpoint reference n_t_P2 = Network Start control, Vector Torque mode, Preset Torque #2 reference 		
Stop Source Display			
Format = x_5tP	L_5tP = Stop command came from Local Keypad t_5tP = Stop command came from Terminal Strip r_5tP = Stop command came from Remote Keypad n_5tP = Stop command came from Network		



5.3 Fault Messages

The messages below show how they will appear on the display when the drive trips. When looking at the Fault History (P500), the F_{-} will not appear in the fault message.

Fault		Cause	Remedy ⁽¹⁾
$F_{-}HF$	High Temperature fault	Drive is too hot inside	<ul style="list-style-type: none"> Reduce drive load Improve cooling
$F_{-}RL$	Assertion Level fault	<ul style="list-style-type: none"> Assertion Level switch is changed during operation P120 is changed during operation P100 or P121...P124 are set to a value other than 0 and P120 does not match the Assertion Level Switch. 	<ul style="list-style-type: none"> Make sure the Assertion Level switch and P120 are both set for the type of input devices being used, prior to setting P100 or P121...P124. Refer to 3.2.3 and P120.
$F_{-}bF$	Personality fault	Drive Hardware	<ul style="list-style-type: none"> Cycle Power
$F_{-}CF$	Control fault	An EPM has been installed that is either blank or corrupted	<ul style="list-style-type: none"> Power down and install EPM with valid data
$F_{-}cF$	Incompatible EPM fault	An EPM has been installed that contains data from an incompatible parameter version	<ul style="list-style-type: none"> Reset the drive back to defaults (P199 = 3, 4) and then re-program If problem persists, contact factory technical support
$F_{-}dbF$	Dynamic Braking fault	Dynamic braking resistors are overheating	<ul style="list-style-type: none"> Increase active decel time (P105, P126, P127). Check mains voltage and P107
$F_{-}EF$	External fault	<ul style="list-style-type: none"> P121...P124 = 21 and that digital input has been opened. P121...P124 = 22 and that digital input has been closed. 	<ul style="list-style-type: none"> Correct the external fault condition Make sure digital input is set properly for NC or NO circuit
$F_{-}F I$	EPM fault	EPM missing or defective	Power down and replace EPM
$F_{-}F2$... $F_{-}F I2$	Internal faults		Contact factory technical support
$F_{-}Fnr$	Control Configuration Fault	The drive is setup for REMOTE KEYPAD control (P100=2 or 5) but is not setup to communicate with a remote keypad	Set P400 = 1, or P600 = 1
		The drive is setup for NETWORK ONLY control (P100=3) but is not setup for network communications	Set P400 or P600 to a valid network communications protocol selection
$F_{-}FaL$	Loss of 4-20 mA signal fault	4-20 mA signal (at TB-25) is below 2 mA (P163 = 1)	Check signal/signal wire
$F_{-}GF$	OEM Defaults data fault	Drive is powered up with P199=1 and OEM settings in the EPM are not valid.	Install an EPM containing valid OEM Defaults data or change P199 to 0.
$F_{-}HF$	High DC Bus Voltage fault	<p>Mains voltage is too high</p> <p>Decel time is too short, or too much regen from motor</p>	<p>Check mains voltage and P107</p> <p>Increase active decel time (P105, P126, P127) or install Dynamic Braking option</p>

(1) The drive can only be restarted if the error message has been reset.



Troubleshooting and Diagnostics

Fault		Cause	Remedy ⁽¹⁾
F_ IL	Digital Input Configuration fault (P121... P124)	More than one digital input set for the same function	Each setting can only be used once (except settings 0 and 3)
		Only one digital input configured for MOP function (Up, Down)	One input must be set to MOP Up, another must be set to MOP Down
		PID mode is entered with setpoint reference and feedback source set to the same analog signal	Change PID setpoint reference (P121... P124) or feedback source (P201).
		One of the digital inputs (P121...P124) is set to 10 and another is set to 11...14.	Reconfigure digital inputs
		One of the digital inputs (P121...P124) is set to 11 or 12 and another is set to 13 or 14.	
		PID enabled in Vector Torque mode (P200 = 1 or 2 and P300 = 5)	PID cannot be used in Vector Torque mode
F_ JF	Remote keypad fault	Remote keypad disconnected	Check remote keypad connections
F_ LF	Low DC Bus Voltage fault	Mains voltage too low	Check mains voltage
F_ n Id	No Motor ID fault	An attempt was made to start the drive in Vector or Enhanced V/Hz mode prior to performing the Motor Auto-calibration	See P300...P399 for Drive Mode setup and calibration.
F_ n tF	Module communication fault	Communication failure between drive and Network Module.	Check module connections
F_ nF I *** F_ nF9	Network Faults	Refer to the module documentation for Causes and Remedies.	
F_ OF	Output fault: Transistor fault	Output short circuit	Check motor/motor cable
		Acceleration time too short	Increase P104, P125
		Severe motor overload, due to: <ul style="list-style-type: none"> Mechanical problem Drive/motor too small for application 	<ul style="list-style-type: none"> Check machine / system Verify drive/motor are proper size for application
		Boost values too high	Decrease P168, P169
		Excessive capacitive charging current of the motor cable	<ul style="list-style-type: none"> Use shorter motor cables with lower charging current Use low capacitance motor cables Install reactor between motor and drive.
		Failed output transistor	Contact factory technical support
F_ OF I	Output fault: Ground fault	Grounded motor phase	Check motor and motor cable
		Excessive capacitive charging current of the motor cable	Use shorter motor cables with lower charging current
F_ PF	Motor Overload fault	Excessive motor load for too long	<ul style="list-style-type: none"> Verify proper setting of P108 Verify drive and motor are proper size for application
F_ rF	Flying Restart fault	Controller was unable to synchronize with the motor during restart attempt; (P110 = 5 or 6)	Check motor / load

(1) The drive can only be restarted if the error message has been reset.



Fault		Cause	Remedy ⁽¹⁾
F_5F	Single-Phase fault	A mains phase has been lost	Check mains voltage
F_UF	Start fault	Start command was present when power was applied (P110 = 0 or 2).	<ul style="list-style-type: none">• Must wait at least 2 seconds after power-up to apply Start command• Consider alternate starting method (refer to P110).

(1) The drive can only be restarted if the error message has been reset.



Appendix A

A.1 Permissible Cable Lengths

The table herein lists the permissible cable lengths for use with an SMV inverter with an internal EMC filter.



NOTE

This table is intended as a reference guideline only; application results may vary. The values in this table are based on testing with commonly available low-capacitance shielded cable and commonly available AC induction motors. Testing is conducted at worst case speeds and loads.

Maximum Permissible Cable Lengths (Meters) for SMV Model with Internal EMC Filters									
Mains	Model	4 kHz Carrier (P166 = 0)		6 kHz Carrier (P166 = 1)		8 kHz Carrier (P166 = 2)		10 kHz Carrier (P166 = 3)	
		Class A	Class B	Class A	Class B	Class A	Class B	Class A	Class B
240 V, 1-phase (2/PE)	ESV251 $\phi\phi$ 2SF ϕ	38	12	35	10	33	5	30	N/A
	ESV371 $\phi\phi$ 2SF ϕ	38	12	35	10	33	5	30	N/A
	ESV751 $\phi\phi$ 2SF ϕ	38	12	35	10	33	5	30	N/A
	ESV112 $\phi\phi$ 2SF ϕ	38	12	35	10	33	5	30	N/A
	ESV152 $\phi\phi$ 2SF ϕ	38	12	35	10	33	5	30	N/A
	ESV222 $\phi\phi$ 2SF ϕ	38	12	35	10	33	5	30	N/A
400/480 V, 3-phase (3/PE)	ESV371 $\phi\phi$ 4TF ϕ	30	4	25	2	20	N/A	10	N/A
	ESV751 $\phi\phi$ 4TF ϕ	30	4	25	2	20	N/A	10	N/A
	ESV112 $\phi\phi$ 4TF ϕ	30	4	25	2	20	N/A	10	N/A
	ESV152 $\phi\phi$ 4TF ϕ	30	4	25	2	20	N/A	10	N/A
	ESV222 $\phi\phi$ 4TF ϕ	30	4	25	2	20	N/A	10	N/A
	ESV302 $\phi\phi$ 4TF ϕ	30	4	25	2	20	N/A	10	N/A
	ESV402 $\phi\phi$ 4TF ϕ	54	5	48	3	42	2	N/A	N/A
	ESV552 $\phi\phi$ 4TF ϕ	54	5	48	3	42	2	N/A	N/A
	ESV752 $\phi\phi$ 4TF ϕ	54	5	48	3	42	2	N/A	N/A

NOTE: The “ $\phi\phi$ ” and “ ϕ ” symbols are place holders in the Model part number that contain different information depending on the specific configuration of the model. Refer to the SMV Type Number Designation table in section 2.2 for more information.

Notes

AC Technology Corporation

630 Douglas Street • Uxbridge, MA 01569 • USA

Sales: 800 217-9100 • Service: 508 278-9100

www.lenze-actech.com

(SV01F)