

KOMPAKT OTK

Series Air Handling Units with C2 Control System
Electrical Installation and Operation Manual

Table of Contents

1. INSTALLATION MANUAL	4
1.1. Electric Power Supply Connection	4
1.2. External Elements Connection	5
1.3. Temperature Sensors Installation	7
1.4. Control Panel Installation Requirements	7
1.5. Control Panel Connection	7
2. OPERATION MANUAL	8
2.1. Unit Control	8
2.2. Switching on the Unit	9
2.3. Control Panel Indication	9
2.4. Unit Programmable Settings	10
2.5. Other Control Functions	13
2.6. Troubleshooting	13
Unit Functional Diagram	15
Specification	16
Wiring Diagrams	17

1. INSTALLATION MANUAL

Installation works can be performed only by the specialists that have required qualification. During installation following requirements must be fulfilled:

 It is recommended to lay control cables separately from power cables, or use shielded cables. In such case it is necessary to earth cable shielding!

1.1. Electric Power Supply Connection

If the air handling unit voltage is ~230V; 50 Hz it is necessary to install the socket with grounding of corresponding capacity. If the voltage is ~400V; 50 Hz, the cable of electrical power supply is connected to the power supply terminal blocks, which are located inside the unit. It is necessary to connect earthing! Types of cables of connection of electrical power supply are specified in 1.1 Table:

1.1 Table

Electrical Power Supply Cable Types

Diagram No.	Type of Air Handling Unit	Cable Type
1	OTK 1200PW; OTK 2000PW	3 x 1,5 mm ² (Cu)
2	OTK 700PE	5 x 2,5 mm ² (Cu)
	OTK 1200PE	5 x 4,0 mm ² (Cu)
3	OTK 2000PE	5 x 10,0 mm ² (Cu)

 Unit must be connected to the stationary installation by solid cable through circuit breaker with max. 30mA current leakage protection.

 Before connecting unit to the electrical power supply, it is necessary to check whether earthing has been installed properly.

1.2. External Elements Connection

All external control elements are connected to the board terminals (1.2 Picture), which are inside the unit control box.

External elements connection diagram is given in the 1.2a Picture.

1.2 Picture

Connection Board C2-P1

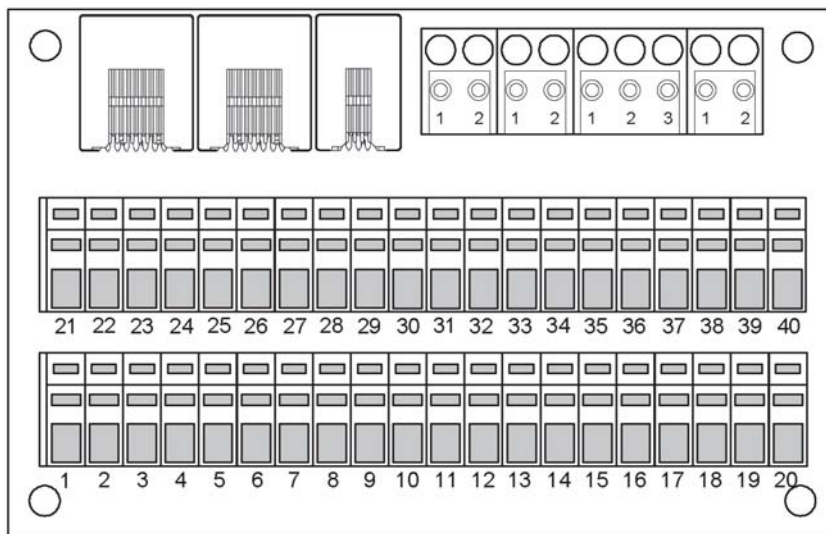



The air handling unit is equipped with season (WINTER / SUMMER) switch, located on the outside unit's wall near connection cables.

Applicability of the switch:

- In the air handling units with an electrical heater, during winter time heating function is switched on (position **I**) and during summertime for economy of the electric energy is switched off (position **0**).
- In the air handling units with hot water air heater, the circulation pump is switched on (position **I**) or during summertime switched off (position **0**).

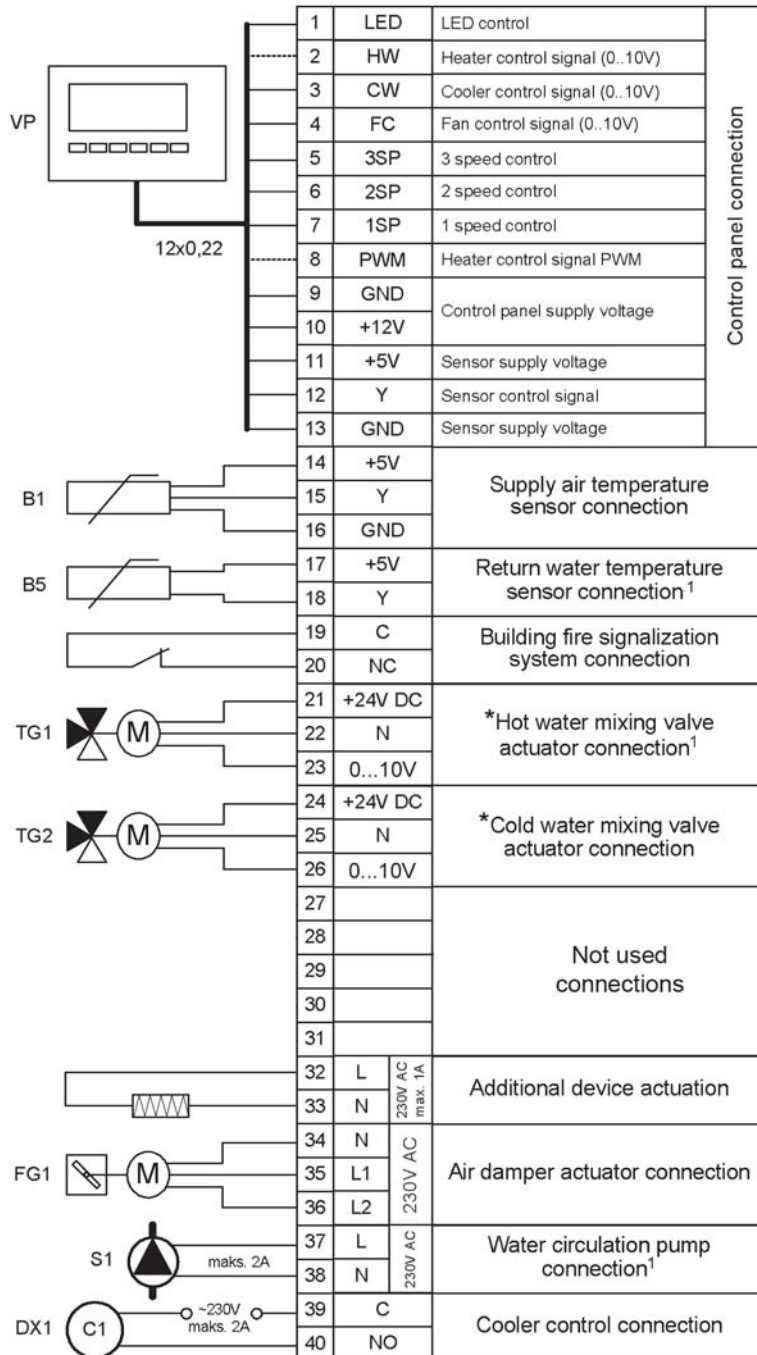
Control System External Elements Connection Diagram



 Normally closed contact. Do not connect voltage!

¹ Used only in the units with hot water air heater

* Use electric actuators intended for **direct current supply** only

1.3. Temperature Sensors Installation

Supply air temperature sensor is mounted in the air duct in a projected place for it; after heater or cooler section (if provided). The minimal distance from the air vent of the unit up to the sensor should be not less than diagonal of rectangular connection.

Water temperature sensor is mounted on the return water pipe, as close as possible to the heater case. It is recommended that the sensor would be thermo insulated!



Temperature sensors and control panel connections must be sealed with PVC isolation tape.

1.4. Control Panel Installation Requirements

1. Control panel must be installed in the room under given following conditions:
 - 1.1. ambient temperature range 0°C ... 40°C;
 - 1.2. relative humidity limits 20% ... 80%;
 - 1.3. protection must be ensured from accidentally vertically falling water drops (IP X2).
2. Installation height must be not less than 0,6m from the ground.
3. Control panel connection is projected through the hole in its backside.
4. Control panel is fixed after screwing two holes on the fastening surface.

1.5. Control Panel Connection

Panel connection terminals position is shown in the 1.5 picture (on the right side).

Control panel is connected to the connection terminals (see 1.2 Picture). The length of the cable connecting the control panel with the unit should not exceed 20 m. Cable type is specified in unit wiring diagram.

1.5 Picture

Control Panel Diagram

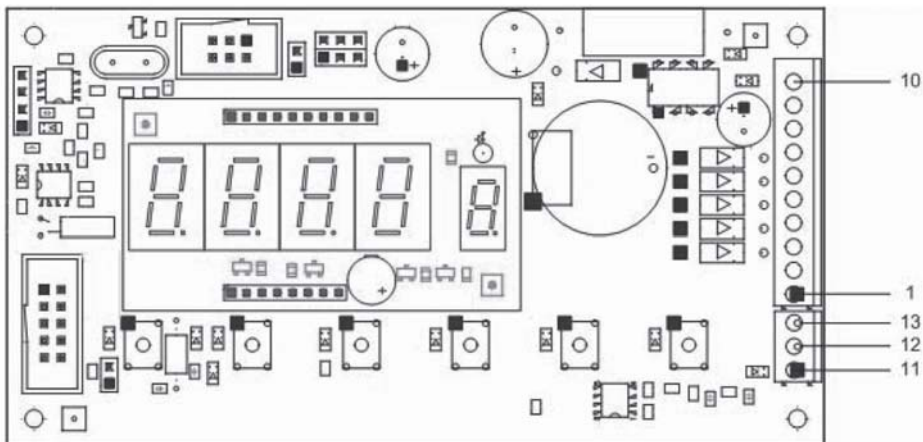

Control panel connection and other cable thicknesses are specified in the wiring diagram!

2. OPERATION MANUAL

2.1. Unit Control

Air handling units control system ensures control of the physical processes that are taking place inside the air handling unit. Automatic control system consists of:

- the C2 controller which is integrated into a control panel;
- control board and external elements connection board, mounted inside the unit;
- damper actuators;
- temperature sensors.

The control panel (2.1 Picture) can be installed in any user-friendly place and is intended for remote control of air handling unit. Control panel display allows monitoring supply air temperature, unit operation modes and other. Control panel red light diode indicates unit failures. Air temperature, ventilation intensity, operation modes and other parameters are set by the buttons.

2.1 Picture

General View of the Control Panel





Buttons located on the control panel mean:

 start up / shut down of the air handling unit;

 entry to parameters change menu / return to main menu;

 parameters setting;

 parameters confirmation;

  navigation in the menu / parameters value change.

2.2. Switching on the Unit

After connecting the unit to the electrical power supply, on the control panel displays start-up window, this is shown in the 2.3 Picture.

Unit is switched on (off) by pressing and holding for 4 - 5 seconds  button. After switching on, unit will start operating after short delay, until air dampers open up, and fans start running. Unit operation is indicated in the control panel by ventilation intensity level and operation symbol (see further).

 Do not switch on the unit without connected earthing! Make sure, whether all unit sections (if intended) are tightly interconnected.

2.3. Control Panel Indication

The information is presented to the user on the display of a control panel by means of numbers and symbols, also light signals of a red light-emitting diode.

Controller panel display start-up window is shown in the 2.3 Picture.

2.3 Picture

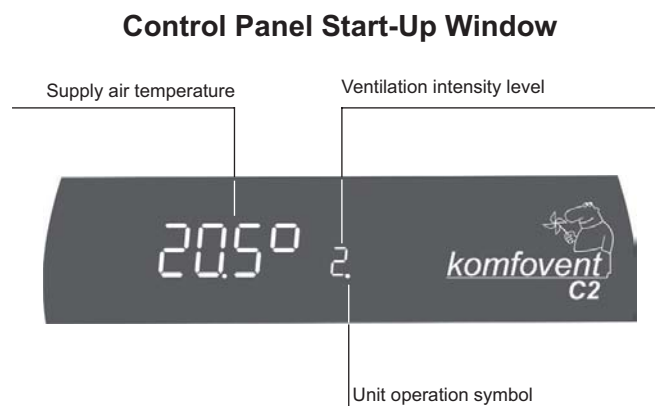



Note: If after powering the unit up and pressing the start up button the sign “Stop” is lit on the control panel display and the unit does not start it is necessary to follow the troubleshooting table (see below).

Light Diodes Indication:



1. supply air temperature is displayed only – **unit has been stopped;**
2. supply air temperature, ventilation intensity level and unit operation symbol are displayed – **unit is operating in manual mode;**
3. the same as listed in previous item, only instead ventilation intensity level the letter “A” is displayed – **unit is operating in automatic mode;**
4. supply air temperature and unit operation symbol are displayed only – **the unit operates in an automatic mode, but according to programmed working schedule it is stopped;**
5. the red diode is flashing – see 2.6. chapter.
6. the red diode is flashing and/or “Stop” sign is shown – **the emergency shutdown of the unit** (see 2.6. chapter);
7. nothing is showing on the control panel – **unit does not have electric power supply or control panel connection cable is damaged.**

2.4. Unit Programmable Settings



After pressing button **MENU** on the control panel, and holding it pressed for 4 seconds, enter the menu mode. By pressing buttons ,  menu window is selected (see description further).

Note: Menu is escaped the same way by pressing and holding **MENU** button for 4 seconds, or waiting for 2 minutes till start-up window appears automatically.

1. Ventilation intensity setting

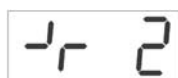

Ventilation intensity level choosing possibility is provided in the unit. To set ventilation rate, select menu window with ,  buttons:

 – ventilation intensity level





Button **SET** lets to enter the menu of ventilation intensity adjustment, and by buttons ,  the necessary level from **1 up to 10** (in some units adjustment of levels only from 1 up to 3 is provided) can be chosen. To confirm the selected level, press **OK** button.

Note: After setting on the control panel maximal ventilation intensity level (10), on the start-up window is shown only digit 9.



2. Supply air temperature setting

The air handling unit maintains the supply air temperature preset by the user. To set the temperature value, select menu window with ,  buttons:





 – supply air temperature (set point)

Mark the first temperature-setting symbol with **SET** button, set the required value with  or  button. Shift to the other symbol by pressing **SET**, change the value of the symbol with , . To confirm the selected value of the supply air temperature, press the **OK** button.



3. Setting the time and the day of the week

For the unit to operate properly in automatic mode, the time and the day of week should be set. For the purpose, select menu window with ,  buttons:



 – time and day of the week

Mark the first symbol with **SET** button, set required value with  or  button, then mark the next symbol with **SET** button, etc. Pressing **SET** after the time setting, the small digit standing for the day of the week starts flashing. Press ,  buttons to select the day. In order to confirm the entered day and time, press **SET** button.

4. Weekly schedule setting

For setting the weekly schedule for automatic operation mode of the air handling unit, select menu window with ,  buttons:





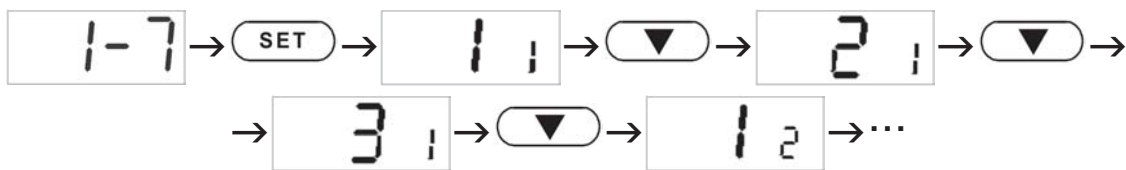

By pressing  weekly operating schedule programming is entered. For each day (twenty-four hours) it is possible to program 3 events. Press  or  button to select the needed event for the day of the week:







The big number stands for the event number, and the small one for the day of the week. After selecting the event (period) to be set press  button, and so it is proceeded for the set up of the starting time of the selected event:



By further pressing  button all numbers are selected. The value of the flashing number is being changed by ,  buttons. After setting the time of the start point of the unit the window for the time of the switching off (ending) is selected by pressing  button:



The shutdown time is marked by the dot at the end

By pressing  button all numbers are selected. With ,  the values are changed. By pressing  button the unit comes back to the previous window to select the day of the week, and same previously stated moves are performed. After setting the weekly schedule, the  button is pressed once again to come back to the previous menu.

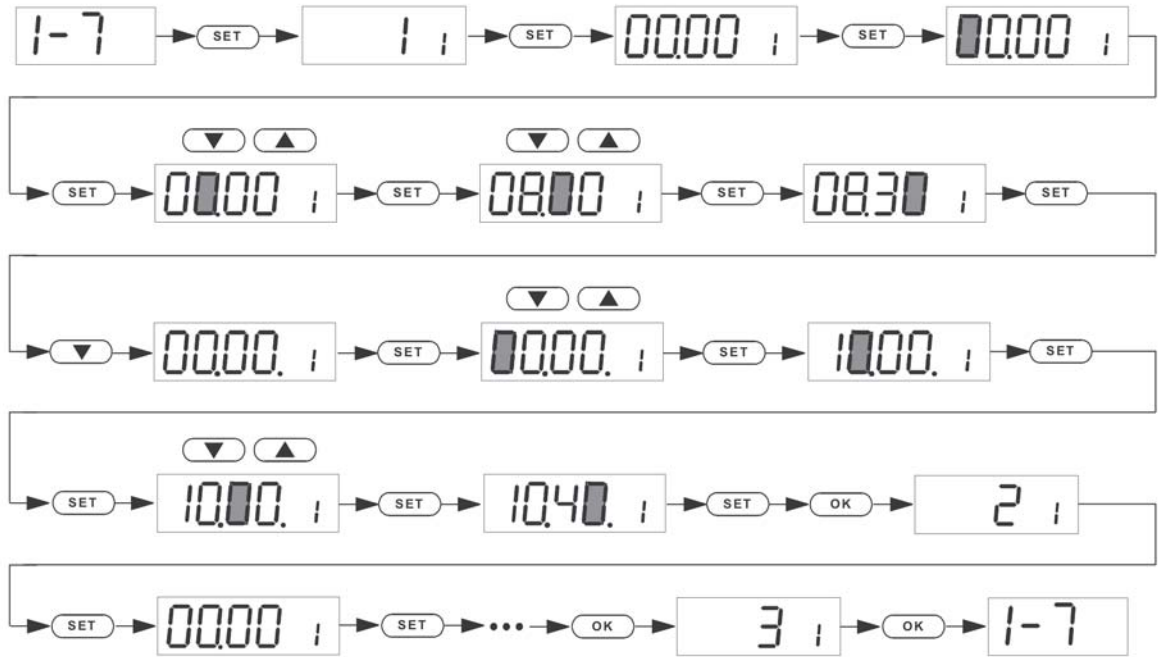

The example of setting the weekly schedule:



Note: Times of not usable events must be set to zero if you use not all events of week day.

5. Unit operation mode setting



Two unit operation modes are available: manual and automatic. The unit performs in the manual mode all the time till it is switched off by pressing  button. The unit performs in automatic mode according to weekly schedule (see the above weekly schedule setting).

To set the operation mode the menu window is selected with ,  buttons:



or – unit operation modes

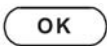

The operation mode is set by pressing  button, with ,  buttons the needed mode is selected: automatic **A** or manual **n**. The  button is pressed to confirm the mode.

2.5. Other Control Functions

Actuation of the additional external device

Any external device being connected to the board contacts (see 1.2a Picture) is actuated when unit is switched on. When the unit is switched on, alternating 230V voltage appears on contacts 32, 33. After switching off the unit, fans will stop and air damper will be closed, operating voltage will disappear.

2.6. Troubleshooting

- If the unit is inoperative:
 - Make sure the feeding cable is plugged into an electrical outlet.
 - Check all safety fuses of the automatic control block. In case of need, replace the faulty fuses with the new ones of the same electric parameters (fuses parameters are in wiring diagram).
 - Check if the control panel does not show the “Stop” sign. In such case failure has to be eliminated. For the purpose, be guided by Table 2.6, presenting failure description.
 - Should the remote control panel be blank and the display screen be not lighted, check the integrity of the cable connecting the control panel with the unit.

According to the damage level, the air-handling unit may be either stopped or not. If the unit is being stopped the control panel display shows “Stop” sign (see Picture 2.6).

2.6 Picture

Failures Displayed on the Control Panel and Possible Fault Causes

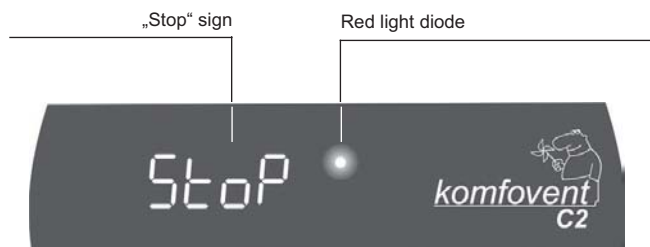

2.6 Table

The unit works	Red colour light diode	Indication of the control panel	Possible fault cause
Yes	Flashes (blinks) every second	The temperature is shown, the ventilation rate or automatic mode is indicated (A)	Supply air filter is clogged. It must be changed.
No	Shines	“Stop” sign is shown	Return water low temperature. Frost of heater returns water possibility.
No	Does not shine (no light)	“Stop” sign is shown	Electric heater overheating (if provided). Getting fire alarm from the fire-prevention system. Temperature sensor not connected or faulty.

 The emergency protection may be restarted with the “RESET” button only following the heater overheating cause isolation and troubleshooting.

- If the unit is shut down and control panel shows text message “Stop”, the failure must be eliminated!
- Before starting any operations inside the unit, make sure that the unit is switched off and the power supply voltage is shut off.

Having eliminated failure, unit is restarted by the button after what it continues its operation in the previous mode. However, if failure is not eliminated, air handling unit will not be started-up, and on the control panel will be displayed “Stop” message.

KOMPAKT OTK FUNCTIONAL DIAGRAM

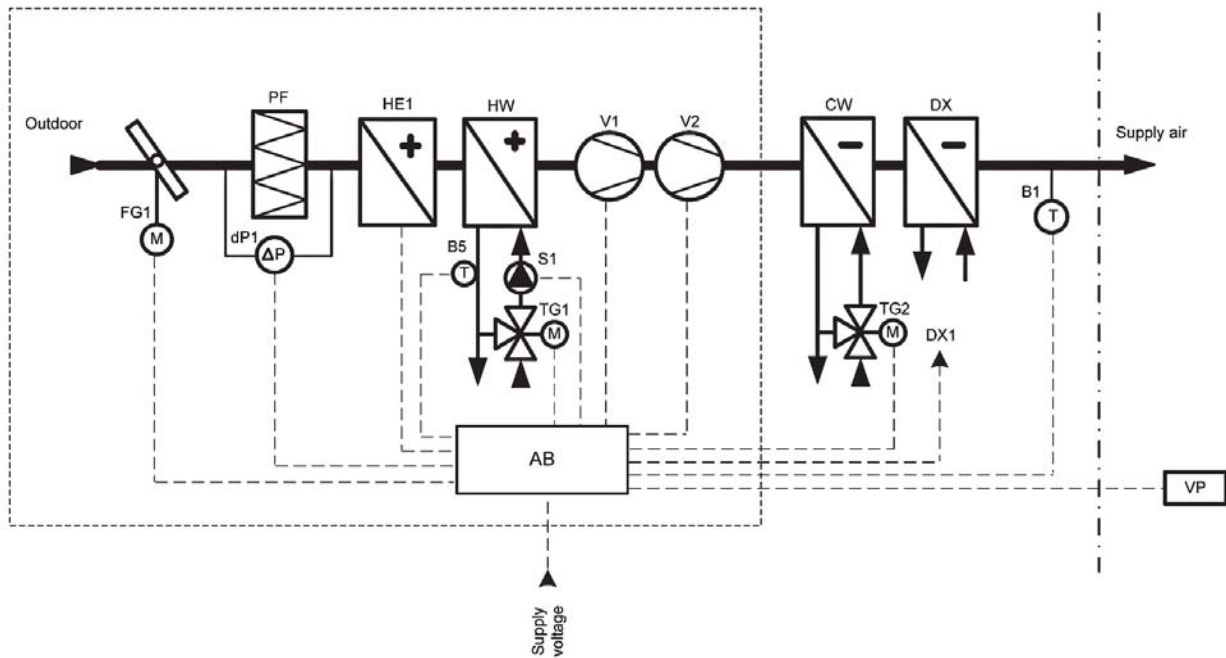

Note: position of the detailed item (bend) is indicated in the drawing of specific unit.

AB	Control box	HW	Water heater
B1	Supply air temperature sensor	PF	Air filter
B5	Return water temperature sensor	S1	Circulation pump
CW	Water cooler	TG1	Hot water mixing valve actuator
DX1	DX cooling control	TG2	Cold water mixing valve actuator
dP1	Pressure switch for filter	V1, V2	Supply air fan
FG1	Supply air damper actuator	VP	Control panel
HE1	Electric heater		

Depending on the unit type, various automation system principle solutions are possible. Electrical connection of the particular unit is specified in the principal electric diagram.

Descriptions of used markings in the diagrams are specified in the table.

Table

Specification of the Components

Marking	Description
C2-P1	External connections board
C2-OTK	Control board
dP1	Supply air filter differential pressure switch
EK1, EK2	Electric heater steps
F_	The fuse
K1, K2	Relay 30A, 230V AC
SA1	“Winter / Summer” season switch
SIMI-4	Triac 40A
TK1	Electric heater 80°C overheating protection (automatic reset)
TK2	Electrical heater 120°C overheating protection (manual reset)
TK3.1, TK3.2	Triacs 70°C overheating protection (automatic reset)
TR1	The autotransformer 0-105-130-145-160-230V AC
V1, V2	Supply air fan
XT1	Power supply connection terminal blocks

KOMPAKT OTK-1200PW, 2000PW Wiring Diagram No. 1

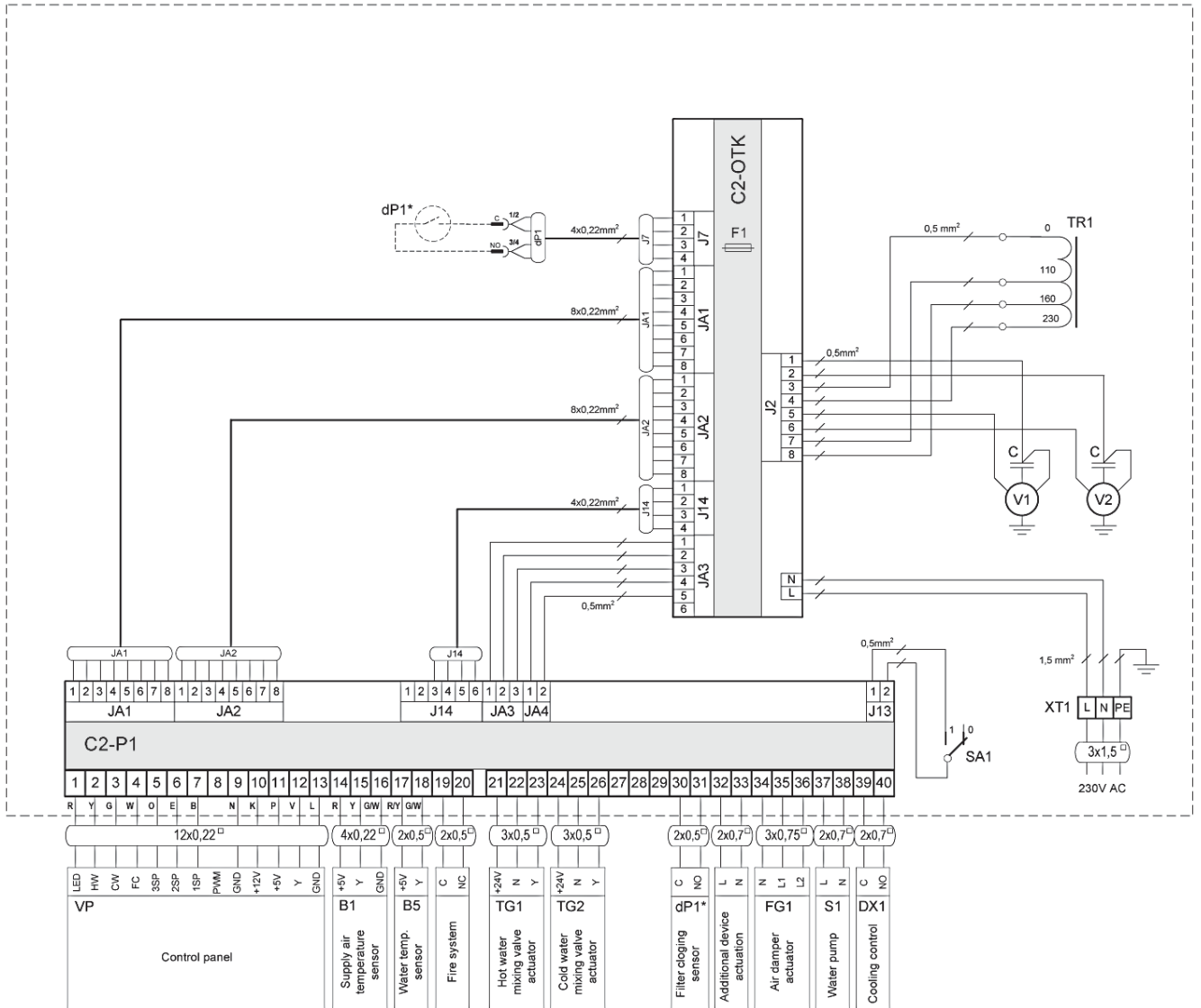

	OTK-1200PW	OTK-2000PW
V1, [W/A]	290/1,24	290/1,24
V2, [W/A]	-	290/1,24
TR1, [A]	1	2
F1, [A]	T 2	T 3,15
XT1 [mm ²]	1,5	1,5

Configuration of the switches C2-OTK board:



Colors marking:

- R - red;
- Y - yellow;
- G - green;
- W - white;
- O - orange;
- E - grey;
- B - blue;
- N - brown;
- K - black;
- P - pink;
- V - violet;
- L - light blue.

Note:

* not used

KOMPAKT OTK-700PE3 Wiring Diagram No. 2

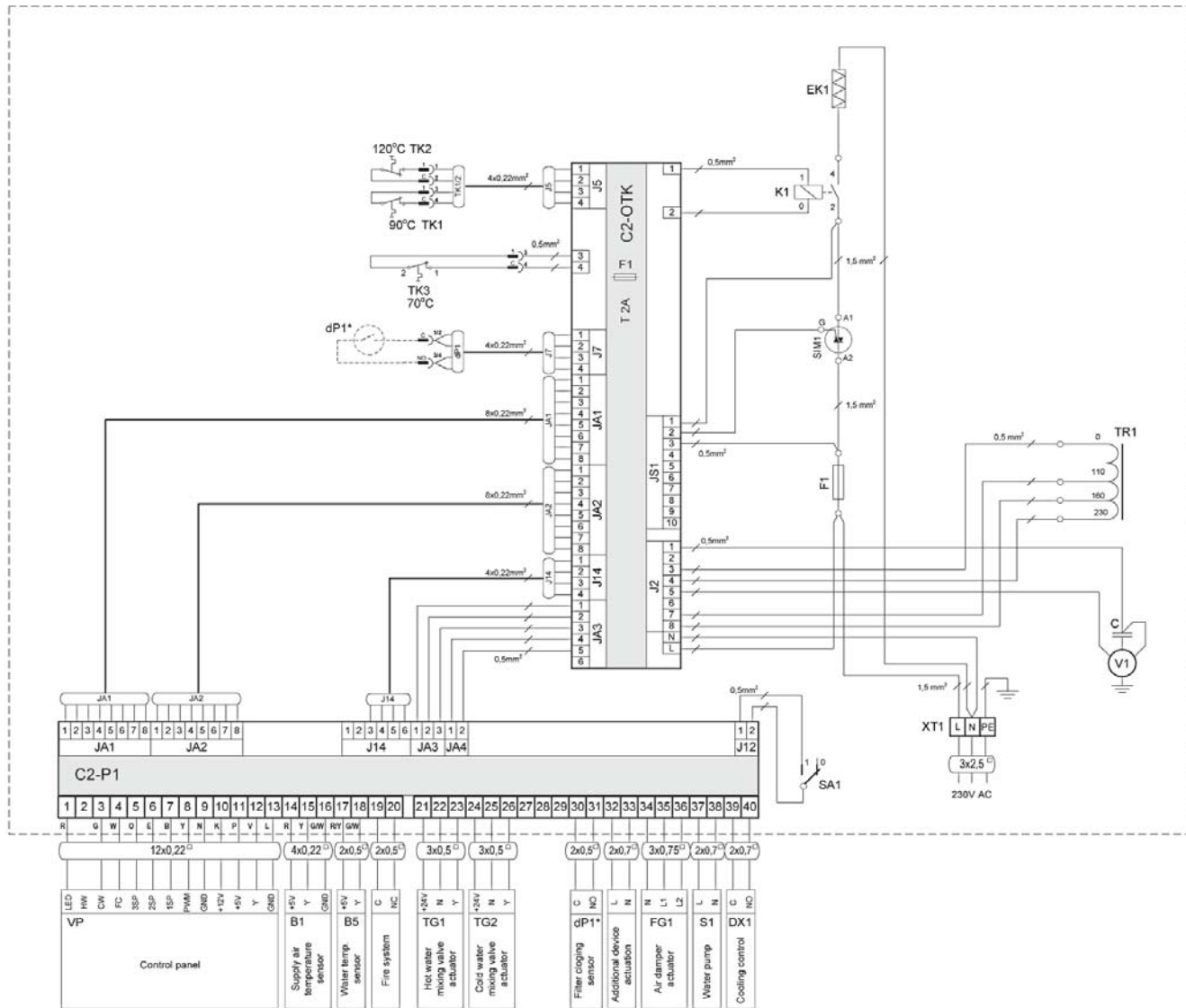

	OTK-700PE3
EK1, [kW]	3
K1, 30A	+
V1, [W/A]	165/0,71
TR1, [A]	1
SIM1, 40A	+
TK3 70C	+
F1, [A]	FF 16
XT1 [mm ²]	2,5

Configuration of the switches C2-OTK board:



Colors marking:

- R - red;
- Y - yellow;
- G - green;
- W - white;
- O - orange;
- E - grey;
- B - blue;
- N - brown;
- K - black;
- P - pink;
- V - violet;
- L - light blue.

Note:
* not used

KOMPAKT OTK-700PE, 1200PE Wiring Diagram No. 3

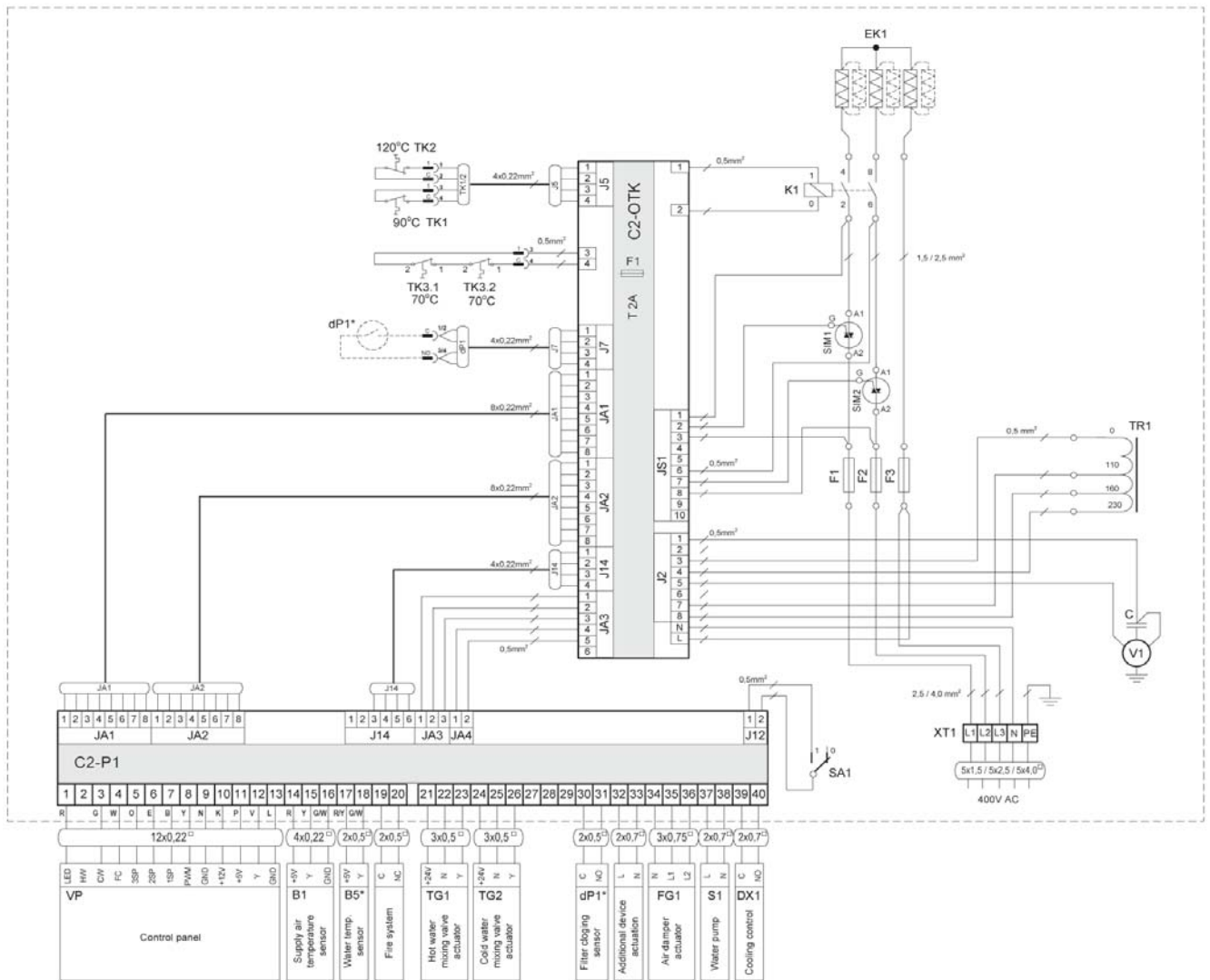

LED	12x0,22 [□]	4x0,22 [□]	2x0,5 [□]	2x0,5 [□]	3x0,5 [□]	3x0,5 [□]	2x0,5 [□]	2x0,7 [□]	3x0,75 [□]	2x0,7 [□]	2x0,7 [□]
VP	Control panel	B1	B5*	Fire system	TG1	TG2	dP1*	Additional device actuation	FG1	S1	DX1
VP	Control panel	Supply air temperature sensor	Water temp. sensor	Fire system	Hot water mixing valve actuator	Cold water mixing valve actuator	Filter clogging sensor	Additional device actuation	Air damper actuator	Water pump	Cooling control

	OTK-700PE6	OTK-700PE9	OTK-1200PE9	OTK-1200PE15
EK1, [kW]	3x2	3x3	6x1,5	6x2,5
K1, 30A	+	+	+	+
V1, [W/A]	165/0,71	165/0,71	290/1,24	290/1,24
TR1, [A]	1	1	1	1
SIM1, SIM2, 40A	+	+	+	+
TK3.1, 70C	+	+	+	+
TK3.2, 70C	-	-	+	+
F1 - F3, [A]	FF 10	FF 16	FF 16	FF25
XT1 [mm ²]	1,5	2,5	2,5	4,0

Configuration of the switches C2-OTK board:

- Colors marking:**
- R - red;
 - Y - yellow;
 - G - green;
 - W - white;
 - O - orange;
 - E - grey;
 - B - blue;
 - N - brown;
 - K - black;
 - P - pink;
 - V - violet;
 - L - light blue.

Note:
* not used

KOMPAKT OTK-2000PE Wiring Diagram No. 4

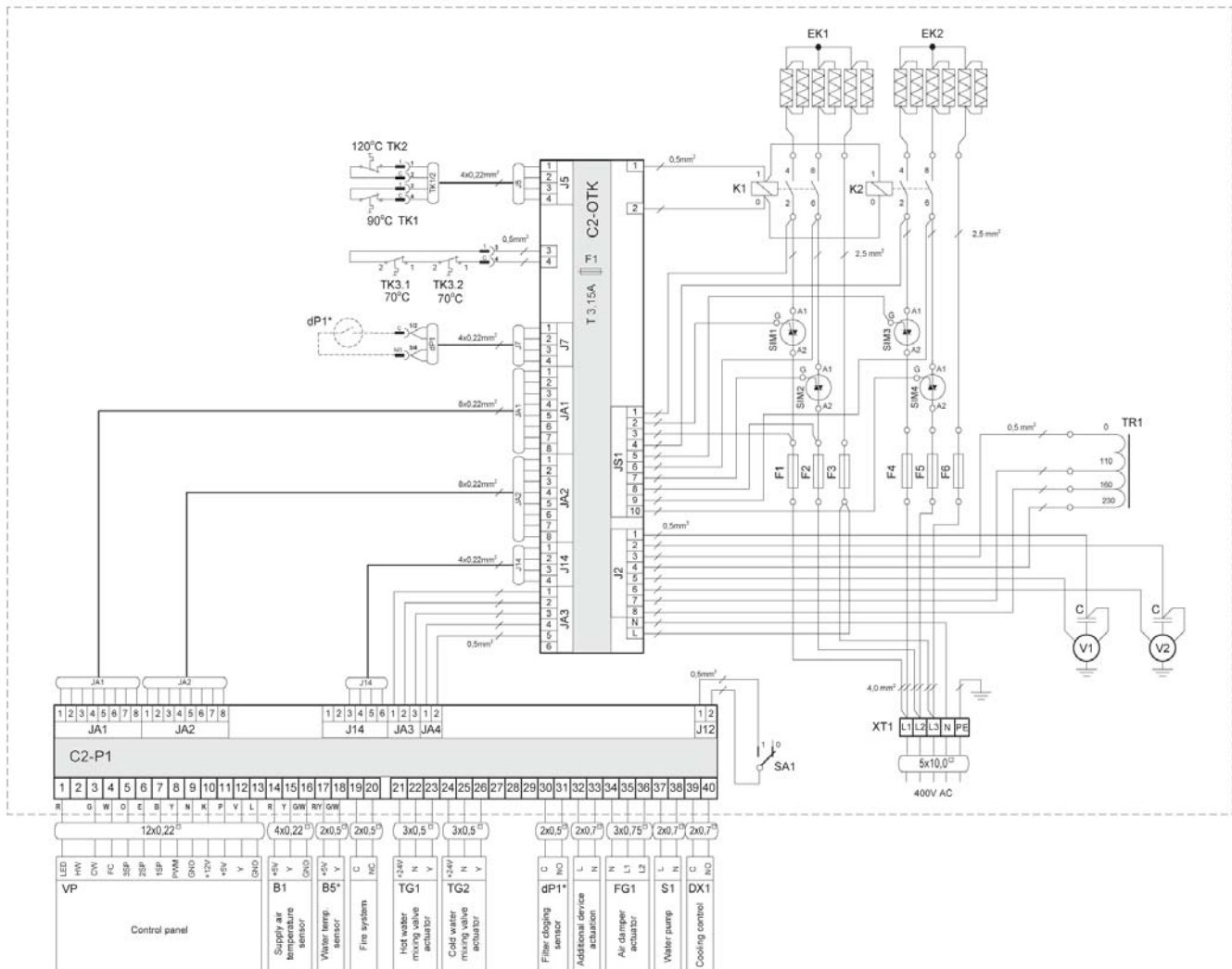

	OTK-2000PE22,5	OTK-2000PE30
EK1, [kW]	6x2,5	6x2,5
EK2, [kW]	3x2,5	6x2,5
K1; K2, 30A	+	+
V1; V2, [W/A]	290/1,24	290/1,24
TR1, [A]	2	2
SIM1-SIM4, 40A	+	+
F1 - F3, [A]	FF 25	FF 25
F4 - F6, [A]	FF 16	FF 25
XT1 [mm ²]	10,0	10,0

Configuration of the switches C2-OTK board:



Colors marking:

- R - red;
- Y - yellow;
- G - green;
- W - white;
- O - orange;
- E - grey;
- B - blue;
- N - brown;
- K - black;
- P - pink;
- V - violet;
- L - light blue.

Note:

* not used



UAB AMALVA

Ozo str. 10, LT-08200 VILNIUS, LITHUANIA
e-mail info@amalva.lt
www.amalva.com
www.komfovent.com