



KOMPAKT RECU

Series Air Handling Units with C3 Control System
Electrical Installation and Operation Manual

Table of Contents

1. INSTALLATION MANUAL	4
1.1. Air Handling Units Sections Connection	4
1.2. Electric Power Supply Connection	4
1.3. External Elements Connection	5
1.4. Temperature Sensors Installation	5
1.5. Installation of the air by-pass channel damper	5
1.6. Control Panel Installation Requirements	7
1.7. Control Panel Connection	7
2. OPERATION MANUAL	8
2.1. Unit Control	8
2.2. Switching on the Unit	9
2.3. Control Panel Indication	9
2.4. Unit Programmable Settings	10
2.5. Other Control Functions	17
2.6. Unit PC control	18
2.7. Troubleshooting	19
Unit Functional Diagram	21
Specification	22
Wiring Diagram	23

1. INSTALLATION MANUAL

Installation works can be performed only by the specialists that have required qualification. During installation following requirements must be fulfilled.

 It is recommended to lay control cables separately from power cables, or use shielded cables. In such case it is necessary to earth cable shielding!

1.1. Air Handling Units Sections Connection

After unit parts have been connected together (see unit installation instruction), unit sections connecting cables and wires are connected.

 Connector connection is performed strictly according to numeration given in wiring diagram, or adequate markings (see unit electric scheme).

 When disconnecting unit sections, do not pull by connecting wires and cables!

1.2. Electric Power Supply Connection

If the air handling unit voltage is ~230V; 50 Hz it is necessary to install the socket with grounding of corresponding capacity (see electric diagram). If the voltage is ~400V; 50 Hz, the cable of electrical power supply is connected to the main switch, which is located on the unit's outside wall. It is necessary to connect earthing! Types of cables of connection of electrical power supply are specified in 1.2 Table:

1.2 Table

Electrical Power Supply Cable Types

Air Handling Unit Type	Cable type
RECU-3000HW; RECU-4000HW	5 x 1,5 mm ² (Cu)
RECU-3000HE; RECU-4000HE	5 x 10,0 mm ² (Cu)

 Air handling units designed for 400V AC supply voltage must be connected to the stationary installation by solid cable. All units with air flow up to 2000 m³/h (inclusively) must be connected through circuit breaker with max. 30mA current leakage protection, and units from 3000 m³/h - with 300mA current leakage protection.

 Before connecting unit to the electrical power supply, it is necessary to check whether earthing has been installed properly.

1.3. External Elements Connection

On the air handling unit wall it is provided connection box. To the terminals which are inside the box (1.3 Picture) all external control elements are connected.

External elements connection diagram is given in the 1.3a Picture.

1.3 Picture

Connection Board C3-P1

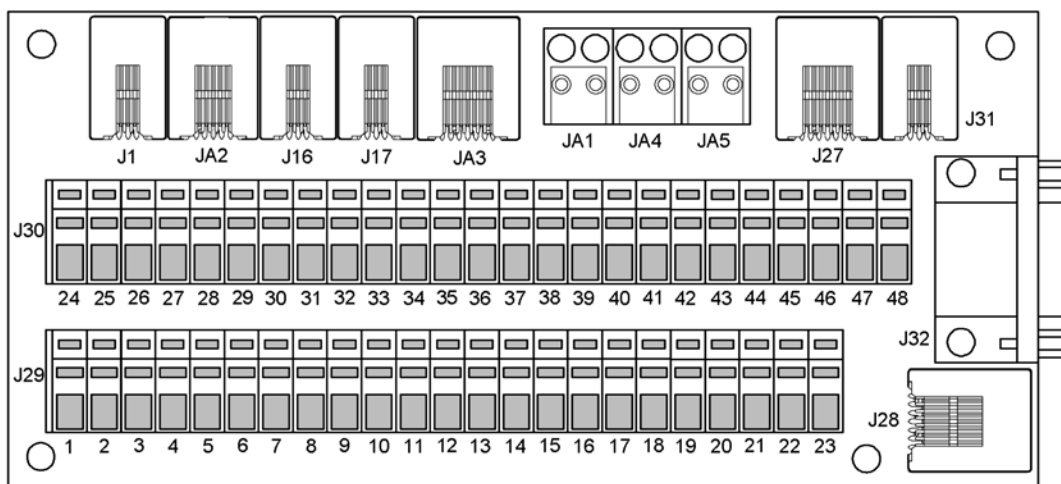

 If the unit has PC control function, computer network (“Ethernet”) or Internet is connected to the connection board socket J28. There is an option to connect computer with RS-232 interface to the socket J32 (more detailed description is given in the 2.6. chapter).

1.4. Temperature Sensors Installation

Supply air temperature sensor is mounted in the air duct in a projected place for it; after electric heater or cooler section (if provided). The minimal distance from the air vent of the unit up to the sensor should be not less than double diameter of the circular connection or a diagonal of rectangular connection.

Water temperature sensor is mounted on the return water pipe, as close as possible to the heater case. It is recommended that the sensor would be thermo insulated!

 Temperature sensors and control panel connections must be sealed with PVC isolation tape.

1.5. Installation of the air by-pass channel damper

The by-pass channel damper actuator of the plate-type heat exchanger is mounted on the axle and fixed to the wall of the unit. Before installation, the damper must be set to the original position, i.e., the air by-pass channel must be opened if the unit is switched off. After installation, the actuator rotation direction must be checked! To change the rotation direction, switch over the changeover on the actuator.

1.3a Picture

Control System External Elements Connection Diagram

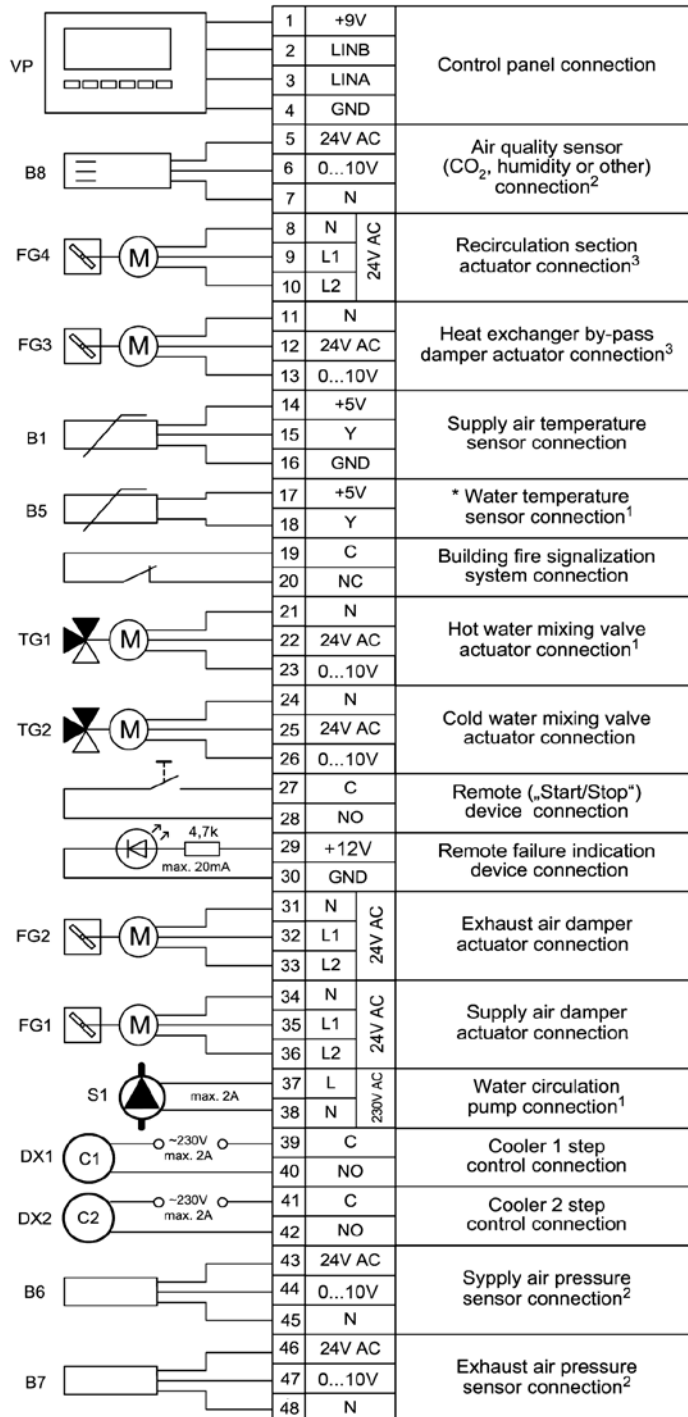

 Normally closed contact. Do not connect voltage!

 Control contact. Do not connect voltage!

¹ used only in the units with water heater.

² additional ordered function.

³ external actuator connection (not used in KOMPAKT RECU units).

* used only in the units with ducter water heater.

1.6. Control Panel Installation Requirements

1. Control panel must be installed in the room under given following conditions:
 - 1.1. ambient temperature range 0°C ... 40°C;
 - 1.2. relative humidity limits 20% ... 80%;
 - 1.3. protection must be ensured from accidentally vertically falling water drops (IP X2).
2. Installation height must be not less than 0,6 m from the ground.
3. Control panel connection is projected through the hole in its backside.
4. Control panel is fixed after screwing two holes on the fastening surface.

1.7. Control Panel Connection

Panel connection terminals position is shown in the 1.7 Picture (on the right side).

Control panel is connected to the connection box terminals (see 1.3 Picture). The length of the cable between the control panel and the unit should not exceed 150 m. Cable type is specified in unit wiring diagram.

1.7 Picture

Control Panel Wiring

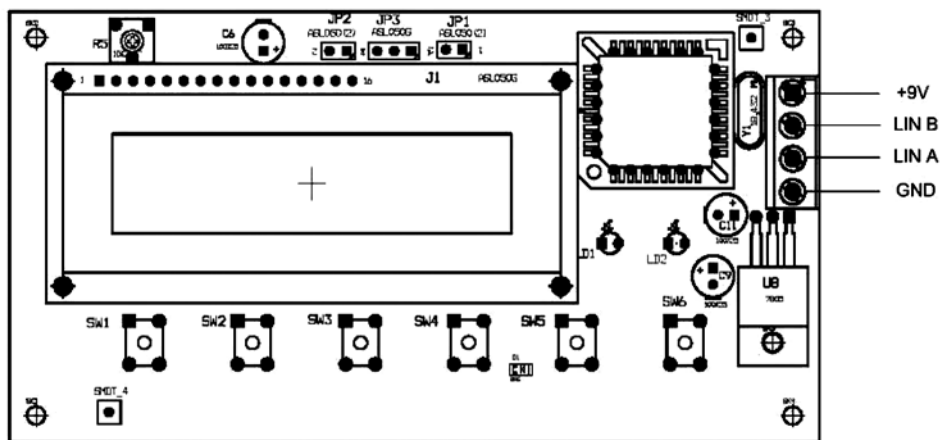

 Control panel connection and other cable thicknesses are specified in the wiring diagram!

2. OPERATION MANUAL

2.1. Unit Control

Air handling units control system ensures control of the physical processes that are taking place inside the air handling unit. Control system consists of:

- controller board;
- fuses, power and intermediate control boards, which are installed inside the unit;
- control panel, which can be installed in the convenient place for the user;
- air damper actuators;
- pressure and temperature sensors.

Control panel (2.1 Picture) is designed for remote air handling unit control, setting and display of controller parameters. Control panel LCD display with backlight allows monitoring various parameters and text messages. Controller light signals indicate unit operation modes and failures. Air temperature, ventilation intensity, operation modes and other parameters are set by the buttons.

2.1 Picture

General View of the Control Panel

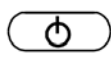

Buttons located on the control panel mean:

 start up / shut down of the air handling unit;

 entry to parameters change menu / return to main menu;

 parameters setting;

 parameters confirmation;

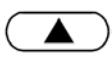
  navigation in the menu / parameters value change.

2.2. Switching on the Unit

After connecting the unit to the electrical power supply, on the control panel LCD displays start-up window, this is shown in the Picture 2.3.

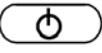
Unit is switched on (off) by pressing and holding for 4 - 5 seconds  button. After switching on, unit will start operating after short delay (about 30 - 40 seconds), until air dampers open up, and fans start running. Unit operation is indicated in the control panel by ventilation intensity and light diode signals (see further).

 Do not switch on the unit without connected earthing! Make sure, whether all unit sections are tightly interconnected.

2.3. Control Panel Indication



Data is presented to the user on the control panel LCD display by numbers and text messages, also by two light diode signals.

Controller display start-up window is shown in the 2.3 Picture.

2.3 Picture

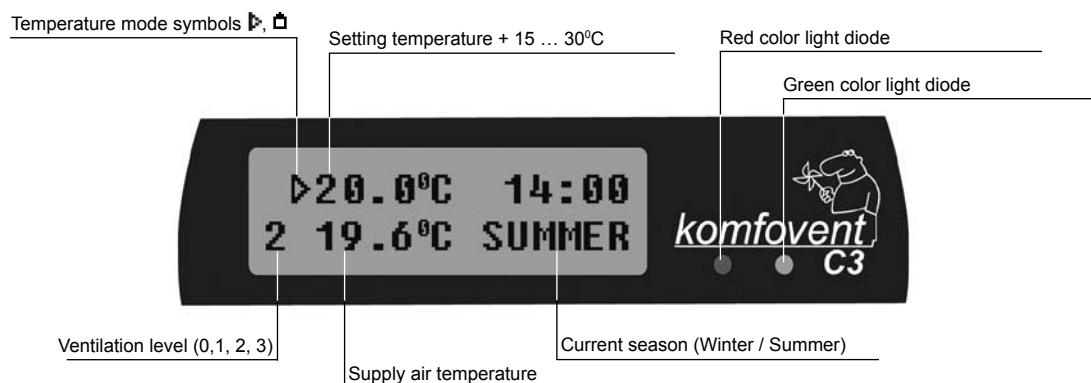
Control Panel Start-Up Window



If you want change control panel start-up window to the air flow or temperature values indication window, push both button ,  and current window will be changed to 4 or 9 menu window (see 2.4.chapter).

Light Diode Indication:

1. No green light diode signal indication on the panel - **unit has been stopped.**
2. Green light diode signal on the control panel and text message is shown - **unit is operating in automatic mode.**
3. Green light diode signal is blinking and text message is shown - **unit is operating in manual mode.**
4. Red light diode signal is blinking and text message is shown - see 2.7. chapter.
5. Red light diode signal on the control panel and text message is shown - **emergency unit shut down** (see 2.7. chapter).
6. Nothing is showing on the control panel - **unit does not have electric power supply.**

Note: By pressing any button on the panel automatically switching on the display backlight. Backlight is off after 2 min. when no buttons are pressed.

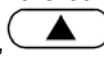

2.4. Unit Programmable Settings

After pressing button **MENU** on the control panel, and holding it pressed for **4 seconds**, enter the menu mode. By pressing buttons ,  menu window is selected (see description further).



Note: Menu is escaped the same way by pressing and holding **MENU** button for 4 seconds, or waiting for 2 minutes till start-up window appears automatically.

1. Unit operation modes setting

Two unit operation modes are possible: manual and automatic. In manual mode unit operates continuously by set ventilation intensity. In automatic mode unit works according to weekly schedule (see further weekly schedule setting).

To set operation mode, select menu window with the buttons , :

MODE :
MANUAL, AUTO



After pressing button **SET**, operation mode settings appear, by pressing ,  buttons desirable mode is selected: **MANUAL** or **AUTO**. Selected mode is confirmed with **OK** button.

2. Air volume control setting



Supply and exhaust air volumes control modes have been projected in the unit:

- Constant air volume (CAV) control mode - unit supplies and exhausts constant air volume preset by the user, independent of the processing changes in the ventilation system;
- Variable air volume (VAV) control mode - unit supplies and exhausts air volume correspondingly to the ventilation requirements in different premises. In case of frequently changing ventilation demands this air volumes maintenance mode signally reduces unit exploitation costs.

Note: Variable air volume control mode is an option and must be ordered additionally.

To set air volume control mode, select menu window with the ,  buttons:



AIR VOLUME :
CAV, VAV

After pressing **SET** button, air volume control mode settings appear, and by pressing ,  buttons desired control **CAV** or **VAV** is selected and confirmed with **OK** button.



If air handling unit is provided with **variable air volume control function**, primary control mode calibration (look further) is essential, otherwise after choosing VAV mode unit will not operate.

Variable air volume control mode calibration:

1. Before activating the device you should adjust air distribution and exhaust devices in ventilation system, open all valves for variable air flow in a way enabling air supply to all ventilated premises.
2. Switch on the unit and by choosing menu window for air volume control setting (see above) actuate constant air volume maintenance mode.
3. After choosing the CAV mode and being at the same menu window ,  buttons must be pressed together. After pressing both buttons, calibration will last 3 minutes and during this time unit will start to work on maximum ventilation intensity.
4. After finishing the calibration process, air handling unit further will operate in the previously settled mode.





 Panel's menu window intended for air volume control setting is provided only with the units having air flow maintenance function.

3. Setting ventilation level







Three ventilation levels have been projected in the unit: 1, 2 and 3. Each of these levels may be set for manual or automatic operation mode. To set ventilation level in manual mode, select menu window with the buttons



VENTILATION: 2
SUPP.50% EXH.40%

After pressing button , operation ventilation level settings appear, by pressing , , buttons desirable level is selected: **1, 2 or 3**. Selected level is confirmed with  button.

Note: In the air handling units provided with **the air flow maintenance function** for each of three ventilation intensity levels maintained air flow can be adjusted and set separately for supply and exhaust air. It can be set from 0 up to 100% by 10% steps. In the unit **without this function** ventilation intensity is only included.

Ventilation intensity (or maintained air flow) is adjusted by pressing  button and after selecting desired **1,2 or 3** level,  button is pressed one more time. Supply air intensity blinking value is changed by the buttons , , from 0 up to 100%. After pressing button  again, exhaust air intensity value is set the same way. Selected level is confirmed with  button.

4. Air handling unit air flow indication

After selecting desired intensity (from 0 to 100%), air handling unit will supply and exhaust constant air flow which user may monitor in the information window.

Example: If unit designed air volume is 10.000 m³/h, then after setting supply and exhaust air intensity 100%, unit will maintain 10.000 m³/h. Reducing setting down the 50%, 5.000 m³/h air flow will be maintained accordingly.

To monitor unit air flows by pressing ,  buttons menu window has be selected:

SUPP. 10560 m³/h
EXH. 10040 m³/h

Note: If the variable air volume control function is actuated, unit can maintain signally lower (or higher) air flow than that preset by the user.

 Air flow indication window is provided only with the units having **air flow maintenance function**.







5. Exhaust air flow correction

Set air flow intensity (or maintained air volume) for specified time period can be corrected -50% till +50% from set value.

Example: after reducing exhaust air flow intensity, for some time overpressure will be caused (sometimes needed to start the fireplace or such).

For exhaust air flow correction by the buttons ,  menu window is selected:

EXH.CORRECTION:
OFF -50% 30min.

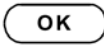
After pressing button , exhaust air ventilation correction settings appear, by the ,  buttons chosen “**ON**” - correction function on, or “**OFF**” - function off. Then by pressing button , with buttons , , exhaust air correction is set by the percent (-50% .. + 50%), after pressing  correction time is set the same way (0 .. 99 min.) meaning time period, as long as this function has to be activated. Button  is pressed for confirmation.

Note: After this function has been activated unit will work for the set time period with present exhaust correction. After time period is over this function turns off automatically.



 This function is **not provided** in the units with three speed fan control.

6. Setting temperature maintenance mode

Several temperature maintenance options are provided in the air handling unit: supply air maintenance, room (exhaust) air maintenance, automatic.

To set temperature control mode, by pressing buttons , , menu window has to be selected:

CONTROL: AUTO,
SUPPLY, ROOM

By pressing button **SET** control settings appear, by pressing buttons ,  desired temperature maintenance mode is selected, to confirm it button **OK** is pressed.





 After selecting “**AUTO**”, when cooling is needed, unit will work in the room temperature maintenance mode. If the outside temperature will be few degrees lower than set value, control automatically will switch to supply air maintenance mode.



7. Setting temperature value

Air handling unit maintains preset temperature by the user: supply air or room, depending on which control has been selected (see temperature control mode setting).



To set temperature by the buttons , , menu window has to be selected:

SETTING TEMP.:
▷ 20.0°C





By pressing button **SET** first temperature setting symbol is marked, with buttons ,  desired value is set. Shift to the other symbol by pressing button **SET**, change the value of the symbol with buttons , . To confirm selected temperature value button **OK** is pressed.



Note: If before that supply air temperature maintenance mode was set, in the start-up and temperature value setting window symbol  is indicated; if room temperature maintenance - .

8. Setpoint sliding

The setpoint can be shifted -9 to +9 °C from the temperature set value at specified by user time period. To set the setpoint sliding select menu window with the buttons , :

SETPOINT SLIDING
0°C 00:00 00:00

Mark the first symbol with button **SET**, set the required sliding value ($\pm 9^{\circ}\text{C}$) with, ,  buttons, then next by pressing **SET** button and ,  buttons set the setpoint sliding start time and the stop time. To confirm the entered mode, press **OK** button.

By pressing **SET** button enter to the setpoint sliding end time setting. Blinking values are changed pressing ,  buttons. To confirm the entered setpoint sliding period, press **OK** button.

9. Temperature value indication

Without supplied air temperature indication in the control panel start-up window, exhaust (room) and outside temperature indication window has been projected.

To monitor additional temperatures, using ,  buttons menu window has to be selected:

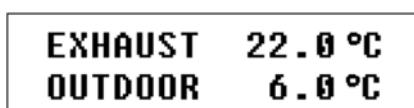







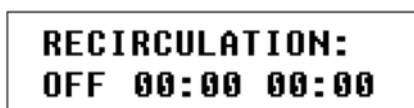



10. Exhaust air recirculation

Air handling unit with recirculation section has air recirculation function, that is, when for a specified time period all exhaust air flow is returned back to the room.

To set recirculation, using ,  buttons, menu window has to be selected::



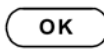

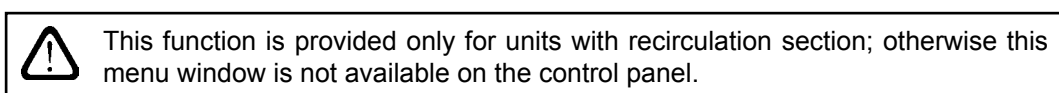
After pressing  exhaust air recirculation settings appear, using ,  buttons is chosen “ON”- recirculation function on, or “OFF”- function off. After pressing  one more time recirculation start time first symbol is marked, with buttons  and  value is set, then with button  another symbol is marked and etc. By pressing button  recirculation end time setting appear. Blinking number value is changed by pressing buttons , . To confirm set air recirculation period  button is pressed.







11. Air quality function setting

Air handling unit has provided option to correct ventilation intensity (or maintenance air volume) according to additional air quality sensor (CO₂, humidity and other).

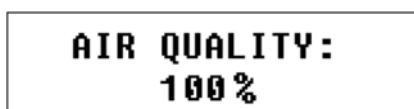
For instance, if the humidity maintaining system is designed in the device, and there is additional humidity sensor, then by setting 65% in the air quality window, and by regulating the intensity of ventilation automatically, humidity of 65% will be maintained, i.e. if humidity increases, ventilation intensity will be increased as well, and if humidity reduces, the device will switch back to the previous mode.

To set air quality function, by buttons , , menu window has to be selected:



By pressing button **SET** first air quality value setting symbol is marked, with ,  buttons desired value is set from 0 up to 100%. Shift to the other symbol by pressing button **SET**, change the value of the symbol with ,  buttons. To confirm selected temperature value button **OK** is pressed.

 This function is provided only in the units with additional sensor; otherwise this menu window is not available on the control panel.



12. Season setting

For the air handling unit operating in most economical mode, summer and winter seasons have been provided.

- By setting "WINTER" season, unit cooling function is blocked.
- By setting "SUMMER" season, unit heating function is blocked.
- By setting "AUTO", automatic season selection will take place. If temperature outside will be lower than 8°C and it will stay like that for a while, unit will start working in winter season mode; otherwise - summer mode.



To set season, pressing ,  buttons, menu window has to be chosen:

**SEASON: AUTO,
SUMMER, WINTER**



After pressing button **SET** season setting are introduced. Pressing ,  buttons season or automatic mode is selected. To confirm set setting **OK** button is pressed.

Note: If air temperature during summer season is insufficient, air handling unit can be preset and for "WINTER" season mode, its energy expenditures will be minimal.



13. Day setting

For the unit proper operation in automatic mode according to the preset weekly schedule, the day of week should be set. To do this using buttons  and  menu window is selected:





**DAY: SU MO
TU WE TH FR SA**

After pressing **SET** button, day of the week settings are introduced, pressing ,  buttons, suitable day of the week is selected. To confirm set setting **OK** button is pressed.

14. Time setting

For the unit proper operation in automatic mode, the real time should be set. To do this menu window is selected pressing buttons ,  :

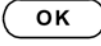

ENTER TIME :
00:00

After pressing  first symbol is marked, with ,  buttons value is set, after pressing button  another symbol is marked and etc. To confirm set time  button is pressed.



15. Weekly schedule setting

Two weekly schedule options settings have been projected:









- “1-5/6-7” - work days and weekend operation schedule;
- “1-7” - unit operation schedule for each day.

To set weekly schedule for air handling unit operation automatic mode, pressing ,  buttons menu window is selected:

SCHEDULE :
1-5/6-7, 1-7





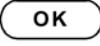

By pressing , buttons ,  desired unit operation program is selected,  button is pressed. After selecting program for each day of the week “1-7” schedule setting window is introduced:

SU 00:00 00:00
N1 0 1 2 3

Each day of the week has 3 events: **N1**, **N2**, **N3**. Settings are started from Sunday (SU). Pressing buttons , , event is selected, which we want to preset. Pressing  button selected event start time settings appear. By pressing button  again, all this event settings are introduced. Blinking number values are changed pressing buttons  and . Then by pressing  button ventilation intensity level (or maintained air volume) settings assigned to this event are introduced. By pressing buttons ,  desired ventilation intensity level is selected: **0**, **1**, **2**, **3**. Preset parameters are confirmed by pressing .

Before selecting work days and weekend operation mode schedule “1-5/6-7” menu window is introduced:

1-5 00:00 00:00
N1 0 1 2 3

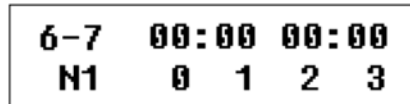

Pressing buttons  and  event is selected (N1, N2, N3), during work days “1-5”. Pressing  and increasing or reducing value using  and  buttons, each event start and end time and ventilation intensity is set the same way. After presetting, pressing buttons  and  weekly schedule setting window “6-7” is selected:

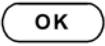



The same way three event operations setting are set for the weekend. To finish weekly schedule programming button  is pressed one more time.

Note: Weekly schedule is programmed only in manual or stopped unit operation..

16. Language setting

Language selection menu has been projected on the control panel. To set language by  and  buttons menu window has to be selected:

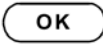

By pressing button  language settings appear. With buttons  and  desired language is selected. To confirm selected language button  is pressed.

2.5. Other Control Functions

1. Unit remote switching on and off

Additional device (such as button, timer or other sensor) is provided to switch the unit on or off. It is connected to the connection box contacts (see chapter 1.3.)

- If the unit is not operating according to programmed week schedule, by connecting (short-circuit) contacts 27, 28 unit will be switched on and will operate with the intensity set in the menu window „VENTILATION“ (see page 11); by disconnecting contacts unit operation will return to previous mode.
- If unit is operating in auto mode with chosen intensity, to switch it off by remote switch contacts 27, 28 must be connected (short-circuit).
- If the information about unit operation mode is requested (when unit is operating and when is not) indication device (for ex. bulb) must be connected to the contacts 31 and 33 or 34 and 36 of connection board.

 Remote unit switching on and off is available only when auto mode is set!

2. Ventilation correction in the winter

In wintertime, when heating power is not enough and supply air temperature is below setting value, ventilation intensity automatically is decreasing in one level. If there is not enough, one more level (up to minimum) till set supply air temperature will be maintained.

3. Pump control

Units with water heater are designed with water circulation pump control. In winter pump operates continually, in summer season it is off. When outdoor temperature is lower than 5°C, pump is automatically turned on. Pump is connected to the connection box contacts (see 1.3. chapter).

4. Cooling energy recovery

In summer when room temperature is lower than temperature outside, units with either plate heat exchanger or rotary heat exchanger automatically operate with activated function of cooling energy recovery.

5. Remote unit failure indication

In the connection box (see chapter 1.3.) are provided 29,30 contacts, which are intended for connection of unit's emergency stop indicating device.

2.6. Unit PC control

This is additionally ordered function and for it implementation special network module is provided. It allows monitoring and controlling unit operation, through computer network or Internet. Network module is installed inside the unit and connected to the controller (see unit wiring diagram). Connection diagram is given in the 2.6 Picture when module mounted outside.

2.6 Picture

Network Module Connection Diagram

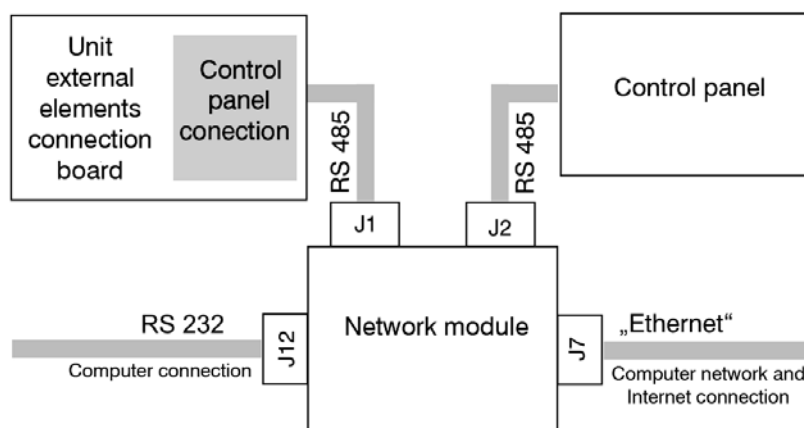

After connecting units through special network modules to computer network or Internet and given an IP address, *Ventilation Control System* visualization program allows the operator from his computer not only to monitor, but also to control air handling units operation: to turn on/off, change ventilation intensity and etc. It also allows indicating failures. Detailed unit computer control description is given in the computer program using instruction.

2.7. Troubleshooting

If the unit is not working:

- Make sure if the unit is connected to the electrical power supply.
- Check if the unit main switch is on, it is located on the unit wall (if designed).
- Check all control block fuses. If needed, change failed fuses with the new ones that are the same electrical parameters as old ones (fuses types are shown in wiring diagrams).
- Check if there is not failure indication on the control panel. If there is indication, it needs to be eliminated first. To eliminate failure use 2.7 Table, which describes failures.
- If nothing is indicating on control panel, check whether cable connecting control panel with the unit is not damaged.

2.7 Table

**Failures indicated on the control panel,
possible reasons and it elimination**

Message	Light Diode	Possible Failure Cause	Failure Elimination
CHANGE SUPPLY AIR FILTER	Red blinking	Supply air filter is clogged.	After unit is off, it is necessary to change filter.
CHANGE EXHAUST AIR FILTER	Red blinking	Exhaust air filter is clogged.	After unit is off, it is necessary to change filter.
SUPPLY AIR LOW TEMPERATURE	Red light	Supply air temperature dropped lower allowable level.	Check program settings, unit heat exchanger and heater operation.
SUPPLY AIR OVERHEATING	Red light	Supply air temperature is higher allowable level.	Check program settings, unit heat exchanger and heater operation.
SUPPLY AIR FAN OVERHEATING	Red light	Supply air fan motor overheated due to excessive load.	Check if air filters are inserted, if the unit doors are closed, if unit ventilation system has been installed correctly.
EXHAUST AIR FAN OVERHEATING	Red light	Exhaust air fan overheated due to excessive load.	Check if air filters are inserted, if the unit doors are closed, if unit ventilation system has been installed correctly.
HEATER OFF	Red blinking	Heater is disconnected due to low air flow.	When heater cools down, protection restores automatically. It is recommended to increase ventilation intensity level.
ELECTRIC HEATER OVERHEATING	Red light	Electric heater overheating protection is on.	To restore protection, it is possible only after pressing "RESET" button, which is located on the heater.

 It is possible to restore emergency overheating protection with button "RESET", only if before heater overheating cause has been clarified and eliminated.

2.7 Table continuation

Message	Light Diode	Possible Failure Cause	Failure Elimination
RETURN WATER LOW TEMPERATURE	Red light	Return water temperature in water heater dropped lower allowable level.	Check circulation pump and heating system condition, heating valve actuator performance.
FROST POSSIBILITY	Red light	Temperature of the air passing through plate heat exchanger, dropped lower allowable level.	Check by-pass damper condition and actuator performance. It is recommended to decrease ventilation level.
ROTOR STOPPING	Red light	The belt is broken, or failure of the rotor motor.	Check rotor drive and rotation sensor condition.
FIRE ALARM	Red light	Received fire alarm signal from the building fire system.	When fire alarm signal disappears, unit needs to be restarted from control panel.
SENSOR FAILURE	Red light	Temperature sensor (s) is not connected or broken down.	It is necessary to check sensors connections or change them.



If the unit has been stopped and there is red light diode signal on the controller, and text message is shown meaning failure, failure needs to be eliminated!



Before performing any jobs inside the unit make sure that the unit is stopped and disconnected from the electrical power supply.

After failure has been eliminated and power supply connected, text message appears about previous failure.

If there are no more failures, unit is switched on by pressing  button; unit continues operating by preset mode. However if the failure has not been eliminated, unit either starts operating and after some time it stops again, or it does not operate and failure message is indicated.

Unit Functional Diagram

KOMPAKT RECU 3000, 4000 Functional Diagram

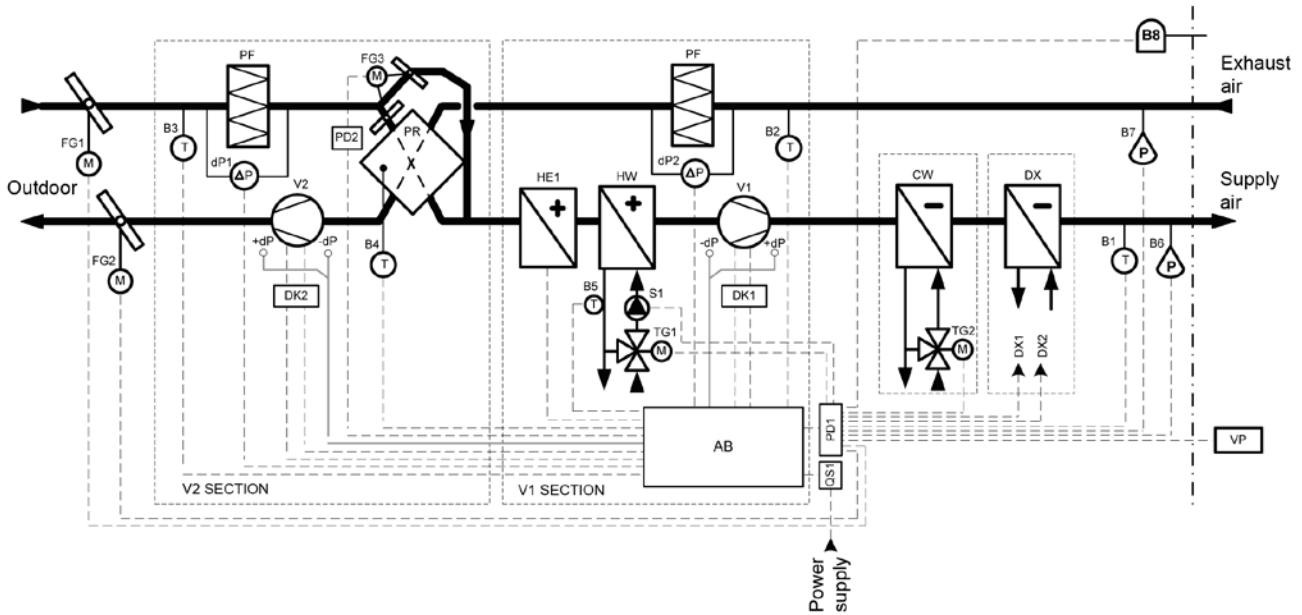

AB	Control box	FG3	By-pass damper actuator
B1	Supply air temperature sensor	HE1	Electric heater
B2	Exhaust air temperature sensor	HE2	Additional electric heater
B3	Outdoor temperature sensor	HW	Water heater
B4	Heat exchanger temperature sensor	PF	Air filter
B5	Return water temperature sensor	PR	Plate heat exchanger
B6, B7	External pressure sensor	PD1, PD2	Connection box
B8	Air quality sensor	QS1	Main switch
CW	Water cooler	S1	Circulation pump
DK1, DK2	Frequency inverter	TG1	Hot water mixing valve actuator
DX1, DX2	DX cooling control	TG2	Cold water mixing valve actuator
dP1, dP2	Pressure switch for filter	V1	Supply air fan
FG1	Supply air damper actuator	V2	Exhaust air fan
FG2	Exhaust air damper actuator	VP	Control panel

Depending on the unit type, various automation system principle solutions are possible. Electrical connection of the particular unit is specified in the principal electric diagram.

Descriptions of used markings in the diagrams are specified in the table.

Table

Specification of the Components

Marking	Description
B2	Exhaust air temperature sensor
B3	Outdoor temperature sensor
B4	Plate heat exchanger temperature sensor
B5.1	Return water temperature sensor
C3	Controller
C3-E1	Electric heater power control board
C3-P1	External connection board
D3S	Intermediate board
dP1	Supply air filter differential pressure switch
dP2	Exhaust air filter differential pressure switch
DK1	Supply air fan motor frequency inverter
DK2	Exhaust air fan motor frequency inverter
EK1, EK2	Electric heater step
F1	The fuse
FG1	Supply air damper actuator
FG2	Exhaust air damper actuator
FG3	By-pass damper actuator
K1, K2, K3	Relay 30A, 230V AC
PD1, PD2	Connection box
QF1, QF2	Automatic switch
SIM1- SIM4	Triac
TF1, TF2	Mains filter
TK1	Electric heater overheating protection 80°C (automatic reset)
TK2	Electric heater overheating protection 120°C (manual reset)
TK3	Triacs overheating protection 70°C (automatic reset)
V1	Supply air fan
V2	Exhaust air fan
X1...X11	Connection between unit parts

KOMPAKT RECU 3000/4000 Wiring Diagram

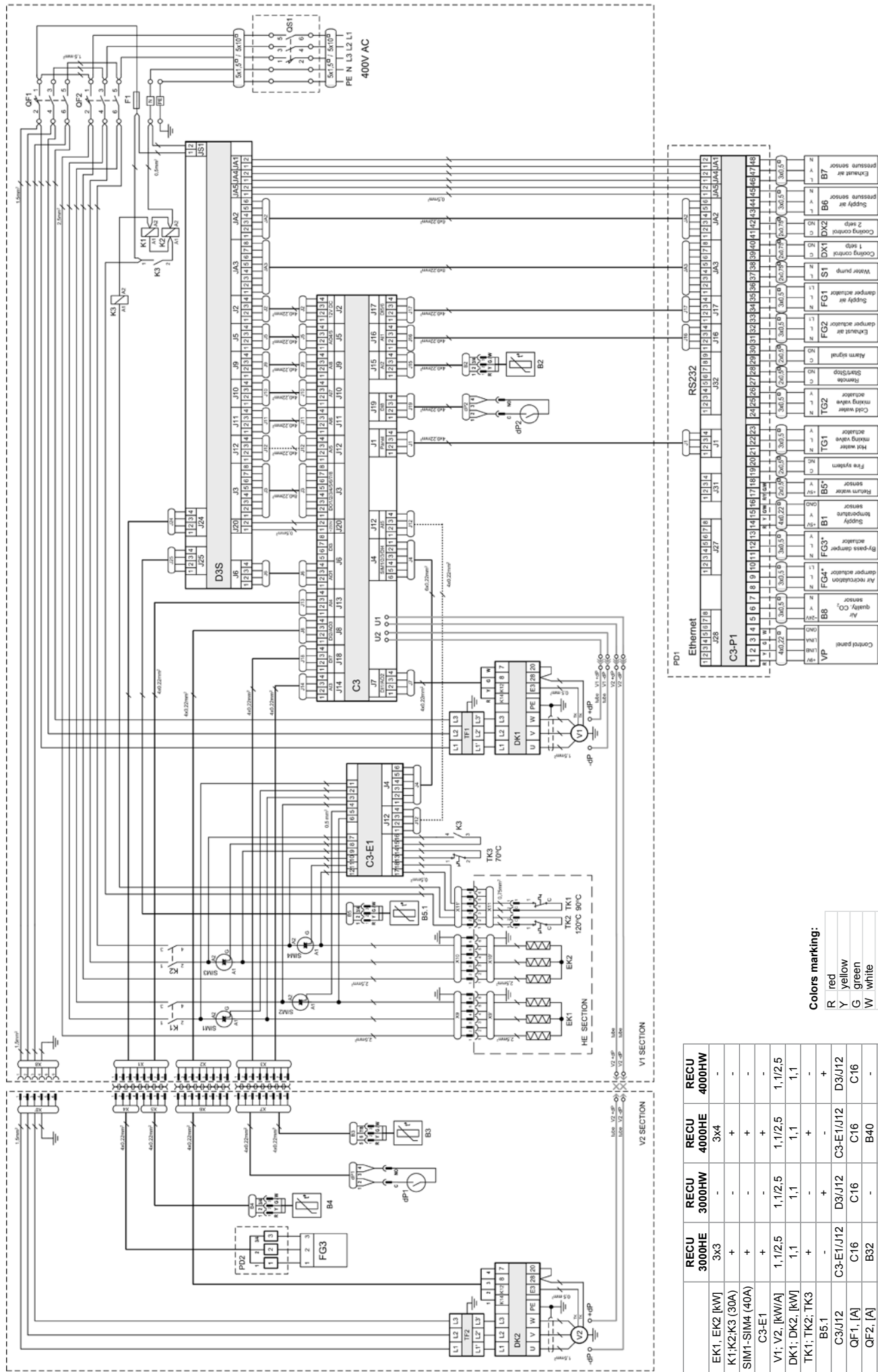

Colors marking:

R	red
Y	yellow
G	green
W	white

Note:
* not used

	RECU 3000HE	RECU 3000HW	RECU 4000HE	RECU 4000HW
EK1, EK2 [kW]	3x3	-	3x4	-
K1;K2;K3 (30A)	+	-	+	-
SIM1-SIM4 (40A)	+	-	+	-
C3-E1	1,1/2,5	1,1/2,5	1,1/2,5	1,1/2,5
V1; V2, [kW/A]	1,1	1,1	1,1	1,1
DK1; DK2, [kW]	-	-	-	-
TK1; TK2; TK3	-	-	-	-
B5.1	-	+	-	+
C3/J12	C3-E1/J12	D3/J12	C9-E1/J12	D3/J12
OF1, [A]	C16	C16	C16	C16
OF2, [A]	B32	-	B40	-
FF1, [A]	FF 1,0	FF 3,15	FF 1,0	FF 3,15
OS1, [A]	40	16	63	16



UAB AMALVA

Ozo str. 10, LT-08200 VILNIUS
e-mail info@amalva.lt
www.amalva.com
www.komfovent.com