

KOMPAKT REGO P

Series Air Handling Unit
Installation and Maintenance Service Manual



This symbol indicates that this product is not to be disposed of with your household waste, according to the WEEE Directive (2002/96/EC) and your national law. This product should be handed over to a designated collection point, or to an authorised collection site for recycling waste electrical and electronic equipment (EEE). Improper handling of this type of waste could have a possible negative impact on the environment and human health due to potentially hazardous substances that are generally associated with EEE. At the same time, your cooperation in the correct disposal of this product will contribute to the effective usage of natural resources. For more information about where you can drop off your waste equipment for recycling, please contact your local city office, waste authority, approved WEEE scheme or your household waste disposal service.



Content

Safety Requirements	4
Transportation	5
Brief Description of the Unit	6
Installation	7
Maintenance	8
Technical Information	9
Ordering Key	9

Safety Requirements



- To avoid accidents and/or unit damage, only a trained technician must carry out the connection.
- The appropriate Personal Protective Equipment (PPE) attire is worn relative to the operation being carried out.
- Electrical equipment is rated, connected and earthed in accordance with CE regulations.

The air handling unit must be plugged in to an electrical outlet (with earth), which is in good order and corresponds with all requirements of electric safety.

Before starting any operations inside the unit, make sure that the unit is switched off, and the power cable is unplugged.



- Earth must be installed according EN61557, BS 7671.
- The unit should be installed according to Installation and Maintenance Manual.
- Before starting the unit, check correct position of air filters.
- Service maintenance should be carried out only in conformity with the instructions specified herein below.

Transportation

The air handling units are ready for transit and storage (1 Picture). The unit is packed to prevent damage of the external and internal parts of the unit, dust and moisture penetration.

Corners of the air handling units are protected against the damage – protective corners are used. The entire unit is wrapped up in protective film. For transit or storage, units are mounted on timber pallets. The unit is fastened to the pallet with polypropylene packing tape over protective corners.

Air handling unit ready for transit and storage

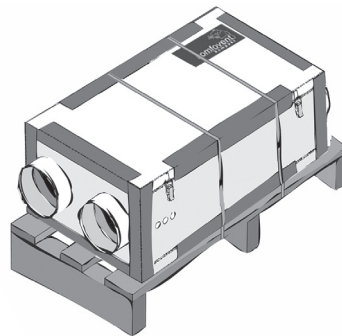

1 Picture

When unit is loaded or unloaded by crane, cargo rope is fastened in its designated places. Forklift truck or hand pallet truck can transport air handling unit as it is shown (2 a,b,c Pictures).

Air handling unit transportation by forklift truck, hand pallet truck or crane

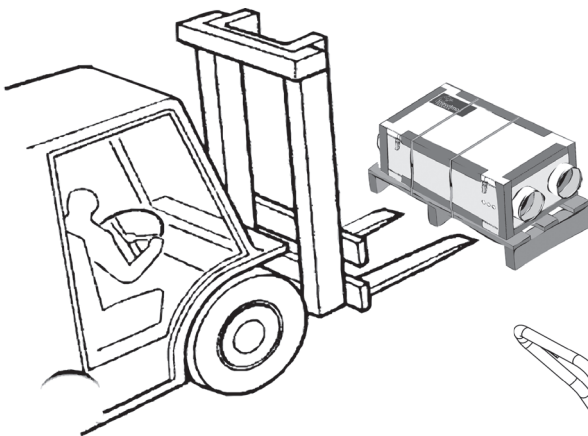

2 a Picture

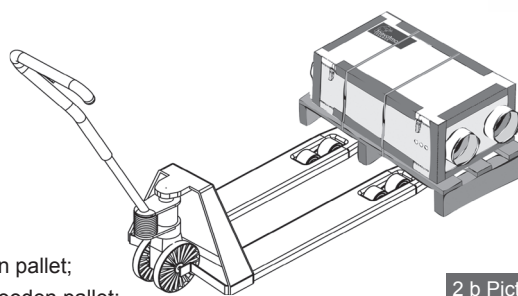

2 b Picture

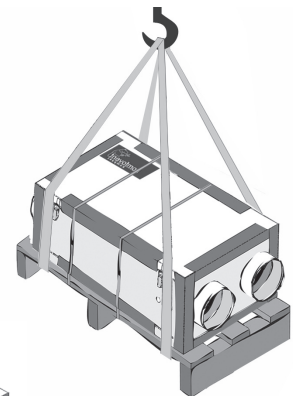

2 c Picture

- 2a Unit is transported by forklift truck on a wooden pallet;
- 2b Unit is transported by hand pallet truck on a wooden pallet;
- 2c Unit is lifted by crane on a wooden pallet.

The unit should be examined upon receipt, to ensure that no visible damage has occurred during transit, and the advice note checked to ensure that all items have been received. If damage or delivery shortages are discovered, the carrier should be immediately informed. AMALVA should be notified within three days of receipt, with a written confirmation sent within seven days. AMALVA can accept no responsibility for damage by unloading from carrier or for subsequent damage on site.

If the unit is not to be installed immediately, it should be stored in a clean, dry area. If stored externally, it should be adequately protected from the weather.

Brief Description of the Unit

Casings of air handling units are made of galvanized steel sheets, which are powder painted. Mineral wool is used for thermal insulation and sound attenuation. Units cover panels are 45 mm thick.

The air handling units are intended for ventilation of small and medium-sized spaces (eg. single family houses, offices, etc.), having operating ambient temperature and relative humidity.

KOMFOVENT KOMPAKT REGO P series units are equipped with a rotary heat exchanger, air filters, an electric air heater, fans and automation control system, to ensure safe and efficient operation of the unit.

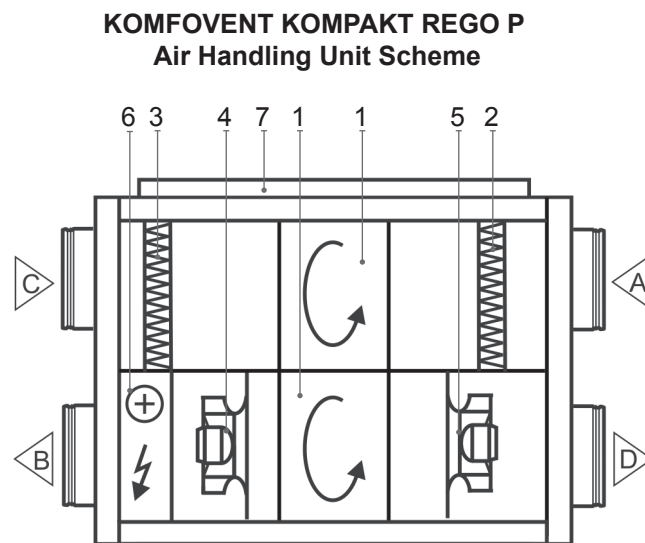

3 Picture

REGO 1200PE

1. Rotary heat exchanger
2. Supply air filter
3. Exhaust air filter
4. Supply fan
5. Exhaust fan
6. Electric air heater
7. Automation control system

- △ A Outdoor intake
- △ B Supply air
- △ C Extract indoor
- △ D Exhaust air

Installation

Maintenance Space Requirements

It is recommended to install the air handling unit in a separate room or in the attic on a hard smooth surface insulated with a rubber mat (4 a Picture). The place for the unit should be selected with allowance for minimum access to the unit for maintenance and service inspection. The minimum free space in front of the control panel should be not less than 600 mm.

Air handling units can be also installed over ceiling or on the wall (see 4 b, c Pictures). To hang unit use vibration dampers. Free access to the unit should be projected in ceiling construction.

Maintenance Space

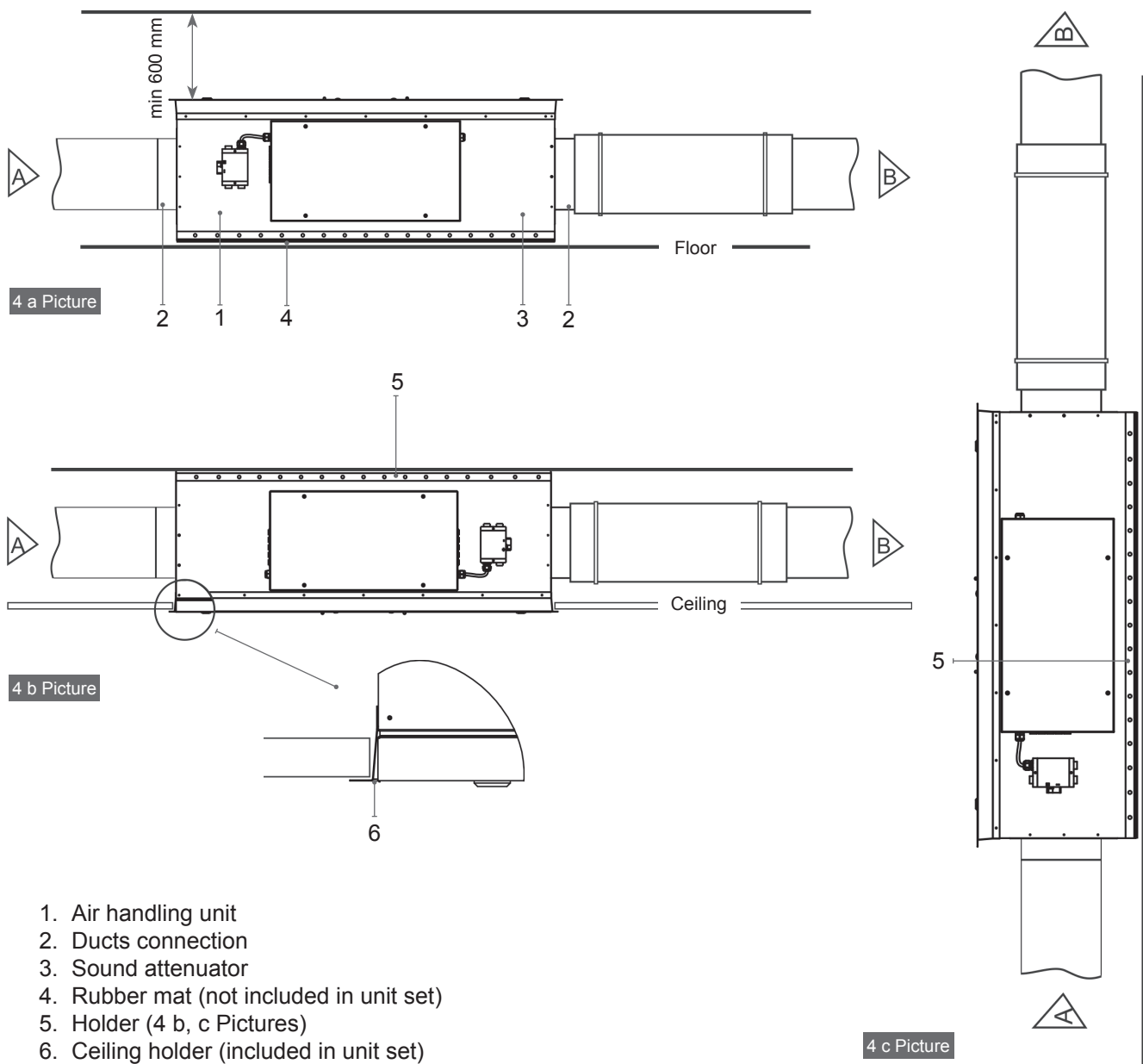

Unit holder is made of 2,5 mm galvanized steel sheets according to EN 10142.

Ductwork

The air flows in/out air handling unit through ductwork. We recommend using galvanized steel (Zn 275 gr/m²) ductwork, to ensure easy cleaning and durability. It is necessary to use the ductwork system with low air flow rate and small pressure drop to have necessary air volume and low sound level and save the energy. The appropriate sound attenuators will reduce the noise level of the fans in the premises.

Outdoor and exhaust ductwork should be insulated with 50–100 mm thickness insulation to avoid the condensation.

Note: temperature sensor B1 has to be mounted in the supply air duct under electric heater (see the functional diagram in Control System Installation and Operation Manual). It is necessary to leave space in straight air duct for sensor mounting and guarantee the space for maintenance and service work. Minimal space between the unit and B1 sensor is the space of double air duct diameter.



Ductwork, steelwork and any other services should not be supported off the unit.

Final Inspection

After installation of the unit, a thorough inspection should be carried out. This should include inspecting the inside of the unit and removing debris and tools, which may have been left behind by on site contractors. Replace any panels, which may have been removed and close all access doors, ensuring that the door sealing gaskets have not been damaged.

Maintenance

It is recommended to carry out routine maintenance of the air handling unit KOMFOVENT KOMPAKT REGO P 3 – 4 times per year.

Use the key to open the door. Do not release the door to swing freely, but open it slowly at a 90 degree angle. Be careful while opening, because clogged filters might fall out.

Besides preventive maintenance inspection, the following operations should be performed:

- 1. Rotary heat exchanger check.** Inspection of the rotary heat exchanger is performed once per year. Free rotation of the rotary heat exchanger, continuity of the rotating belt, absence of damages of the rotor drums and the seal gasket are checked. It is necessary to check the stretch of belt. Free belt will slide and the efficiency of rotary heat exchanger will fall down. To reach maximal efficiency, rotor must turn at least 8 times per minute. Polluted heat exchanger will decrease efficiency. Clean heat exchanger with an air blast or wash with tepid water. Check out water falling on the electric motor.
- 2. Fans check** (once per year). Polluted fans decrease efficiency.



Before performing any inspection work, check whether the unit is switched off from the electric power supply.

Fans should be carefully cleaned with textile or soft brush. Do not use water. Do not break balance. Check if fan freely rotates and is not mechanically damaged, if impeller does not touch suction nozzles, fan does not spread noise, the pressure tubes are connected to the nozzle (if it is required), mounting bolts are screwed.

The rubber couplings connecting the motor base and the unit should be visually inspected for signs of wear and replaced as necessary.

Any unusual noise or vibration when the fan is running should be immediately investigated, as this usually an indication of wear or imbalance in the fan system.

3. Air heater check. Check if electric air heater is properly fixed, wires connections are not damaged and heating elements are not bent. They can be damaged or bent due to uneven heat or uneven and turbulent air direction. Check if electric air heater is clear of unnecessary things and heating elements are not clogged, because this can cause unpleasant smell or in the worst case – dust can start burning. Air flow through the air heater should be greater than 1,5 m/s. Heating elements can be cleaned with Hoover or wet textile.

4. Air filter clogging check. Change air filters when air filter clogging is indicated. We recommend to change filters at least twice per year: before and after heating season, or more*.

If air handling unit is working in small speed, the filters must be checked on unit maximum speed. Filters are one time used. We do not recommend cleaning them. Stop the air handling unit before changing filters.

* *Clogged filters unbalance ventilation system, air handling unit uses more power.*

Technical Information

Type	Weight	Supply voltage	Operating current	Heater capacity	Fans input power	Ducts connection	Filter class (Supply/Exhaust air)	Filter type	Dimensions
REGO	kg	V	A	kW	W	mm			bxhxl, mm
1200 P	120	3x400	8,7	4,0	2x425	315	F5/F7	Panel	410x420x46

Scheme

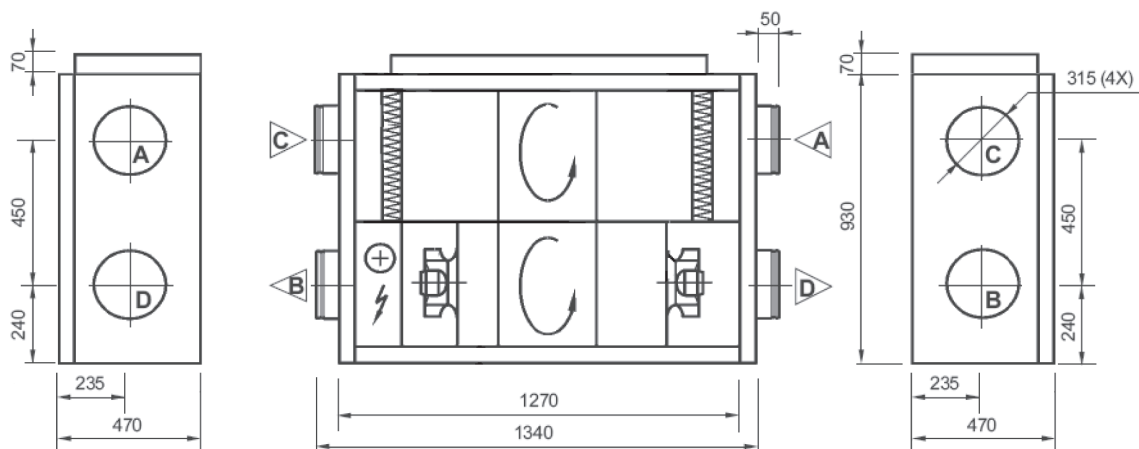

Ordering Key

REGO 1200 P E - EC - C3 - F

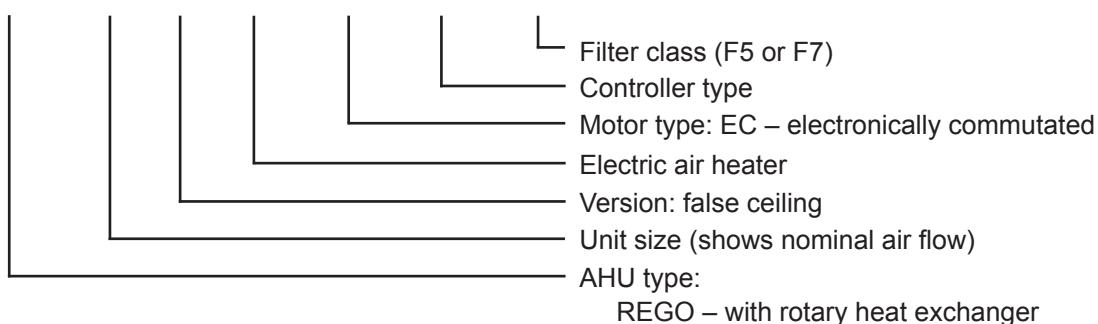



Limited Warranty Coupon

komfovent[®]
kompakt

The seller fills up

Stick the label here

Quality control performed by:		Stamp
Signature		
Warranty term	24 months*	
Date of purchasing		
<i>The customer fills up</i>		
Complete and ready for use product with the manual instruction for it was got. I became acquainted with the warranty conditions and accept them:		
Customer signature		
<small>*refer to "Warranty conditions"</small>		

Dear purchaser,

Company AMALVA thanks you for your choice. Especially big attention is paid to the quality of the equipment; therefore we would appreciate all your comments and offers concerning technical and operational features of the equipment.

In case of occurrence of any problems we recommend to contact immediately the nearest AMALVA branch office, or to turn to your service company which performed installation, commissioning or technical maintenance works. Address and telephone number is indicated in the warranty coupon.

In order to prevent misunderstanding we ask to acquaint closely with the equipment manual instruction and to check up correctness of filling up the warranty coupon. Unit serial number printed on the metal label fastened to the unit must correspond to that one specified in the warranty coupon.

The warranty coupon is valid only if the model of the equipment, its serial number, date of sale is correctly specified in it; safety sticker of electrical connection box is not damaged; there are precise stamps of the purchaser and the customer's signature. It is forbidden by any way to change, erase or copy the data specified in the warranty coupon - such coupon will be considered void.

By this warranty coupon, Company AMALVA applies the undertakings to implement the requirements of the customers in conformity with THE LAW ON CONSUMERS PROTECTION in case of discovering the defects of the products. Company AMALVA reserves the right to refuse rendering free-of-charge services on warranty service if the warranty conditions specified further are not observed.

Warranty conditions

1. The warranty period of quality of the equipment established by the manufacturer - from the date of purchase of a product. If the purchasing date is not filled in the coupon, then manufacture date is considered to be that date.
2. The warranty is not given:
 - a) if customer can not submit properly and completely filled up warranty coupon;
 - b) if damage occurred or repairs required as a consequence of improper shipping or handling, faulty installation, improper servicing;
 - c) if there are the attributes testifying to attempts to execute unqualified repair;
 - d) in case of detection of equipment construction alteration, not corresponding to requirements of the manufacturer;
 - e) if the equipment is used not according to its direct purpose;
 - f) if serial number indicated on metal label fixed to the equipment is changed or destroyed and is impossible to restore.
3. The guarantee is not given in the following cases of malfunction of the equipment:
 - a) at presence of mechanical damages;
 - b) at presence of damages which reason is hit inside of a product of extraneous subjects, materials, liquids;
 - c) at presence of damages due to floods, winds, fires, lightning, corrosive environments, accidents or other casual external impact, etc.
4. The warranty does not cover normal maintenance as outlined in the manual instruction including cleaning, filters or fuses changing, etc.
5. Company does not bear the responsibility for the direct or indirect damage made to people, pets or properties, if the reason of such damage - non-observance of rules and conditions of use and installation of equipment, wilful damage or careless behaviour of the users or the third parties.



UAB AMALVA

Ozo str. 10,
LT-08200 VILNIUS, LITHUANIA
e-mail info@amalva.lt
www.amalva.com
www.komfovent.com