

CI/SfB

(57.7)

1st edition

Compact MVHR & Cooker Hood Unit



Lo-Carbon Sentinel Kinetic

**Vent-Axia<sup>®</sup>**  
**Lo-Carbon<sup>™</sup>**



By Appointment to H.M. The Queen  
Suppliers of Unit Ventilation Equipment  
Vent-Axia, Crawley, West Sussex

# Vent-Axia®

## VENT-AXIA CONTACT NUMBERS

Free technical, installation and sales advice is available

### Sales Centre: Domestic & Commercial

Sales Tel: 0844 856 0590  
Sales Fax: 01293 565169  
Tech Support Tel: 0844 856 0594  
Tech Support Fax: 01293 539209

### Industrial

Sales Tel: 0844 856 0591  
Sales Fax: 01293 534898  
Tech Support Tel: 0844 856 0595  
Tech Support Fax: 01293 455197  
**Web:** [www.vent-axia.com](http://www.vent-axia.com)  
**Email:** [info@vent-axia.com](mailto:info@vent-axia.com)

### Supply & Service

All sales made by Vent-Axia Limited are made only upon the terms of the Company's Conditions of Sale, a copy of which may be obtained on request. As part of the policy of continuous product improvement Vent-Axia reserves the right to alter specifications without notice.



A British company supporting British manufacturing  
**Vent-Axia Ltd t: 0844 856 0590** Right products, right price, right here!

402192/0609

# Vent-Axia Sentinel<sup>®</sup> Kinetic

## Mechanical Ventilation with Heat Recovery

Lo-Carbon Energy saving Ventilation solutions

### Features and Benefits

- **Manufactured in the UK**
- Building Regulations Part F compliant
- SAP Appendix Q Eligible
- Energy savings trust best practice compliant
- Up to **92% heat recovery** whilst controlling condensation
- Optional, programmable Summer bypass
- Cooker Hood version available
- Left or right hand installation
- Horizontal and/or vertical duct outlets
- Integrated digital controller for simple and accurate commissioning
- Light weight for easy installation
- External condensate connection
- Plug and play controls; Humidistat, Vent-Wise, Wireless remote
- BMS connectivity
- LS inputs. (Light switch)
- Volt-free inputs
- Self diagnosis for simplified fault finding
- Multiple switching options: Light switch, PIR, Humidistat etc
- Adjustable delay on/delay off timer
- Easy access G3 filters
- Compact size - fits in a 600mm x 300mm kitchen cupboard



# Sentinel Kinetic

# Vent-Axia Sentinel<sup>®</sup> Kinetic

## Wholehouse Heat Recovery Ventilation System

The Sentinel Kinetic incorporates:

A wholehouse heat recovery system with up to 92% energy efficiency. An easily accessible heat recovery cube protected by two removable EU3 filters. Two Lo-Carbon Energy Saving EC DC fans ensure long life (typically over double the life of AC motors) and lowest possible energy use. Fully insulated construction with built in condensation drain. Fitted with 125mm spigots. Specifically designed for new build homes with a high level of insulation.

Lo-Carbon Sentinel Kinetic **meets the latest requirements of the Building Regulations Document F 2006** for wholehouse system ventilation: System 4. Continuous mechanical supply and extract with heat recovery. The Lo-Carbon Sentinel Kinetic models have 2 fully adjustable speeds and a purge setting - maximum. On the front of the unit is a digital controller that can be used to pre-set the speeds to any required air-flow within the performance range.

### Options

The integral humidity sensor increases speed in proportion to relative humidity levels, saving energy and reducing noise.

The sensor also reacts to small but rapid increases in humidity, even if the normal trigger threshold is not reached. This unique feature ensures adequate ventilation, even for the smallest wetroom.

Night time relative humidity setback feature suppresses nuisance tripping as humidity gradually increases with falling temperature.

Acoustically lined - low noise levels from only 20dB(A) @3m

### SAP Appendix Q Performance

	Specific Fan Power (W/l/s)	Thermal Efficiency
K+1	0.72	92%
K+2	0.74	91%
K+3	0.81	90%
K+4	0.93	88%
K+5	1.07	87%



### Model

- Kinetic V (non-summer bypass)
- Kinetic B (with summer bypass)
- Kinetic CW L (with white Cooker Hood)
- Kinetic CS L (with Brushed Aluminium Cookerhood)
- Kinetic CW R (with white Cooker Hood)
- Kinetic CS R (with Brushed Aluminium Cookerhood)

### Stock Ref

- 438342**
- 438222**
- 441483**
- 441484**
- 441485**
- 441486**

### Optional Controls

- Internal humidity sensor
- Wireless enable kit
- Vent-Wise Controller
- Additional wireless switch (max 4 switches)

- 441838**
- 441865**
- 441780**
- 437826**

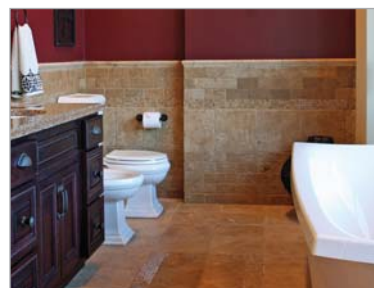

## Your Carbon Footprint

The Carbon Footprint is a measure of the amount of carbon dioxide (CO<sub>2</sub>) emitted through the burning of fossil fuels. From a residential and commercial building perspective, it is the amount of carbon generated when you produce a kilowatt of electricity. Reducing a building's carbon footprint will ultimately reduce electricity bills and save money for every individual household or business. It will also help meet the UK target for the reduction of emissions, as well as allowing you to protect the environment.



- allowing you to help the environment by reducing your

## Performance

Fan speeds are fully adjustable within the performance range

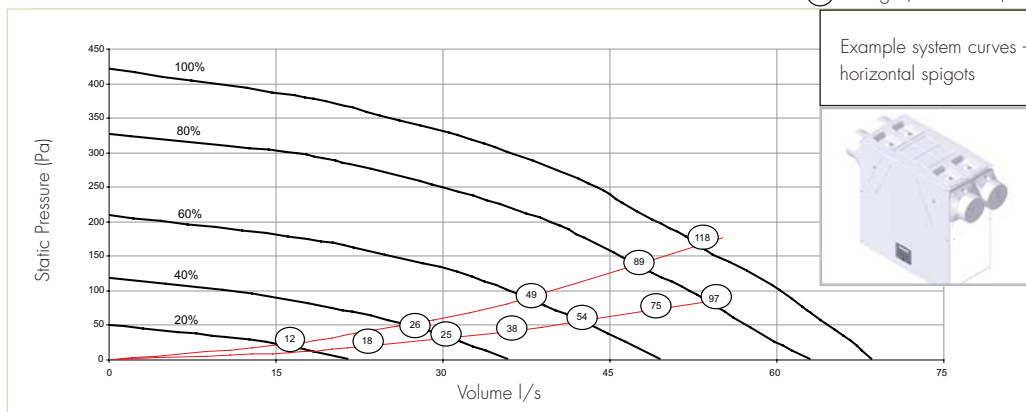
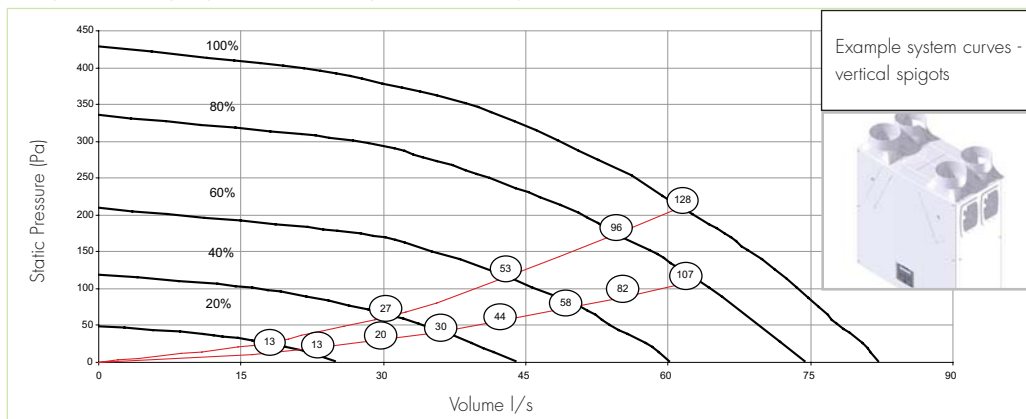

(X) wattage (both motors)

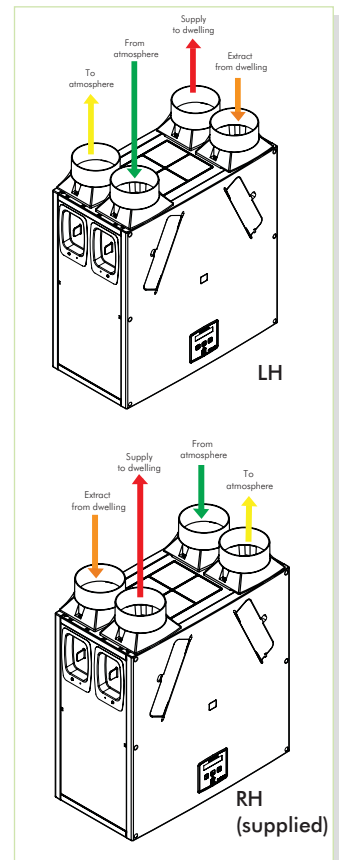

## Sound Data

Flow, l/s	Test mode	Octave band, Hz, dB SWL								SPL dBA@ 3m
		63	125	250	500	1K	2K	4K	8K	
10	Supply	47.8	40.2	38.0	31.1	28.2	22.1	23.6	30.9	21.4
	Extract	47.0	38.7	36.0	29.9	25.0	22.4	23.3	30.8	20.6
	Breakout	43.6	36.2	37.4	30.9	27.4	23.3	24.2	31.4	18.6
20	Supply	54.0	46.6	50.2	44.5	44.4	38.3	28.8	31.9	31.2
	Extract	46.8	40.5	34.6	34.2	34.6	25.9	23.7	30.3	22.9
	Breakout	45.9	39.9	40.6	35.7	33.5	28.4	25.3	31.2	21.3
30	Supply	58.1	54.5	57.6	52.2	51.7	47.6	38.6	35.8	38.5
	Extract	47.6	46.2	38.7	41.3	42.8	33.9	26.4	30.5	28.4
	Breakout	45.2	42.4	48.2	40.8	37.7	35.2	30.0	31.1	25.2
40	Supply	65.2	58.4	62.3	58.0	56.5	52.5	44.1	41.4	43.6
	Extract	53.5	53.0	44.0	47.7	48.1	39.7	31.5	31.5	33.5
	Breakout	50.9	47.6	47.4	48.1	42.5	40.8	36.3	34.4	29.3
50	Supply	66.4	63.2	66.3	62.5	61.7	57.4	50.0	47.8	48.3
	Extract	64.2	55.2	48.0	50.9	52.1	44.5	35.9	35.0	37.2
	Breakout	55.0	51.0	51.3	51.6	46.9	46.0	42.0	38.3	33.2

Tested according to BS848. Breakout quoted spherical, Supply and Extract quoted hemispherical.

# Vent-Axia Sentinel® Kinetic

## Wholehouse Heat Recovery Ventilation System

our carbon footprint

### Dimensions (mm)

#### CW & CS models (Cooker Hoods)

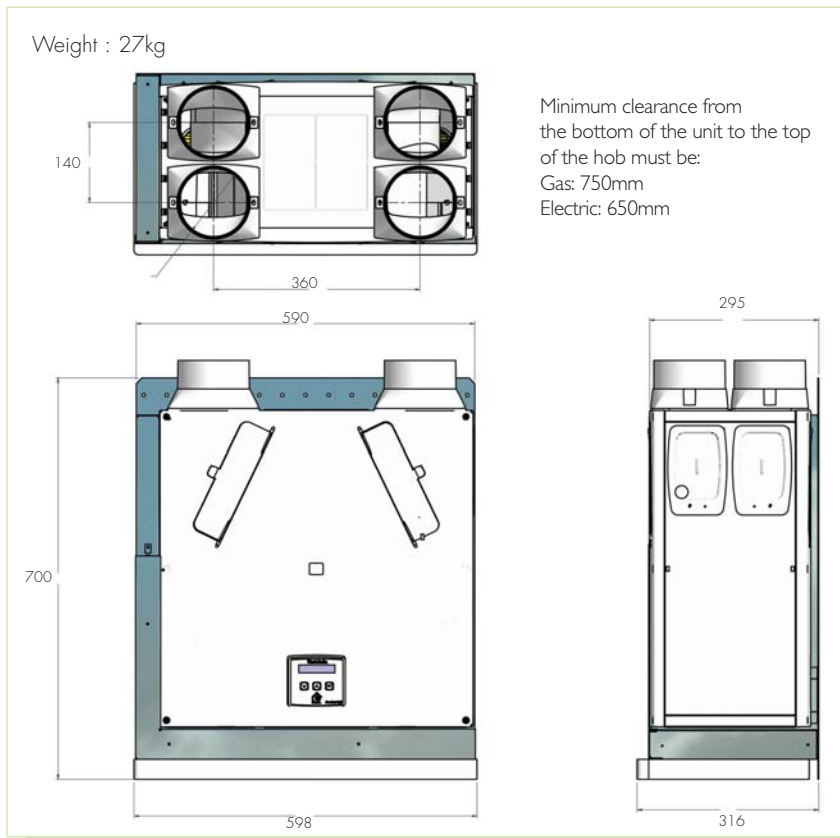

#### V&B models

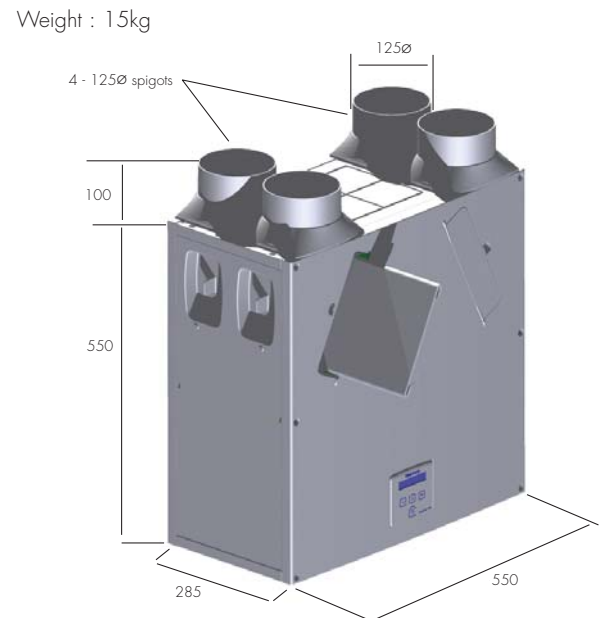

### Easy Installation

The Sentinel Kinetic models can be mounted vertically in a roof space, and are suitable for wall mounting or within a kitchen cupboard. When mounted in an unheated area ducting should be insulated. Ducting can be attached to the unit horizontally, vertically or both. Minimum internal depth of kitchen cupboard: V&B models 290mm. CW models 300mm

Left or right hand installation. The unit is supplied with duct spigots to outside on the right hand side. These can be reversed onsite by simply removing the control panel, rotating the unit 180 degrees and re-attaching the control panel.

Horizontal and vertical spigots: The combination of spigot options allows installation in confined locations. If vertical and horizontal connection is required on the same outlet/inlet, additional spigots can be supplied.

Condensate drain can be taken out through the back, bottom or front of the unit. Using the fittings supplied, the final condensate connection is made outside the unit and can be completed after installation.

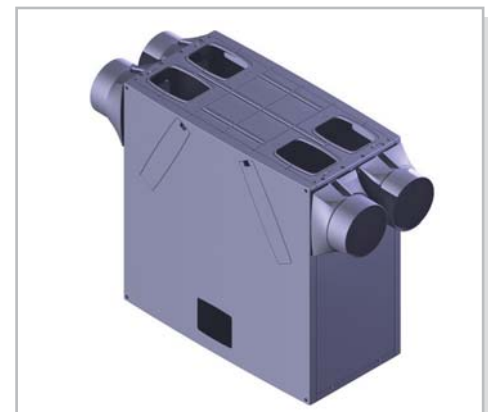

# Vent-Axia Sentinel® Kinetic

## Technical Features

### Multiple control options:

Five Volt-free pairs of switch terminals for sensor inputs allow boosting from a full range of Vent-Axia controllers – Humidistats, PIR, timers.

Two terminals with 0-24V outputs allow 0V to 10V proportional control of sophisticated controllers such as CO<sub>2</sub> sensors and proportional humidistats.

The optional Vent-Wise controller senses temperature rise in a bath/shower hot water supply and/or current in a cooker/hob electrical circuit to activate boost, ensuring additional ventilation when needed.

Switched-live for boosting via light switches (220-240 V AC) or manual Normal/Boost switches. This connection has the advantage of Delay-On and Delay-Off facility. Delay-On enables you to prevent the Boost airflow between 0 and 10 minutes, after a light switch has been activated. Delay-Off allows the Boost airflow to continue after a light switch is turned off to ensure effective clearance of humidity. This timer is adjustable between 0 and 25 minutes.

### Purge setting:

The unit can be set to maximum flow (100%) by pressing and holding the Boost button on the unit itself or optional wireless controller for 5 seconds. Purge will continue for two hours unless cancelled by pressing the Boost button again.

### Summer Bypass option:

An internal damper is activated when the outside temperature is

less than the room temperature. The damper opens allowing cooler fresh air to bypass the Heat Recovery Cell and reduce the internal temperature towards the pre-set 'Comfort Temperature'. When the inside air temperature reaches the pre set 'Comfort temperature' the bypass damper closes.

Anti-frost protection: In cold climates there is a possibility of frost building up on the intake side of the heat exchanger. In order to prevent damage, the Kinetic reduces supply flow while maintaining extract flow at temperatures below 0°C.

### Cooker Hood Unit

The Sentinel Kinetic Cooker Hood is designed to fit in a 600mm aperture above a hob. The telescopic hood incorporates two flat removable metal grease filters, low energy light bulbs and is available with white or Brushed Aluminium front trim. The hood contains an integral fire damper in accordance with BRE Digest 398 and is connected to the heat recovery unit by a galvanised steel duct with access for cleaning. When the hood is opened, the heat recovery unit goes to boost speed and the summer bypass automatically opens to prevent cooking by-products entering the heat recovery cell. As an additional safety feature, the duct also contains a thermal switch which turns off the MVHR unit in the event of excessive temperature in the airway. Cooker hood units cannot be handed on-site and must be purchased as left hand or right hand models.

### Cooker Hood System range

System canopy hoods are a motorless hood with extract being provided by the MVHR unit. When the boost button on the canopy is activated, the MVHR unit goes to boost setting and the summer bypass opens preventing cooking by-products entering the heat exchanger cell.

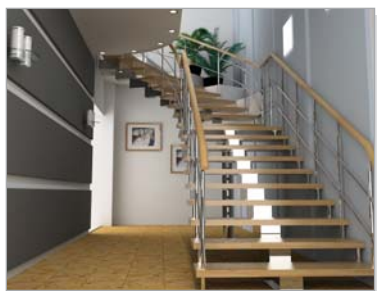

# Vent-Axia Sentinel<sup>®</sup> Kinetic

## Technical Features

### User Benefits

- Compact size means more cupboard space
- Delay-on timer prevents unnecessary boosting
- Delay-off timer ensures effective moisture removal
- 100% Summer bypass option takes advantage of free cooling
- Integrated cooker hood models maximise use of space in compact kitchens
- Very low energy consumption for low running costs and reduced carbon footprint Lo-Watt DC motor with 5 year warranty for years of trouble free use Very low noise levels
- Easy access filters and cleaning reminder
- Open flue setting ensures safe ventilation when used with an open flue heating appliance
- Heat Recovery 92% thermal efficiency.

### Installer Benefits

- Light weight for easier installation (V&B models 15kg)
- External condensate connection supplied for simplified 2nd fix
- Internal humidistat and wireless control options for simplified 1st fix - negates control wiring.
- Horizontal duct option for space saving installations
- Integrated digital controller for accurate commissioning
- Left or right hand fitting reduces duct installation time
- V&B models fit within a 290mm deep kitchen cupboard
- Cooker hood models fit within a 600mm wide aperture (300mm deep)
- Multiple control options; Switched live, (LS) 0 – 10V, Vent-Wise, 24V DC, Volt Free contacts
- Supplied with 2m Flying lead
- Supplied with easy-fit wall brackets

### Developers and Landlord Benefits

- SAP Appendix Q eligible
- Building Regulations Part F compliant
- Clean Filter indicator
- PIN number lock on Commissioning menu
- 7 day dry-out setting
- Running time duration indicator
- Fault code indicator and Service number
- BMS input and output
- Reduces DER's to assist with code for sustainable homes compliance.

