

# Sentinel

## Totus D-ERV

Installation, Operation & Maintenance



### Stock Ref. N°

SENTMINI, SENTMINI/CP,  
SENTMIDI, SENTMINI/CP,  
SENTMAXI, SENTMAXI/CP

***Vent-Axia***®

PLEASE RETAIN THESE INSTRUCTIONS WITH THE PRODUCT.



## IMPORTANT



**PLEASE READ THESE INSTRUCTIONS CAREFULLY BEFORE COMMENCING INSTALLATION AND LEAVE THEM WITH THE END USER.**

1. THESE UNITS MUST BE SITED AND CONNECTED IN ACCORDANCE WITH CURRENT IEE REGULATIONS, BS7671 (UK) OR THE APPROPRIATE STANDARDS IN YOUR COUNTRY.
2. INSTALLATION SHOULD BE BY A QUALIFIED ELECTRICIAN AND INSTALLER.
3. ALL REGULATIONS AND REQUIREMENTS MUST BE STRICTLY FOLLOWED TO PREVENT HAZARDS TO LIFE AND PROPERTY, BOTH DURING AND AFTER INSTALLATION, AND DURING ANY SUBSEQUENT SERVICING AND MAINTENANCE.
4. THESE UNITS MUST BE EARTHED.
5. SITE THE UNIT AWAY FROM DIRECT SOURCES OF HEAT. AMBIENT TEMPERATURE RANGE 10 TO 40°C.
6. WHEN INSTALLING UNIT, TAKE CARE NOT TO DAMAGE ELECTRICAL OR OTHER HIDDEN UTILITIES.
7. CHECK THE DETAILS ON THE RATING LABEL FOR CORRECT VOLTAGE AND ELECTRICAL RATING.
8. THE INSTALLER IS RESPONSIBLE FOR THE INSTALLATION AND ELECTRICAL CONNECTION OF THE SENTINEL SYSTEM ON SITE. IT IS THE RESPONSIBILITY OF THE INSTALLER TO ENSURE THAT THE EQUIPMENT IS SAFELY AND SECURELY INSTALLED AND LEFT ONLY WHEN MECHANICALLY AND ELECTRICALLY SAFE.
9. DUE TO THE WEIGHT OF THE UNITS, IT IS RECOMMENDED THAT MULTIPLE PERSONS ARE INVOLVED IN THE INSTALLATION. AT ALL TIMES, INSTALLATION PRACTICES MUST COMPLY WITH RELEVANT HEALTH AND SAFETY LEGISLATION.
10. SENTINEL AIR HANDLING UNITS ARE DESIGNED AND SPECIFIED FOR USE WITH VENT-AXIA CONTROLS, DAMPERS, GRILLES AND ACCESSORIES.
11. THIS APPLIANCE IS NOT INTENDED FOR USE BY YOUNG CHILDREN OR INFIRM PERSONS WITHOUT SUPERVISION.
12. YOUNG CHILDREN SHOULD BE SUPERVISED TO ENSURE THAT THEY DO NOT PLAY WITH THE APPLIANCE.
13. PRECAUTIONS MUST BE TAKEN TO AVOID THE BACKFLOW OF GASES INTO THE ROOM, FROM THE OPEN FLUE OF GAS OR OTHER FUEL BURNING APPLIANCES.

## PRODUCTS COVERED

**Thank you** for purchasing Sentinel Totus D-ERV.

This document describes the installation and commissioning of your equipment to help get your equipment up and running. It also provides essential maintenance and troubleshooting information to assist the operation and prolong the lifetime of your equipment.

This document covers the Sentinel Totus D-ERV series detailed in the following table.

*Table 1: Products Covered by this Document*

Model Number	Description
SENTMINI	Mini
SENTMIDI	Midi
SENTMAXI	Maxi
SENTMINI/CP	Mini / Constant Pressure
SENTMIDI/CP	Midi / Constant Pressure
SENTMAXI/CP	Maxi / Constant Pressure

See *Technical Specification* for details of these models.

# About this Document

## CONTENTS

<b>Product Description</b>	<b>4</b>
Sentinel Totus D-ERV .....	4
<b>Technical Specification</b>	<b>5</b>
Sentinel Totus Technical Specification .....	5
Commissioning Record .....	5
Dimensions.....	6
<b>Installation</b>	<b>7</b>
Installing Your Energy Recovery Ventilation System .....	7
Before Installation Your Equipment.....	8
Physical Installation.....	9
Electrical Installation.....	11
Switching On .....	14
Switching Off .....	15
<b>Commissioning</b>	<b>16</b>
Commissioning Your Energy Recovery Ventilation System.....	16
Commissioning Interface Screens .....	18
Commissioning Screens.....	19
The Settings Code.....	25
Writing Down the Settings Code .....	26
Default Settings .....	26
<b>Operation and Monitoring</b>	<b>27</b>
About Operation and Monitoring .....	27
Status Monitoring Screens .....	27
<b>Maintenance</b>	<b>30</b>
Caring for Your Unit.....	30
3-Monthly Maintenance .....	30
12-Monthly Maintenance .....	30
5-Yearly Maintenance .....	30
<b>Troubleshooting</b>	<b>31</b>
Diagnosing a Problem .....	31
Diagnostic Codes .....	31
Fault LED/Status Relay .....	32
Power Supply Troubleshooting .....	32
Airflow/Temperature Troubleshooting .....	33
Condensate Troubleshooting .....	34
<b>Appendix A: Glossary</b>	<b>35</b>
Terms and Abbreviations .....	35
<b>Appendix B: Options and Accessories</b>	<b>36</b>
Sentinel Totus .....	36
<b>Appendix C: Main Controller PCB Terminals</b>	<b>37</b>
Terminals.....	37

## Product Description

### Sentinel Totus D-ERV

**Sentinel Totus Demand Energy Recovery Ventilation (D-ERV)** is a heat recovery demand ventilation system designed to meet modern building management and control principles.

Employing a range of sensors to manage the system, demand is typically sensed by PIR, temperature, humidity, air quality, carbon dioxide sensors or other types of Vent-Axia proprietary sensors (see *Appendix B: Options and Accessories on page 36* for details). It can respond to the ventilation requirements of a room by providing airflow only when it is required and at the level that is required, using only the energy that is needed, while recovering maximum energy from the extracted air and transferring it to the fresh supply air. This overcomes many of the drawbacks encountered with traditional fixed volume ventilation systems, which operate irrespective of the occupancy of the room, leading to over ventilation and a wasteful use of energy.

### Models

Three basic models are available:

- **Mini** designed to operate at airflows of up to 700 m<sup>3</sup>/hr.
- **Midi** designed to operate at airflows of up to 1000 m<sup>3</sup>/hr.
- **Maxi** designed to operate at airflows of up to 2000 m<sup>3</sup>/hr.

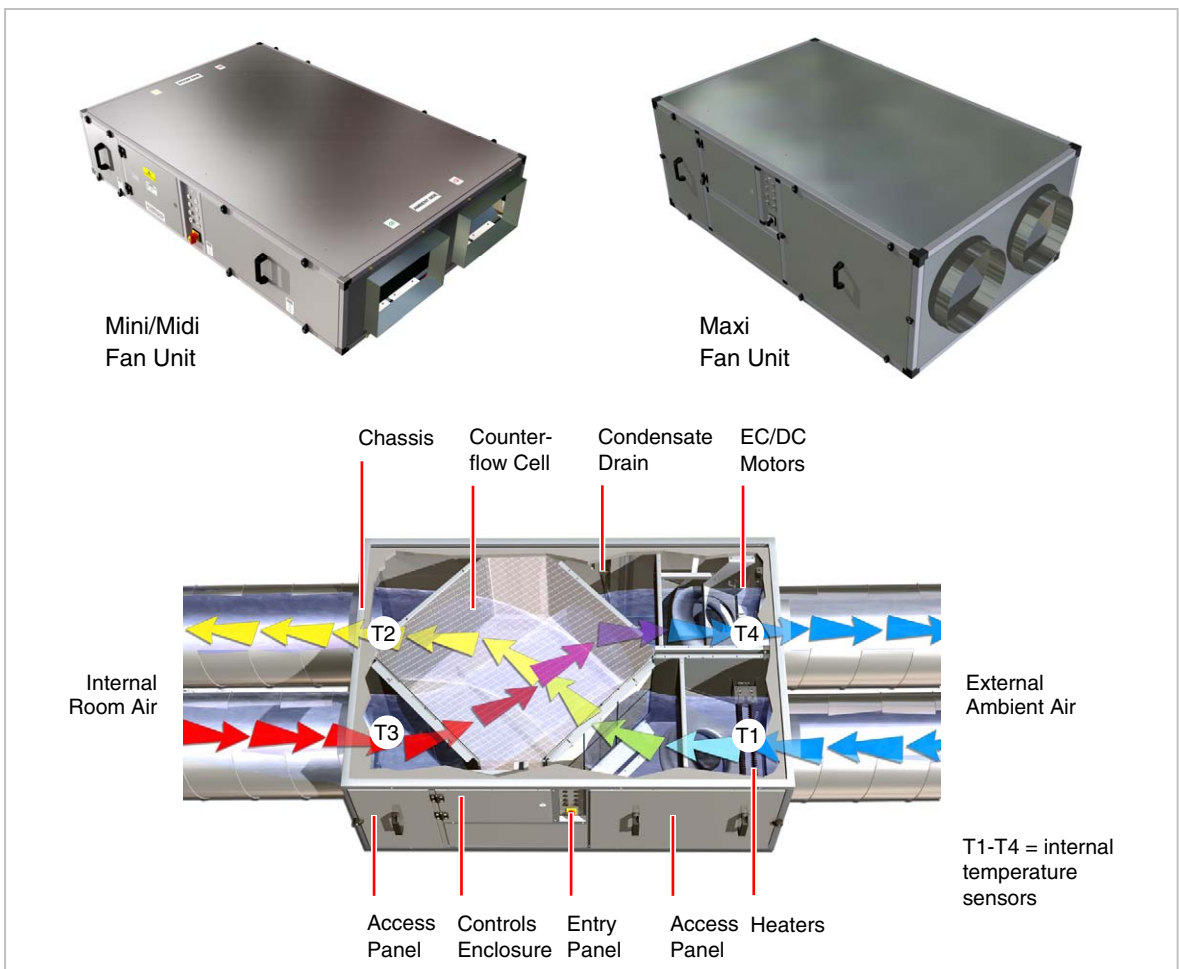

Figure 1: Sentinel Totus

## Technical Specification

### Sentinel Totus Technical Specification

Performance	Mini	Midi	Maxi
Airflow (nominal)	700 m <sup>3</sup> /hr	1000 m <sup>3</sup> /hr	2000 m <sup>3</sup> /hr
<b>Power</b>			
AC Voltage Input	220-240 V ac (single phase)		
AC Frequency Input	50/60 Hz nominal		
Supply Fuse or Cct Breaker	16 A	16 A	32 A
Rated Current	12 A	12 A	20 A
Rated Power	3000 W	3000 W	5000 W
Total Fan Power (max.)	800 W	800 W	1000 W
Total Frost Heater (max.)	2 kW	2 kW	4 kW
Power (standby)	0.6 W	0.6 W	0.6 W
DC Voltage Output	24 V dc (18-30 V dc) at 350 mA (max.) for switches and sensors		
Battery	<i>See Table 6: 5 12-Monthly Maintenance on page 30</i>		
<b>Product Fuses</b>			
Power PCB	<i>See Table 11: Internal Fuse Values and Types on page 33</i>		
Main Controller PCB	<i>See Table 11: Internal Fuse Values and Types on page 33</i>		
<b>Physical</b>			
Height/ Width/ Depth	<i>See Figure 2: Unit Dimensions on page 6</i>		
Weight	145 kg	145 kg	250 kg
<b>Environmental</b>			
IP Rating - Unit	IPX4		
IP Rating - Comm Interface	IP42		
Operating Temperature	-10°C to +40°C		
Air Intake Temperature	-7°C (minimum) to +30°C (maximum)		
Operating Humidity	0% to 95% (non-condensing) – weatherproof unit option		
Storage Temperature	-10°C to +40°C		
Storage Humidity	0% to 95% (non-condensing)		
Condensate Pump	12 m max head, 25 m max horizontal distance, but 150 max head X distance		

For all other technical details, please see the Product Catalogue or our website at [www.vent-axia.com](http://www.vent-axia.com).

### Commissioning Record

Record the unit commissioning settings here.

Date	Settings Code	Who

For details of the settings code, see *The Settings Code on page 25*.

## Dimensions

Model	Dimensions (mm)								
	a	b	c	d	e	f	g	h	i
Mini/Midi	1700	1820	400	1212	1130	535	358	250	60
Maxi	1800	1924	-	1212	1130	530	660		60

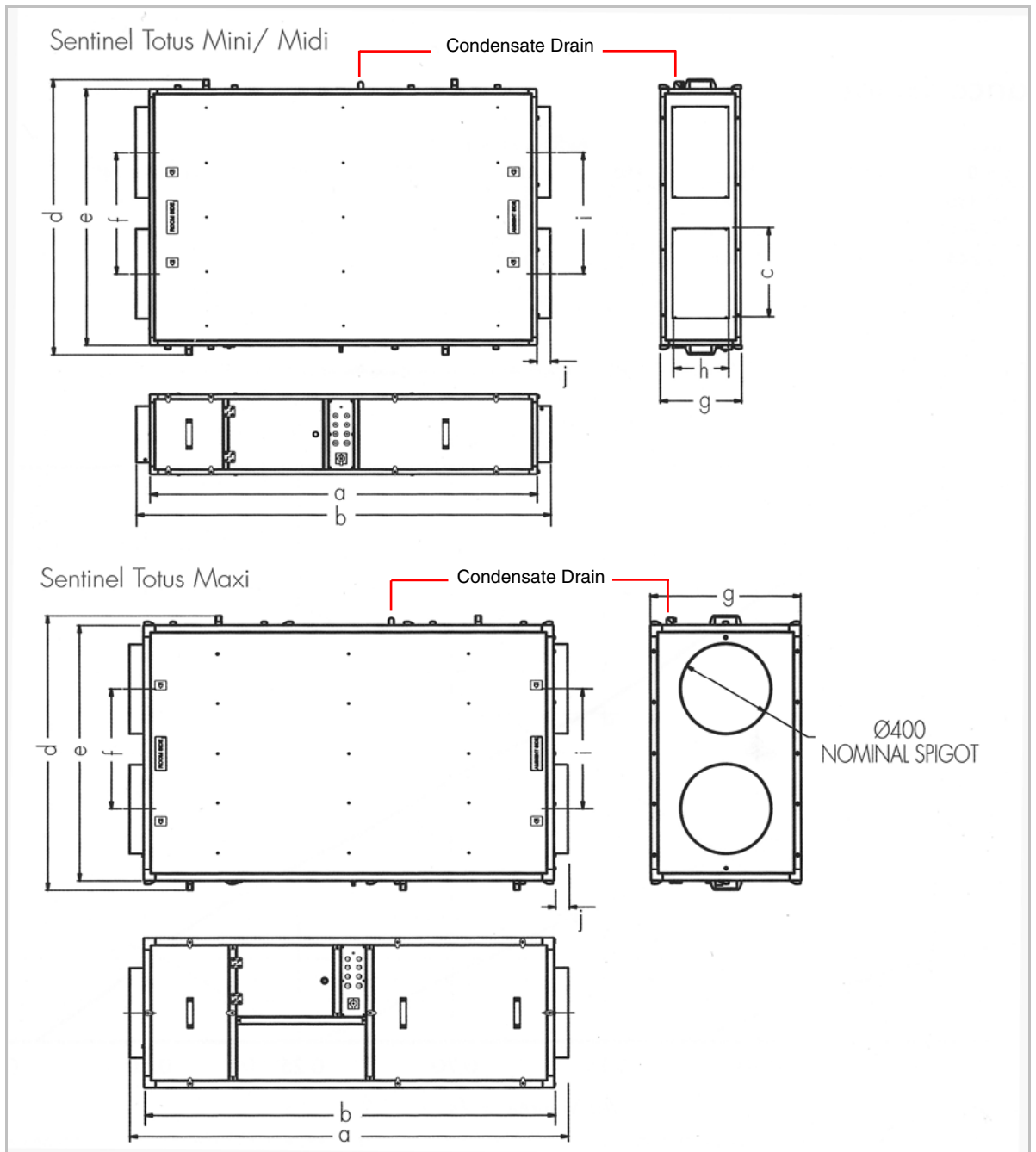

Figure 2: Unit Dimensions

# Installation

## Installing Your Energy Recovery Ventilation System



**WARNING**

**THIS EQUIPMENT PRESENTS ELECTRICAL, MECHANICAL AND NOISE HAZARDS. FAILURE TO USE SAFE WORKING PRACTICES AND OBSERVE THE RELEVANT REGULATIONS MAY RESULT IN DEATH OR SERIOUS INJURY.**

The following instructions are intended to help prevent and/or minimize potential hazards and should be carried out only by a qualified electrician and installer.

### How to Install Your Energy Recovery Ventilation System

The figure below summarises the instructions given in the following paragraphs.

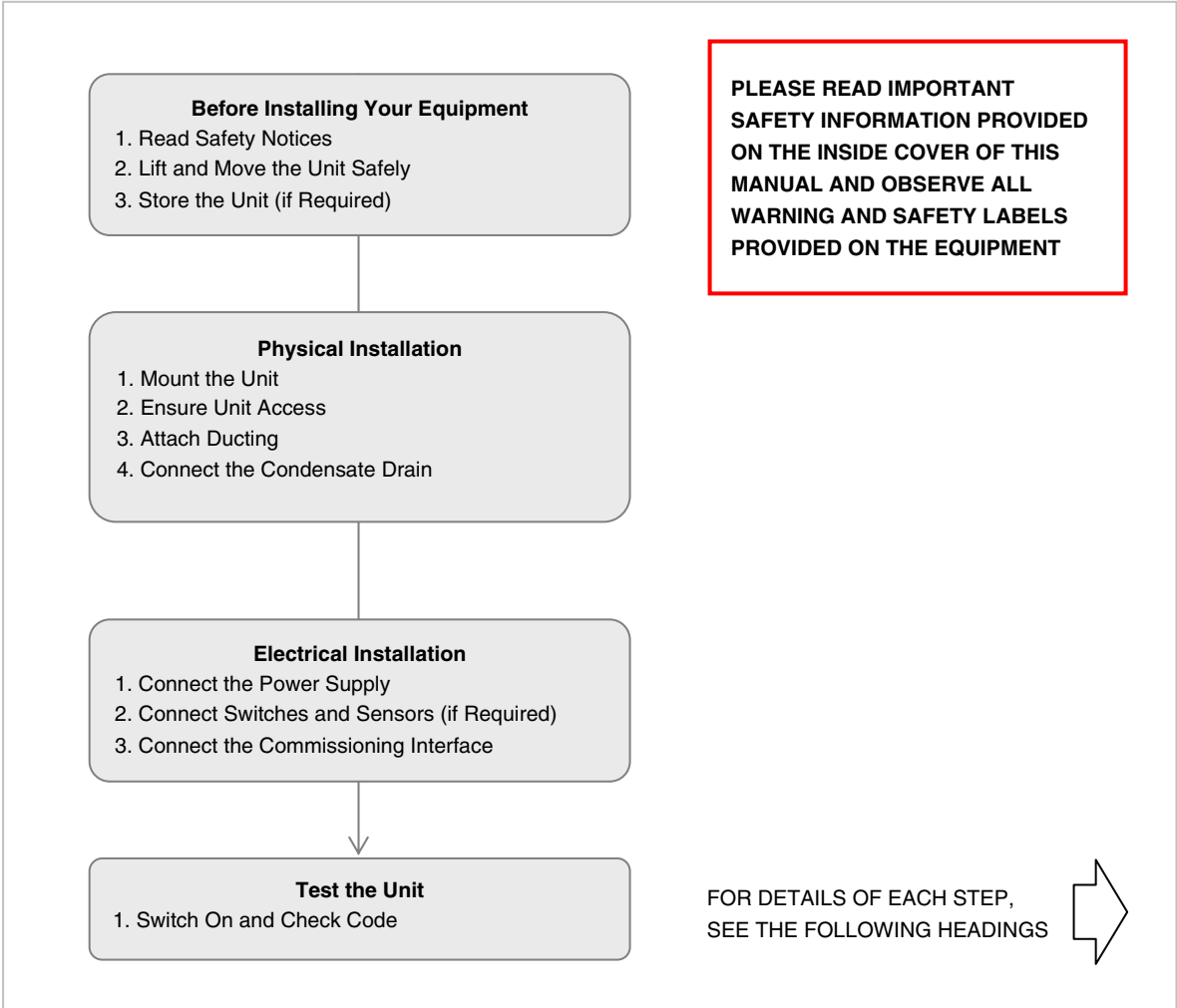

Figure 3: Installation Overview

## Before Installation Your Equipment

### Read Safety Notices

The equipment must be handled carefully and thoughtfully to prevent safety hazards and damage. Ensure the personnel designated to install the unit have the appropriate skills and knowledge.

Before commencing installation, please read and observe the safety notices given in the inside front cover of this manual.

### Inspect the Unit

The unit is supplied on a pallet, shrink-wrapped in polythene. When taking delivery of the unit, check the items delivered against the enclosed delivery note. Inspect the unit for damage in transit. If in doubt, contact Customer Services.

### Lift and Move the Unit Safely

This weight of this unit is detailed in the *Technical Specification on page 5*. Always use appropriate lifting techniques and appliances when moving heavy equipment. A forklift truck, crane or similar lifting gear is required to lift and move the unit. Support the unit under the 3 support points, as shown in *Figure 4*.

### Store the Unit (if Required)

If the unit is to be stored for a long period of time the fan impellers must be rotated by hand at monthly intervals to prevent hardening of the lubricant and corrosion or static indentation of the bearings.

If the unit has been stored, it is recommended that before installation, the resistance to earth should be measured. If found to be less than 2 M $\Omega$ , the unit should be left in a warm dry room for 24 hours and re-measured before applying mains voltage. If the resistance is still less than 2 M $\Omega$ , there is likely to be a fault.

The unit must be stored in clean, dry conditions.

## Physical Installation

### Check Site Requirements

Before installing the unit, check that the physical and environmental conditions for the site meet, or exceed, the requirements detailed in the *Technical Specification on page 5*.

DO NOT install these fans in areas where the following may be present:

- Excessive oil or grease laden atmosphere.
- Corrosive or flammable gases, fluids or vapours.
- Possible obstructions that will hinder removal.

### Mount the Unit

The unit is designed for stationary use and **MUST** always be mounted horizontally with a 2° tilt on the long side (the motor end should be lower) and horizontally with no tilt on the short side, to ensure drainage of the condensate tray. **DO NOT** mount this unit vertically.

Do not use this unit as a support for any other equipment.

This unit may be roof mounted or hung suspended from the ceiling. Always use the recommended fixings, supports, studs and hangers; and ensure that the unit is firmly and safely located.

### Roof or Floor Mounting the Unit

The unit **must** be mounted on three supporting blocks, as shown in the figure below. Ensure that the blocks are placed according to the alignment arrows on the sides of the unit.

If required, fit the weather cowl at the ambient end (external intake and exhaust). The cowl contains a division plate to prevent short-circuiting of airflows and prevents rain ingress on the intake.

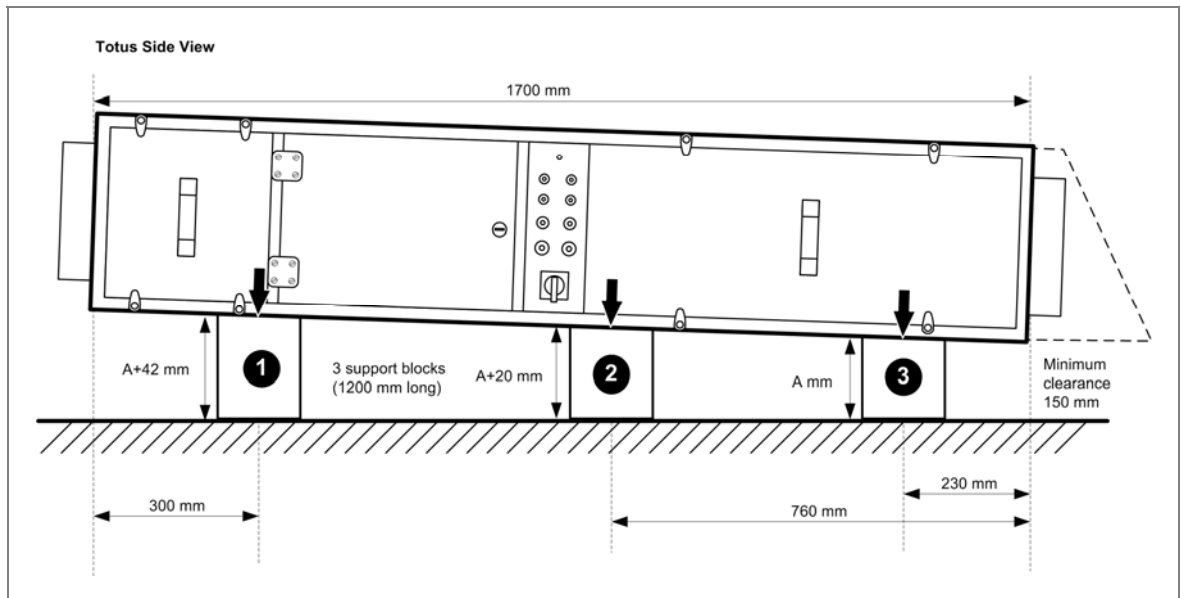

Figure 4: Unit Roof or Floor Mounted (Recommended)

## Suspending the Unit from a Ceiling

The unit is designed for stationary use and **MUST** always be mounted horizontally with a 2° tilt on the long side (the motor end should be lower) and horizontally with no tilt on the short side, to ensure drainage of the condensate tray. **DO NOT** mount this unit vertically.

The unit **must** be suspended on six drop-rods and horizontal cradle, as shown in the figure below. Ensure the drop-rods and cradle are of sufficient strength to support the weight of the unit. Align that the drop-rods with the arrows on the sides of the unit and ensure they are mounted 350 mm away from both the sides of the unit to allow opening of access panels.

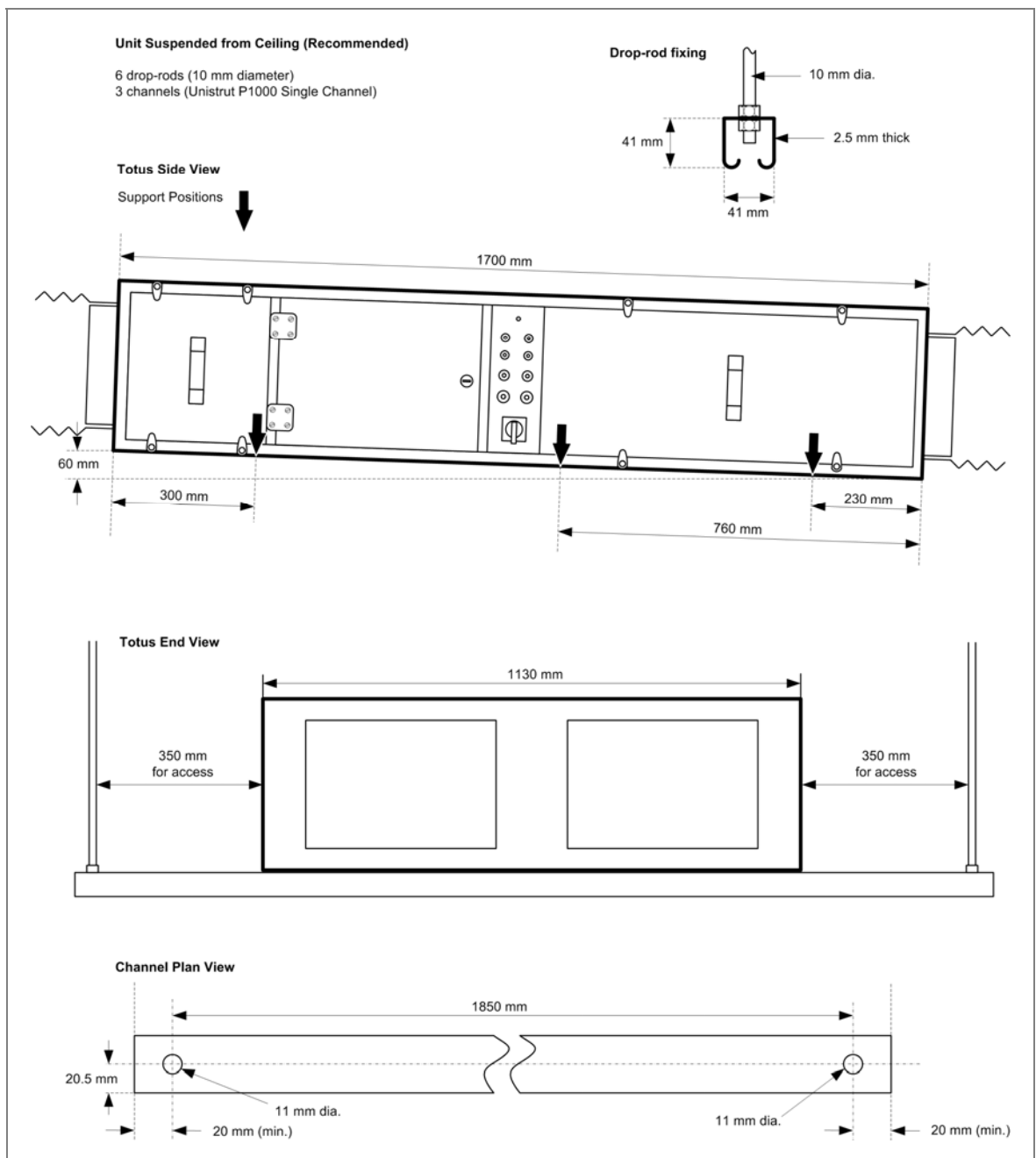

Figure 5: Unit Suspended from Ceiling (Recommended)

## Ensure Unit Access

Ensure the equipment is installed in such a way as to allow access to the control unit and connectors. Check the dimensions of the unit detailed in the *Technical Specification*. Note that the control door requires a 350 mm space in order to open fully.

## Attach Ducting

### WARNING

**IF THIS EQUIPMENT IS RUN WITHOUT DUCTING FITTED, THERE IS A POTENTIAL HAZARDS FROM ROTATING PARTS THAT CAN BE REACHED DURING OPERATION.**

Fit appropriate ducting to the unit in accordance with the supplied drawings for the building.

Fit flexible connectors adjacent to the unit. Ensure they are taut.

When fitting clamping bands to flexible connectors, ensure that the flexible connectors are pulled tight and the ducts are not misaligned.

The Sentinel mini and midi provide rectangular ducting interfaces. Fit adapters as necessary to connect to ducting with a circular cross-section.

In order to facilitate access to, and replacement of, the extract motor on the external/ambient side, a suitable, easily disconnected section of ducting should be fitted, if ducting is required, in installations where the unit is mounted internally.

## Connect the Condensate Drain

The unit should be mounted in a horizontal position with a 2° tilt towards the motor (ambient) end to ensure drainage of the condensate drain.

Use 10 mm pipe or flexible hose to connect to the condensate drain in order to carry away any water produced because of internal condensation. Ensure that the water is routed to a suitable outlet, which can be up to 12 m above the unit as there is an internal pump. This pipe should be insulated if installed in an area that could freeze.

## Electrical Installation

The power supply connections are accessible at the unit enclosure.

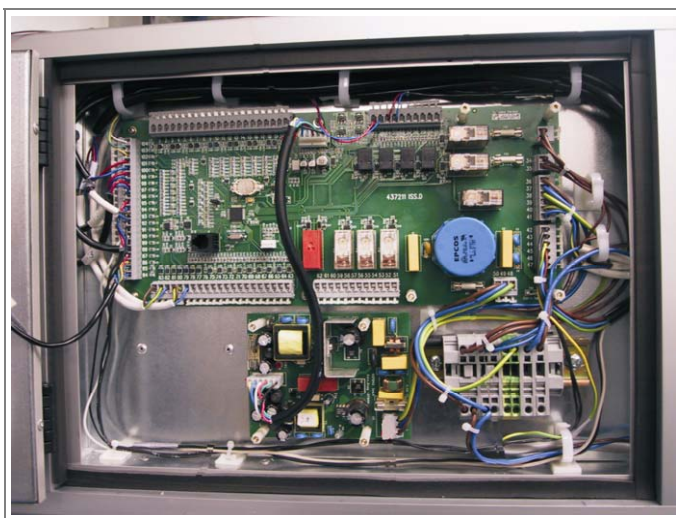

Figure 6: Unit Enclosure

## Connect the Power Supply



### WARNINGS

1. MAINS SUPPLY VOLTAGES (220-240 V AC) ARE PRESENT IN THIS EQUIPMENT WHICH MAY CAUSE DEATH OR SERIOUS INJURY BY ELECTRIC SHOCK. ONLY A QUALIFIED ELECTRICIAN OR INSTALLER SHOULD CONNECT THE POWER SUPPLY TO THIS UNIT.
2. THIS UNIT MUST BE CORRECTLY EARTHED IN ORDER TO PROVIDE OVERCURRENT AND EARTH FAULT PROTECTION.
3. DO NOT OVERLOAD WALL OUTLETS AND EXTENSION CABLES AS THIS MAY RESULT IN A RISK OF FIRE OR ELECTRIC SHOCK.

Check the *Technical Specification* for the voltage, current and fusing information relevant to this product.

This unit is designed for operation from a single-phase alternating current source (220-240 V ac). The wiring to the unit should be routed via a double-pole isolating switch (in accordance with local electrical wiring regulations) adjacent to the unit, or taken from the distribution board.

1. Ensure the local ac power supply is isolated before connecting the supply cable.
2. Ensure the correct fuse type, or circuit breaker has been fitted to the ac power input supply. A means of disconnection should also be provided in the fixed wiring.
3. Connect a suitable round power cable through the cable gland provided. A 7-10 mm diameter cable should be used to ensure sufficient grip by the cable gland. The gland **MUST** be sealed properly to maintain the IP rating of the unit. Open the controls hinged door and feed the cable through the unit to the Main Controller PCB located in the controls enclosure. It may be necessary to remove the gland plate in order to feed the cable through - unscrew the six fixing screws securing the gland plate to the chassis.
4. Connect the L/N/E supply to the terminals as identified on the DIN rail, see figure below.

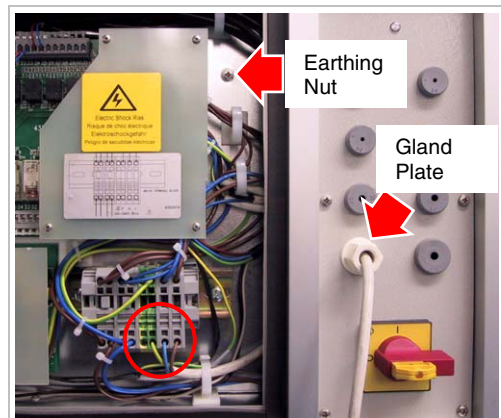
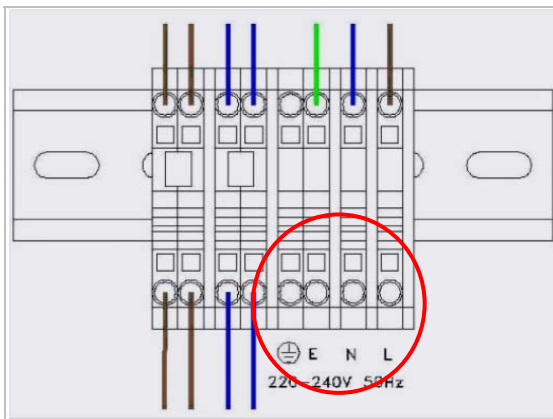

Figure 7: Power Supply Connections

5. Connect the other end of the cable to the main power supply outlet.
6. Ensure the unit remains isolated until all external connections are made.

## Connect Switches and Sensors

Connect any required switches and/or sensors as recommended by the system designer in the drawings supplied by him.

A 24 V dc nominal (18-30 V dc) supply at 350 mA max is provided for powering switches and sensors, etc. Analogue signal returns must be 0-10 V dc with common ground for the instrument and cable screen at the control board.

The terminal connections provided by the Main Controller PCB for connecting to switches, sensors, etc., are shown below. Other terminals are connected as required at the factory. DO NOT disconnect any factory fitted connections.

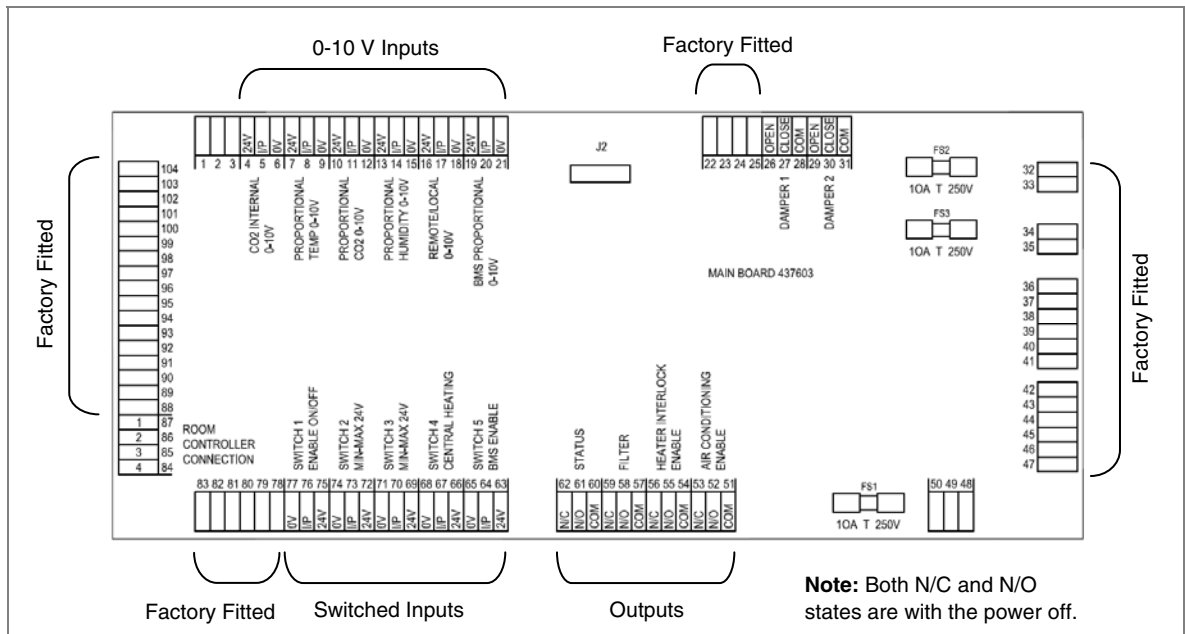

Figure 8: Main Controller PCB Terminal Connections

## Connect the Commissioning Interface

The Commissioning Interface must be mounted indoors or inside the control enclosure.

Ensure the Commissioning Interface is accessible for commissioning and maintenance. It is recommended that it be mounted near to the main supply isolator, if not inside the control enclosure, since the unit must be switched off and on to access the commissioning screen.

To connect the Commissioning Interface:

1. Open the Commissioning Interface casing to gain access to the interior by inserting a small flat-bladed screwdriver in the slot at the base of the case. Then separate the front and rear halves at the top.

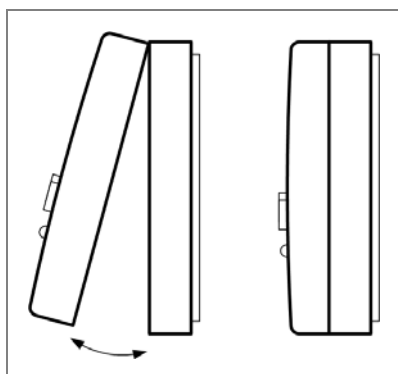

Figure 9: Opening the Commissioning Interface

2. Mark and drill the holes for the two fixing screws supplied with the mounting kit. Fix the wall plugs and screws to the wall, leaving the screw heads sufficiently proud of the wall to enable the Commissioning Interface to be attached by lining up the holes in the rear of the casing with the screws and resting the case on the screws.

3. Use 4-core 0.5 mm<sup>2</sup> DEF STAN 61-12 Part 5 Type A cable, or equivalent, to connect the Commissioning Interface to the Main Controller PCB. The diameter of the cable used must not exceed 4 mm in order to pass through the opening of the Commissioning Interface's plastic housing. The length of the cable should not exceed 10 m. Screened cable is recommended, with screen connected to the chassis. Unscreened cable may be used if there is no threat from external electrical interference.

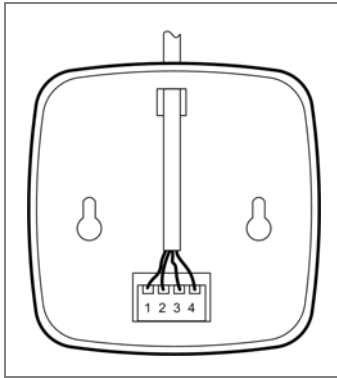

Figure 10: Commissioning Interface Connections

4. Connect pins 1-4 on the Commissioning Interface terminal block to the corresponding pins 1-4 on the Main Controller PCB, see *Figure 8: Main Controller PCB Terminal Connections*, i.e. connect Commissioning Interface pins 1 to 87, 2 to 86, 3 to 85 and 4 to 84.
5. Re-assemble the front and rear halves of the Commissioning Interface Casing by first re-engaging the two lugs and slots along the top. Then, press together the bottom edges of the two halves, which should close with an audible click.

## Switching On

The following procedure assumes that all necessary installation actions have been performed in accordance with the instructions given in this section of the manual.

To switch the unit on:

1. Ensure that all side panels are fitted and properly secured, using a 5 mm Allen Key.
2. Switch on the power at the mains outlet feeding the Sentinel unit.
3. At the unit's cable entry panel, turn the isolator switch to position 1 (ON).
4. Observe the Commissioning Interface. Following switch-on, the Commissioning Interface displays three start-up screens.
  - a) The first start-up screen displays the Sentinel Totus model and software version number.

```
Vent-Axia  
Sentinel HR V009
```

- b) The second start-up screen displays the clock and settings code. Check the code displayed corresponds to the unit you are installing. If the unit has already been commissioned, another code will be displayed, check that this agrees with the code noted on the Installer Notice label. As delivered from the factory, the settings code will be either **000X00** (for a standard unit) or **400X00** (for a CP unit), where X is a number (see *The Settings Code on page 25* for an explanation of the code).

```
Clock      Code  
Tue 07:09 111300
```

- c) The third start-up screen displays a “**Commissioning ?**” message, to which you have 10 seconds to press the **Enter (↵)** push-button in order to modify the factory default settings. If you are NOT commissioning the unit, DO NOT respond to this message. After 10 seconds, the normal status monitoring screens will be displayed and you will not be able to enter the commissioning screens without turning the unit on and off again.

**Commissioning?  
Press Enter 10s**

5. Ensure that the Status LED on the Commissioning Interface is green, indicating that the unit is operating normally. The unit will commence operation according to the stored parameters.
6. If commissioning is required, or if the parameters are to be altered, see the following *Commissioning* section.

## Switching Off

To switch the unit off:

1. At the unit’s cable entry panel, turn the isolator switch to position **0** (OFF).
2. If you are intending to carry out work or maintenance inside the unit, switch off the power at the mains outlet supplying the unit before you remove the covers.
3. To prevent the equipment being accidentally switched on while you are away from it, pull out the yellow inner section of the isolator switch to lock the isolator in position, revealing a hole through which a padlock, or other lockable device, may be inserted.

### Note

All commissioning settings are permanently stored in non-volatile memory and, therefore, retained in the event of a shutdown or power failure.

## Commissioning

### Commissioning Your Energy Recovery Ventilation System

The instructions in this section are intended to provide configuration and operation information for setting up the equipment. In the event of problems, see *Troubleshooting*.

#### Commissioning Interface

The Commissioning Interface can be hard wired to any remote location. The Commissioning Interface provides the user interface for commissioning and monitoring purposes. Data communication to the Main Controller PCB are set up via a code-lock facility.

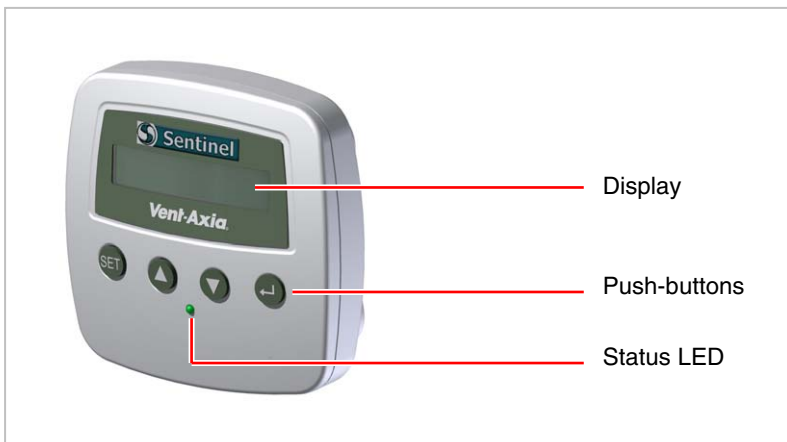

Figure 11: Commissioning Interface

#### Display

The main display is a 16 character, 2-line liquid crystal display (LCD) with automatic backlight, which is turned off to minimise power consumption when the unit is operational (see *Commissioning Interface Screens* on page 18).

```
Vent-Axia  
Sentinel HR V009
```

#### Push-buttons

Four push-buttons on the Commissioning Interface provide the controls for configuring and monitoring the unit.

Table 2: Commissioning Interface Push-buttons

Push-button	Function
Set	Press to adjust settings and move to next menu item.
Up (▲)	Press to go to the above screen or to increase a parameter value. Press and hold for fast response.
Down (▼)	Press to go to the next screen or to decrease a parameter value. Press and hold for fast response.
Enter (↵)	Press to enter or move to next menu item.

## Status LED

A 3-way, multi-colour LED on the Commissioning Interface displays the status of the unit. A similar LED is provided at the top of the cable entry panel, on the side of the unit, to provide a local indication of the unit status in the event that the Commissioning Interface is located remotely.

Table 3: Commissioning Interface Status LED

LED Colour	Function
Green	The unit is healthy and operating normally.
Red/Green Flashing	The unit requires the filters to be changed. The unit will continue to operate normally. <i>See Fault LED/Status Relay on page 32.</i>
Red Flashing	The unit has a fault that should be investigated immediately. Operation of the unit is stopped. <i>See Fault LED/Status Relay on page 32.</i>

## How to Commission Your Energy Recovery Ventilation System

The factory default operating mode will be either Constant Pressure or MIN-MAX.

Following switch-on, the unit displays the “**Commissioning ?**” message to which you have 10 seconds to press the **Enter (↵)** push-button in order to modify the factory defaults. If you DO NOT respond, the current stored parameters will remain and the unit will run in the current stored mode. If you respond by pressing the enter push-button, the unit will perform some self-diagnostics and enter the commissioning screens.

Perform the appropriate commissioning, according to which mode is to be used, as detailed in the following pages.

When commissioning has been performed:

- if an input signal is detected at a proportional input terminal, over a default threshold (P-band), the unit will go into proportional control mode
- if a signal is detected at a remote/local input terminal, the unit will go into that control mode.
- If no other signals are detected, the unit will remain in CP or MIN-MAX mode.

### Note

1. If the mode displayed is not the required mode, it can be changed by turning off the unit, then re-entering the commissioning procedure.
2. All commissioning settings are permanently stored in non-volatile memory and, therefore, retained in the event of a shutdown or power failure.

## Commissioning Interface Screens

When the unit is switched on (see *Switching On on page 14*), the following Commissioning Interface screens are available for monitoring and configuring the unit.

There are three types of screens displayed:

- **Start-up screens** – these are displayed for a few seconds when the unit is first switched on.
- **Status monitoring screens** – each are displayed in continuous loop during the operation of the unit.
- **Commissioning screens** – these are only available when the enter push-button is pressed in response to the relevant “**Commissioning ?**” screen.

An overview of the all the available screens is given below (default values shown). See the following pages for detailed screen descriptions.

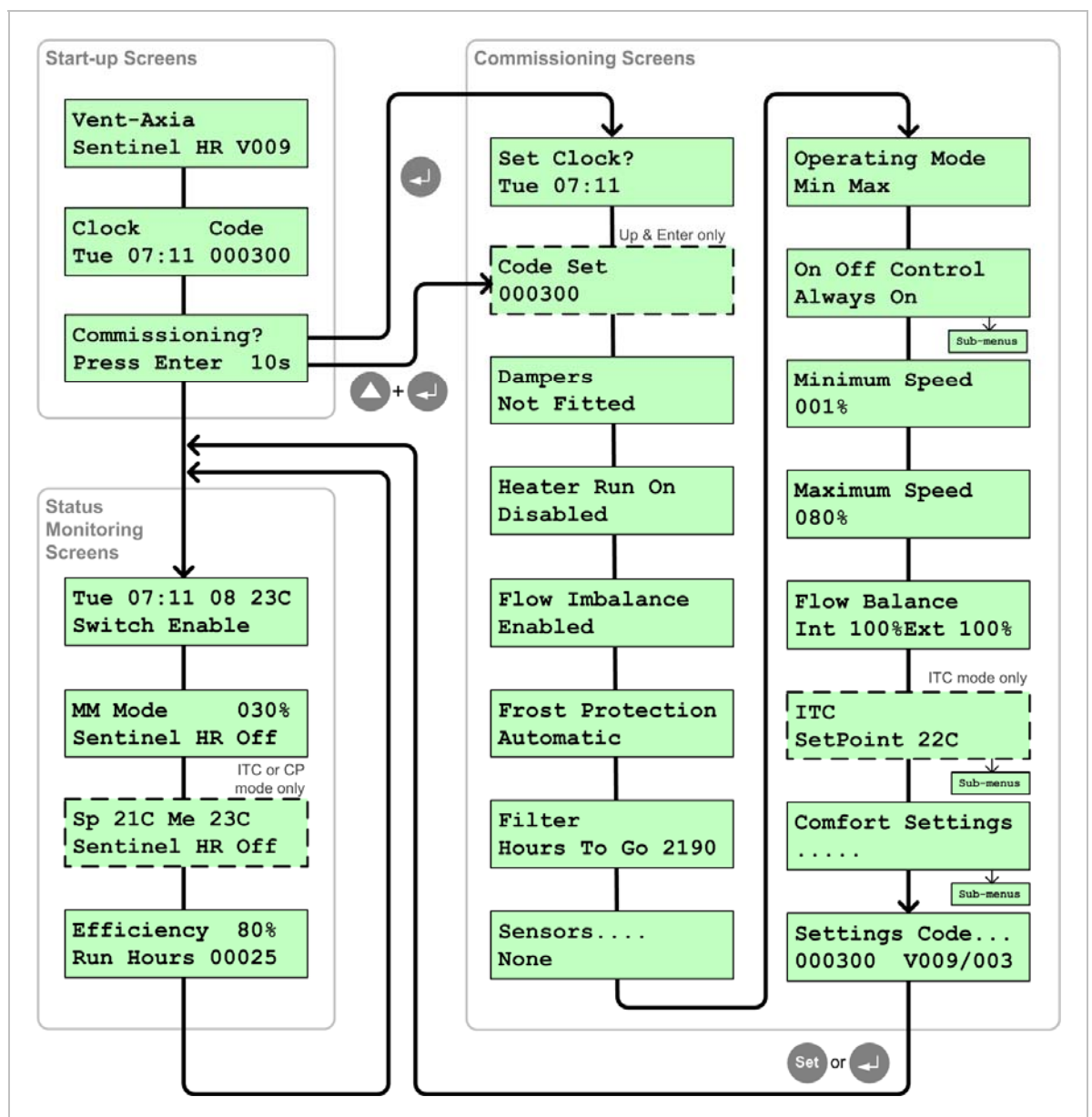

Figure 12: Commissioning Interface Screens Overview

## Commissioning Screens

The commissioning screens are only available if the **Enter** push-button is pressed when the “**Commissioning?**” screen is displayed before the 10 second countdown reached zero. These screens enable the unit to be configured to suit installation requirements.

### Set Clock Screen

The Set Clock screen displays the current local time. The Main Controller PCB provides the clock electronics and a battery back-up for when the unit is switched off. If the battery is replaced, the clock will need to be set again using this screen. Note that other commissioning settings are permanently stored in non-volatile memory and, therefore, retained in the event of a shutdown or power failure.

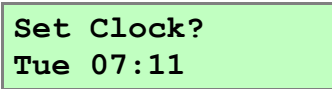

```
Set Clock?  
Tue 07:11
```

Press **Set** and then use the **Up** and **Down** push-buttons to adjust the day setting (**Mon, Tue, Wed, Thu, Fri, Sat, Sun**).

Press **Set** again and then use the **Up** and **Down** push-buttons to adjust the hours setting (**00-24**).

Press **Set** again and then use the **Up** and **Down** push-buttons to adjust the minutes setting (**00-59**).

Press **Set** again to enter the new settings and move down to the next screen.

### Code Set Screen

The Code Set screen is only accessible when the **Up** and **Enter** push-buttons are pressed in response to the “**Commissioning?**” screen. This screen enables the settings code to be changed on a replacement Main Controller PCB, as an alternative to re-entering the settings using the commissioning screens to re-establish the unit configuration, or where multiple units need to be commissioned at the same site with the same settings.

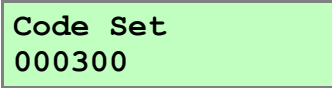

```
Code Set  
000300
```

Press **Set** and then use the **Up** and **Down** push-buttons to enter each of the 6 appropriate code numbers (see *The Settings Code on page 25*).

Press **Set** again to enter the new settings and move down to the next screen.

### Dampers Screen

Back draft dampers may be fitted that close when the unit goes to standby to prevent draughts. The Dampers screen displays whether dampers are wired directly to the unit (to terminals 26-31).

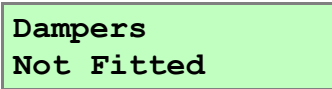

```
Dampers  
Not Fitted
```

Press **Set** and then use the **Up** and **Down** push-buttons to select one of the two available options (**Fitted** or **Not Fitted**). Default value shown.

Press **Set** again to enter the new settings and move down to the next screen.

### Heater Run On Screen

The Heater Run On screen enables a time to be set for the fan motors to keep running when an external duct heater, if fitted, is turned off to allow cooling airflow to dissipate the heat.

**Heater Run On  
Disabled**

Press **Set** and then use the **Up** and **Down** push-buttons to select one of the two available options (**Enabled** or **Disabled**). Default value shown.

If **Enabled** is selected, press **Set** again and then use the **Up** and **Down** push-buttons to adjust the time setting in seconds (**30-180**).

Press **Set** again to enter the new settings and move down to the next screen.

## Flow Imbalance (for Frost Protection) Screen

The Flow Imbalance screen enables a proportional change of supply and extract in Frost Protection mode and comfort settings.

### Note:

For setting an imbalanced airflow for other reasons, see *Flow Balance Screen on page 22*.

**Flow Imbalance  
Disabled**

Press **Set** and then use the **Up** and **Down** push-buttons to select one of the two available options (**Enabled** or **Disabled**). Default value shown.

Press **Set** again to enter the new settings and move down to the next screen.

## Frost Protection Screen

The Frost Protection screen displays options for the protection of the unit against frost. Protection measures may be factory set, in which case no selectable options will be available.

**Frost Protection  
Automatic**

Options that may be displayed on this screen are **Automatic**, **Flow Imbalance** or **Bypass Mode**.

Press **Set** again to enter the new settings and move down to the next screen.

## Filter Screen

The Filter screen displays the hours to go before replacement of the fan filters is necessary. The number of hours runs down from **2190** (3 months) to **0000**. There are no selectable options on this screen.

**Filter  
Hours To Go 2190**

When the time runs down to **0000**, a fan filter alarm will be displayed, the filters must be replaced and the screen displays **Replaced/No/Yes**. When **Yes** is selected the timer is reset to back to **2190**.

Press **Set** to move down to the next screen.

## Sensors Screen

The Sensors screen detects for any proportional environmental sensors connected to the unit when the unit is first switched on. The screen may display one of the following options **None**, **Constant Pressure**, **BMS**, **Proportional** alternating with **Update?**, depending on the sensor(s) detected.

**Sensors . . . .**  
**None**

Press **Set** to update the screen and perform a manual detection check on the unit. The lower half of the display will display a **Checking** message. If new sensors are detected, their parameters are displayed and used to automatically place the unit in a suitable operating mode. If a pressure sensor is fitted, then Constant Pressure mode is used. If a CO<sub>2</sub> sensor is fitted, then Proportional mode is used and the unit will search for other sensors. If sensor(s) are found then Proportional mode is used. If a BMS 0 -10 V input is found then BMS mode is used. If BMS enable input found (i.e. contact closed) then BMS mode is used. Otherwise, Min Max mode is used by default.

Press **Set** to move down to the next screen.

## Operating Mode Screen

The Operating Mode screen displays the mode of the unit when running in normal operation. This may be enabled automatically by the detection of relevant sensors, or may be manually adjusted. Note that some options on other screens may be affected by the choice of operating mode.

**Operating Mode**  
**Min Max**

Press **Set** and then use the **Up** and **Down** push-buttons to select one of the available options (**Constant Pressure, Min Max, BMS, Proportional** or **ITC**).

- **Constant Pressure** – entered automatically if a pressure sensor is detected on start-up. In this mode, the fan speed responds to maintain a constant fan inlet negative pressure as a result of downstream duct resistance variations. A pressure sensor with a 0-10 V proportional input is used to drive the fan speed.
- **Min Max** – a manually selectable option. In this mode, the unit responds to switch inputs (time, thermostat, PIR, humidistat or AQS switch). The switch input causes the fan speed to change from the minimum (trickle) to the maximum (boost) speed.
- **BMS** – a manually selectable option. In this mode, an external Building Management System is used to proportionally control the unit fan speed. When this mode is selected, the On Off Control mode is automatically set to BMS Enable.
- **Proportional** – a manually selectable option. In this mode, the unit fan speed responds proportionately to either the CO<sub>2</sub>, temperature or humidity sensor proportional inputs.
- **ITC** – a manually selectable option. In this Internal Temperature Control mode, the exhaust air temperature (T4) is compared against a user-settable room temperature.

Press **Set** to move down to the next screen.

## On Off Control Screen

The On Off Control screen displays the method by which the unit is taken out of standby mode.

**On Off Control**  
**Always On**

Press **Set** and then use the **Up** and **Down** push-buttons to select one of the available options (**Always On, Switch Enable, BMS Enable** or **Internal Clock**). Default value shown.

- **Always On** – the unit is always operational and does not run on standby (typically used in environments that are occupied 24 hours a day, such as hospitals).
- **Switch Enable** – the unit may be turned on by means of a physical switch (typically a wall switch in the room). When not turned on, the unit will be in standby mode.

- **BMS Enable** – the unit may be turned on by a Building Management System (typically a computer-controlled relay). This may be configured as a time controller or use other switches or sensors to control the turn on of the unit. When **BMS** is selected as the Operating Mode, **BMS Enable** is automatically selected as the On Off Control and no further options are selectable.
- **Internal Clock** – the unit may be turned on according to a timer that may be set by additional screens. Use the **Set**, **Up** and **Down** push-buttons to select an on and off time for each day of the week.

```
Day On   Off
Mon 07:00 18:00
```

Press **Set** to move down to the next screen.

## Minimum Speed Screen

When in min max mode, the Minimum Speed screen enables the minimum speed for the fan motors.

```
Minimum Speed
010%
```

Press **Set** and then use the **Up** and **Down** push-buttons to select a percentage.

Press **Set** again to enter the new settings and move down to the next screen.

## Maximum Speed Screen

When in min max mode, the Maximum Speed screen enables the maximum speed for the fan motors.

```
Maximum Speed
080%
```

Press **Set** and then use the **Up** and **Down** push-buttons to select a percentage.

Press **Set** again to enter the new settings and move down to the next screen.

## Flow Balance Screen

The Flow Balance screen enables the balance between intake and extract motor speed to be adjusted. An imbalance may be set between the in and out airflow, if required. The motors are allowed to run at different speeds, enabling a room to be kept at positive or negative pressure.

```
Flow Balance
Int 100%Ext 100%
```

Press **Set** and then use the **Up** and **Down** push-buttons to set the **Intake** percentage (**80-120%**).

Press **Set** and then use the **Up** and **Down** push-buttons to set the **Extract** percentage (**80-120%**).

Press **Set** again to enter the new settings and move down to the next screen.

## ITC Screen

This screen is only displayed if ITC mode is selected at the Operating Mode screen (see *Operating Mode Screen on page 21*). The ITC screen enables the Internal Temperature Control mode settings to be adjusted.

```
ITC
SetPoint 22C
```

Press **Set** and then use the **Up** and **Down** push-buttons to adjust the temperature (in degrees C) for the ITC setpoint (**10-35**). This is the target room temperature.

Press **Set** again to enter the new settings and move down to the next screen.

```
ITC
Passband 10C
```

Press **Set** and then use the **Up** and **Down** push-buttons to adjust the temperature (in degrees C) for the ITC passband (02-50). This is the range of temperatures that proportionally control the motor speed from minimum to maximum.

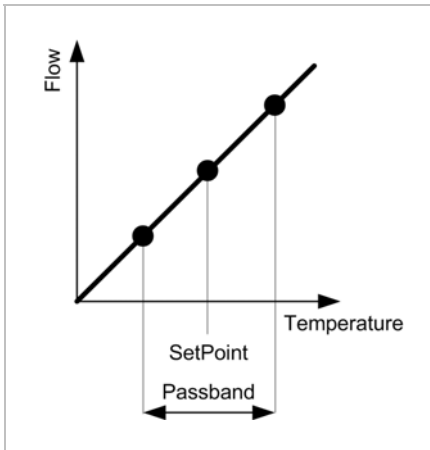

Figure 13: Graph of Flow versus Temperature

Press **Set** again to enter the new settings and move down to the next screen.

## Comfort Settings Screen

The Comfort Settings screen enables comfort, bypass and overheat settings to be adjusted.

- **Comfort** – cools the room by either varying the fan speed, or by opening the bypass, or in proportion to extract air (T3) when a threshold temperature is reached.
- **Bypass** – cools the room by opening the bypass when a threshold temperature is reached.
- **Overheat** – cools the room when triggered by a high extract air (T3) at 3 pm, then runs at night when intake air (T1) is cool.

### Note

Comfort control is not available with ITC mode or Proportional with external temperature sensor because they both deal with a warm room by running the fans faster.

```
Comfort Settings
.....
```

Press **Set** then use the **Up** and **Down** push-buttons to select the **Comfort Enable/Disable** option.

```
Comfort Settings
Comfort Enable
```

If **Comfort Enable** is selected, pressing **Set** again enables you to select a temperature (in degrees C) for the comfort setting (20-29). This is the target room temperature.

```
Comfort Settings
Comfort      29C
```

Press **Set** again to enter the new settings and move down to the next screen. Use the **Up** and **Down** push-buttons to select the **Bypass Enable/Disable** option. This enables or disables the Summer Bypass.

```
Comfort Settings
Bypass      Enable
```

If **Bypass Enable** is selected, pressing **Set** again enables you to select a temperature (in degrees C) to initiate the bypass (16-30) using the **Up** and **Down** push-buttons. This is the target room temperature.

```
Comfort Settings
Bypass      29C
```

Press **Set** again to enter the new settings and move down to the next screen. Use the **Up** and **Down** push-buttons to select the **Overheat Enable/Disable** option. This allows an overnight purge to happen when there is a large thermal mass that has overheated during the day.

```
Comfort Settings
Overheat Enable
```

If **Overheat Enable** is selected, pressing **Set** again enables you to select a temperature (in degrees C) for the summer overheat trigger upper temperature (21-40) using the **Up** and **Down** push-buttons.

```
Comfort Settings
Overheat >  30C
```

Press **Set** again to enter the new settings and move down to the next screen. Use the **Up** and **Down** push-buttons to select a temperature (in degrees C) for the summer overheat stop lower temperature (10-20).

```
Comfort Settings
Overheat <  20C
```

Press **Set** again to enter the new settings and move down to the next screen.

## Settings Code Screen

The Settings Code screen displays a six-digit code that represents the commissioning parameters that have been set (see *The Settings Code on page 25*). It also displays the Main Controller PCB software version number and the Commissioning Interface version number.

```
Settings Code
000300 v009/003
```

Press **Enter** to exit the commissioning screens and move back to the Status Monitoring screens.

## The Settings Code

The settings code is displayed on the last commissioning screen (see *Settings Code Screen*) and also on the start-up screens (see *Clock/Code Screen*). The code corresponds to the settings selected on the commissioning screens, as shown below.

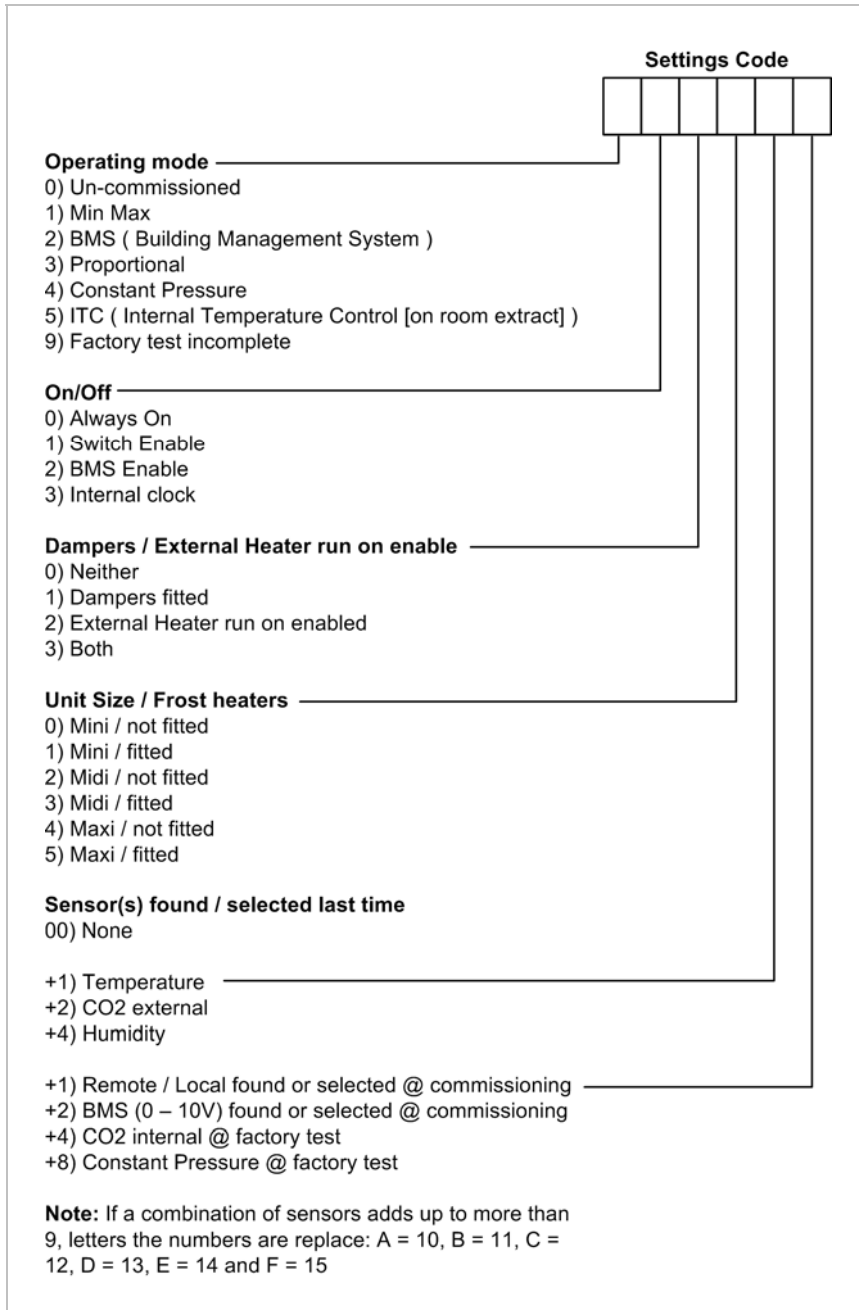

Figure 14: Settings Code

## Writing Down the Settings Code

On completion of commissioning, write down the settings code, corresponding to the chosen settings, on the **Installer Notice** label provided and on the *Technical Specification on page 5* of this manual.



Figure 15: Installer Notice Label

The commissioning settings are stored in non-volatile memory on the Main Controller PCB and will be automatically restored after a shutdown or power outage. The internal clock is maintained during a power failure by a battery on the Main Controller PCB. If this system fails for any reason, the configuration code written on the back of the door may be used to reinstate the settings.

Using the settings code is a quick way to restore the settings of a unit. It is also a quick way to configure multiple units in a large installation if they are all required to operate in the same way.

**Note:**

The settings code WILL NOT restore **time settings** or **comfort settings**, which will be set to the default settings. These must, therefore, be set manually on each unit using the commissioning screens provided by the Commissioning Interface.

## Default Settings

The following default commissioning settings are present when the unit is switched on.

Table 4: Default Settings

Parameters	Settings
Set Clock	-
Dampers	Not fitted
Heater Run On	Disabled
Flow Imbalance	Enabled
Frost Protection	Auto, if heaters fitted
Filter	2190
Sensors	-
Operating Mode	-
On Off Control	Always On (if Internal Clock selected default on off = 6:30 – 22:30)
Minimum Speed	1%
Maximum Speed	80%
Flow Balance	Int 100% , Ext 100%
ITC	-
Comfort Settings	Comfort Enable (24C), Bypass Enable (20C), Overheat Enable (summer overheat trigger 30C and summer overheat stop 20C)
Settings Code	-

## Operation and Monitoring

### About Operation and Monitoring

When the Sentinel Totus unit has been installed and commissioned (see the previous sections) it should require no further intervention in order to operate, unless external switches are used to control on/off/boost, etc, or BMS control requires user action.

When the commissioning screens are exited, the Commissioning Interface display returns to the status monitoring screens, as described below (see also *Figure 12: Commissioning Interface Screens Overview on page 18*).

### Status Monitoring Screens

The status monitoring screens display status and key operational conditions (temperatures or pressures, etc.) according to how the unit has been configured. These screens are displayed in a loop during normal operation of the unit, either after displaying the start-up screens, or when commissioning has been completed. After a few seconds the display backlight is turned off in order to minimise power consumption. The **Up** and **Down** push-buttons can be used to stop the loop sequence in order to display individual screens for a longer period with the backlight turned on, if required.

#### Day/Time/Temp/On Off Mode Screen

This screen displays the following information.

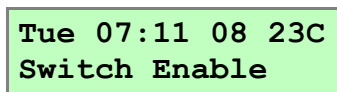

The screenshot shows a green rectangular box containing the text: "Tue 07:11 08 23C" on the top line and "Switch Enable" on the bottom line.

The top line displays day, time and temperature information:

- **Day**
- **Time**
- **Intake Temperature** (T1, see *Figure 1: Sentinel Totus on page 4*)
- **Extract Temperature** (T3, see *Figure 1: Sentinel Totus on page 4*)

When the **Day/Time** is displayed, press **Set** to adjust the clock (see *Set Clock Screen on page 19*).

The bottom line displays on/off mode control:

- **On Off Mode** – possible displays are **Always On**, **Switch Enable**, **BMS Enable**, **Internal Clock (Next On/Next Off)**

When the **On Off Mode** is selected, **Internal Clock** is displayed, press **Enter** to advance to the **Next On** or **Next Off** time (see *On Off Control Screen on page 21*).

#### Mode/Speed/Status Screen

This screen displays the following information.

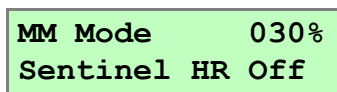

The screenshot shows a green rectangular box containing the text: "MM Mode 030%" on the top line and "Sentinel HR Off" on the bottom line.

The top line displays mode and motor speed information (see *Operating Mode Screen on page 21*):

- **MM Mode/Speed %**
- **BMS Mode/Speed %**  
**BMS signal %** (if BMS proportional is selected)

- **PR Mode/Speed %**  
R/L Signal % (factory fitted or found)  
CO2 internal signal ppm (during commissioning)  
T Signal C (during commissioning)  
CO2 External Signal ppm (during commissioning)  
H Signal % (during commissioning)
- **CP Mode/Speed %**  
Set point/Measured Pressure
- **CS Mode/Speed %**  
Set point/Speed %

The bottom line displays status:

- **Sentinel HR Off**
- **Sentinel HR On**
- **Dampers Opening**
- **Dampers Closing**
- **Bypass Closing**
- **Heater Run On**
- **Bypass Open + code**  
0 closing after an open event has finished  
1 power on test  
2 comfort control  
3 summer bypass  
4 overheat  
5 defrost
- **Bypass Fail**
- **Defrost Mode + code**  
1 – 10 imbalance mode speed  
50 / 51 heater 1 / heater 2  
60 fans at minimum  
61 and bypass open  
62 3 hour timeout and stop
- **Untested**
- **Uncommissioned**
- **Replace Filter**
- **Heating Fail + countdown**  
10 to 0 fans running  
60 to 0 fans stopped
- **Overheat Active + code**  
0 cancelling  
1 triggered @ 3pm  
2 running (from 2am)  
3 sampling (from 2am)  
4 going off
- **Comfort Control**
- **Starting....**

## Sp/Me Screen

This screen is displayed only when the unit is in Internal Temperature Control (ITC) or Constant Pressure (CP) mode.

```
Sp 21c Me 23C  
Sentinel HR On
```

- **Sp** – Setpoint (temperature or pressure)
- **Me** – Measured (temperature or pressure)

## Efficiency Screen

The Efficiency screen displays the following information.

```
Efficiency 80%  
Run Hours 00025
```

- **Efficiency** – indicates the efficiency of the heat recovery unit. Initially it displays **80%** at switch on for the first ten minutes to allow the unit time to stabilise, and is updated every 5 seconds to reflect the current heat recovery efficiency of the unit. The screen displays “---“ when off or in standby.
- **Run Hours** – indicates the number of hours that the unit has been operational.

## Maintenance

### Caring for Your Unit

Heat recovery units, by their very nature, require regular maintenance. The Sentinel Totus D-ERV has been designed to facilitate access to enable maintenance to be carried out easily.

In addition to the maintenance tasks outlined below, periodic sterilisation of the unit in line with current medical advice on legionella risks is required. This is contained in a separate leaflet available from Vent-Axia.

### 3-Monthly Maintenance

The following 3-monthly maintenance is recommended:

Table 5: 3-Monthly Maintenance

Item	Action
General	Inspect the unit internally for build-up of dust, dirt and condensation. Clean as required.
Filters	<p>The Status LED on the Commissioning Interface, and on the cable inlet panel, will flash red and green alternately when the filters require replacement. This alarm is triggered by the number of hours that the unit has been running.</p> <p>Replace the filters. Note the filters are NOT washable. Observe the warning label provided on the filters regarding face mask protection and disposal of the used item.</p> <p>When the filter has been replaced, reset the Status LED by following the instructions on the Commissioning Interface Filter screen. This will reset the timer back to <b>2190</b> hours.</p>

### 12-Monthly Maintenance

The following 12-monthly maintenance is recommended:

Table 6: 12-Monthly Maintenance

Item	Action
Heat Exchanger Cell	Inspect the cell for build-up of dust and dirt. Vacuum if necessary.
Motors	Inspect the motors for build-up of dust and dirt on the impeller blades, which could cause imbalance and increased noise levels. Vacuum or wipe clean if necessary.
Condensate Tray	Wipe any wet surfaces with a dilute cleaning solution, such as Milton.
Condensate Drain	Check the condensate drain tube is secure and clear. Clean if necessary.
Allen Bolts	Check that all external Allen bolts are sufficiently tight by using a 5 mm Allen key.

### 5-Yearly Maintenance

The following 5-yearly maintenance is recommended:

Table 7: 5 Yearly Maintenance

Item	Action
Battery	<p>Replace the battery on the Main Controller PCB (type BR1225 3 V). Ensure positive (+) side is uppermost (i.e. visible) when replaced.</p> <p>Adjust the real time clock to agree with the local time. (see <i>Day/Time/Temp/On Off Mode Screen on page 27</i>).</p>

## Troubleshooting

### Diagnosing a Problem

In the event of a problem, always troubleshoot the unit according to:

- **Diagnostic code** displayed on the Commissioning Interface.
- **Fault LED** on the Commissioning Interface and cable entry panel.

If no indications are displayed, then troubleshoot problem according to the fault symptom as described in the following tables.

### Diagnostic Codes

A diagnostic code screen is displayed on the Commissioning Interface in the event that a fault has occurred which resulted in the unit operation being stopped and placed into standby.

**SENTINEL HR**  
**DIAGNOSTIC** ---

The following diagnostic codes may be viewed on the Commissioning Interface.

Table 8: Diagnostic Codes

Problem	Code	Description															
Thermistors	1-255	<table border="0"> <tr> <td>T1</td> <td>T2</td> <td>T3</td> <td>T4</td> <td></td> </tr> <tr> <td>+1</td> <td>+2</td> <td>+4</td> <td>+8</td> <td>= Short Circuit</td> </tr> <tr> <td>+16</td> <td>+32</td> <td>+64</td> <td>+128</td> <td>= Open Circuit</td> </tr> </table> <p>Thermistors are checked continuously and one or more has to be at fault for 60 seconds before triggering this diagnostic stop.</p>	T1	T2	T3	T4		+1	+2	+4	+8	= Short Circuit	+16	+32	+64	+128	= Open Circuit
T1	T2	T3	T4														
+1	+2	+4	+8	= Short Circuit													
+16	+32	+64	+128	= Open Circuit													
Pump float switch open	300	Pump float switch is checked continuously and has to be open (i.e. fault or excess condensate) for 120 seconds before triggering this diagnostic stop. If the unit is 'Off' then pump mains is turned on after 30 seconds to try to reduce the water level.															
Fan 1 extract relay open	310	Fan relays are checked when HR is ON, either relay has to be open for 60 seconds before triggering this diagnostic stop.															
Fan 2 intake relay open	320	Fan relays are checked when HR is ON, either relay has to be open for 60 seconds before triggering this diagnostic stop.															
24 V sensor supply fuse blown	330	24 V sensor supply fuse is checked when the unit is switched on and has to be open for 10 seconds before triggering this diagnostic stop.															
Pressure sensor in CP mode	340	Pressure sensor is checked when HR is ON and in CP mode. The sensor signal has to be below the CP preset threshold ( value from factory test ) whilst the fan speed is greater than 50% for 60 seconds before triggering this diagnostic stop.															
Commissioning Interface but no data from HR	360	A 360 code indicates power to the remote control but no data, a wiring fault or failure on the heat recovery board.															

## Fault LED/Status Relay

A Status relay, provided by the Main Controller PCB, indicates a fault occurring on the unit. A flashing red or red/green LED indicator on the Commissioning Interface, and on the unit cable entry panel, indicate this locally.

The status relay contacts enable remote status monitoring for the fault conditions, which may be connected to an external indicator or BMS, etc. (see *Appendix C: Main Controller PCB Terminals on page 37* for connector details).

Table 9: Fault LED/Status LED Indications

Indication	Possible Problem	Action
Flashing Red	Thermistor failure	Check sensor operation and replace as necessary,
Flashing Red	Condensate sump is full and if the unit is running	Check operation of the float switch and pump. Replace if necessary Check that the pipe carrying the water to the condensate drain is not split, disconnected or kinked. Replace if necessary.
Flashing Red	Fan failure	Check fan operation and replace as necessary,
Flashing Red	24 V sensor supply is shorted or fuse failure	Check sensor operation and replace as necessary,
Flashing Red	Pressure sensor failure	Check sensor operation and replace as necessary,
Flashing Red	Bypass has not reached its intended position	Check whether bypass is motion has stuck or has failed and replace as necessary.
Flashing Red	Commissioning Interface is disconnected or has a fault	Check the connections and cable running between the Main Controller PCB terminals to the Commissioning Interface terminals. Replace/rewire as necessary.
Flashing Red/Green	Filter hours have been exceeded	Replace the filters and reset the Filters commissioning screen (see <i>Filter Screen on page 20</i> ).
Flashing Red	Heating Failure condition	Check heater operation and replace as necessary,
Flashing Red	Shutdown by Defrost Bypass mode	Check bypass operation and replace as necessary,

## Power Supply Troubleshooting

Troubleshoot according to the fault symptoms. If the fault cannot be rectified, contact your local dealer or sales office for a service engineer.

Table 10: Power Supply Troubleshooting

Symptom	Possible Problem	Action
No Power Supply (unit dead)	External Power Supply Failure	Check external power source is available and switched on.
	Distribution Board Input Fuse/RCD	Check fuse, or RCD if used, at distribution board. Replace/reset if necessary.
	Main Controller PCB Fuses	Check fuses on the Main Controller PCB and Power Supply PCB, see <i>Figure 16</i> . Replace if necessary.
	Other	Contact Vent-Axia Technical Support.
No 24 V supply (at sensors/switches)	Fuse F2	Check fuses on the Main Controller PCB and Power Supply PCB, see <i>Figure 16</i> below.
	Main Controller PCB	Contact Vent-Axia Technical Support.

## Internal Fuses

Internal fuse are provided on the Power Supply PCB and the Main Controller PCB for the protection the unit.

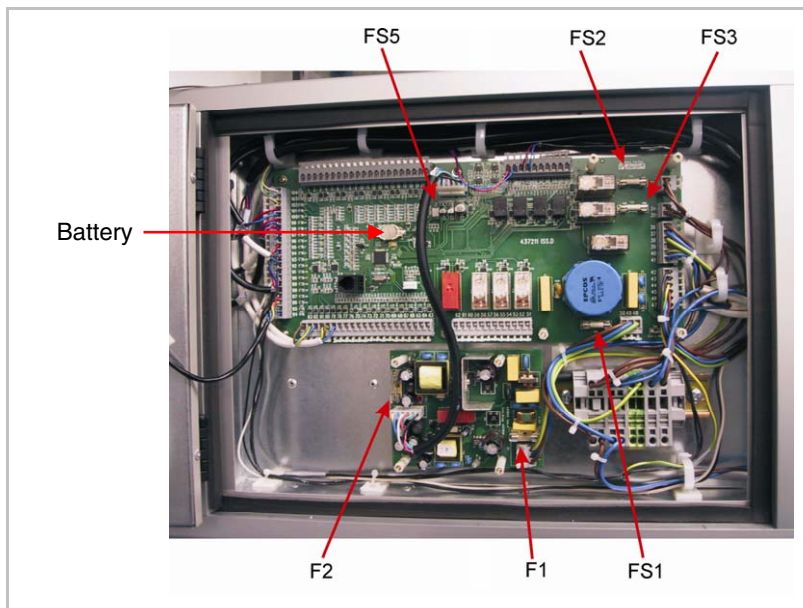

Figure 16: Internal Fuses

The following table lists the fuse values and types.

Table 11: Internal Fuse Values and Types

PCB	Label	Fuse Type	Purpose
Main Controller PCB	FS1	Ceramic 10 A anti-surge	Motors, pump and PSU.
	FS2	Ceramic 10 A anti-surge	Heater 1.
	FS3	Ceramic 10 A anti-surge	Heater 2.
	FS5	Polyfuse 600 mA auto-resetting	Switches, sensors and dampers.
Power Supply PCB	F1	Glass ceramic 500 mA anti-surge	Input supply.
	F2	Glass 1.25 A quick-blow	Main 24 V dc out.

## Airflow/Temperature Troubleshooting

Troubleshoot according to the fault symptoms. If the fault cannot be rectified, contact your local dealer or sales office for a service engineer

Table 12: Airflow/Temperature Troubleshooting

Symptom	Possible Problem	Action
No airflow or Maximum airflow	Settings	Check the Commissioning Interface Status LED and display screens for alarm indications/messages. Check commissioning settings are correct – compare code with that written on the Installer Notice label. Re-instate settings, if necessary.
	Switches/Sensors/Dampers	Check operation of switches, sensors and dampers. Check the unit responds to switch and sensor signals.
	Ducting	Check that ducting has not become loose or disengaged at any point along the airflow.
	Unit	Check airflow entering and leaving the ventilation unit. Check internal fuses, see Figure 16. Replace as necessary. Check operation of motors. Replace if necessary. Restore settings.

## Condensate Troubleshooting

Troubleshoot according to the fault symptoms. If the fault cannot be rectified, contact your local dealer or sales office for a service engineer

Table 13: Condensate Troubleshooting

Symptom	Possible Problem	Action
Condensation water not being pumped out	Trigger switch	Check the operation of the float switch at the corner of the condensate tray. Replace if necessary.
	Pump	Check the operation of the pump. Replace if necessary.
	Pipe	If the switch and pump are both operational, check that the pipe carrying the water to the condensate drain is not split, disconnected or kinked. Replace if necessary.
	Other	Contact Vent-Axia Technical Support.
Pump running continuously	Pump	Check the operation of the float switch inputs. Replace pump if necessary.
	Trigger switch	Check the operation of the float switch. Replace if necessary.

### Appendix A: Glossary

#### Terms and Abbreviations

The following technical terms and abbreviations are used in this manual.

Term/Abbreviation	Description
<b>AQS</b>	Air Quality Sensor
<b>BMS</b>	Building Management System
<b>CO<sub>2</sub></b>	Carbon Dioxide
<b>CP</b>	Constant Pressure
<b>D-ERV</b>	Demand Energy Recovery Ventilation
<b>EC/DC</b>	Electrically Commutated Direct Current motor
<b>EEPROM</b>	Electrically Erasable-Programmable Read-Only Memory
<b>HRU</b>	Heat Recovery Unit
<b>LCD</b>	Liquid Crystal Display
<b>LED</b>	Light Emitting Diode
<b>Min/Max</b>	Minimum (trickle)/Maximum (boost)
<b>P-Band</b>	Proportional Control Range
<b>PC</b>	Proportional Control
<b>PCB</b>	Printed Circuit Board
<b>PID</b>	Proportional Integral Derivative control
<b>RCD</b>	Residual Current Device
<b>SELV</b>	Separated Extra-Low Voltage. IEC 61140 defines a SELV system as "an electrical system in which the voltage cannot exceed ELV under normal conditions, and under single-fault conditions, <i>including</i> earth faults in other circuits".
<b>T<sub>1</sub></b>	Temperature of the fresh ambient air entering the unit from outside
<b>T<sub>2</sub></b>	Temperature of the fresh air entering the room (supply)
<b>T<sub>3</sub></b>	Temperature of the stale air leaving the room (exhaust)
<b>T<sub>4</sub></b>	Temperature of the stale air discharged to the outside ambient
<b>T<sub>c</sub></b>	Comfort setting
<b>PIR</b>	Passive Infra-Red Sensor
<b>VFC</b>	Voltage-Free Contact

### Appendix B: Options and Accessories

#### Sentinel Totus

The following options and accessories are available for the Sentinel Totus.

No	Item	Control Type	Part Number	Description
<b>Sensors and Switches</b>				
1.	Air Quality Sensor (AQS)	Switch	432953	<ul style="list-style-type: none"> <li>Measures VOC level (adjustable)</li> <li>Adjustable run-on timer 1-25 min</li> </ul>
2.	Passive Infra-red Sensor (PIR)	Switch	433162	<ul style="list-style-type: none"> <li>Person detection</li> <li>Adjustable run-on timer 5-25 min</li> </ul>
3.	Humidity Switch	Switch	432949	<ul style="list-style-type: none"> <li>Adjustable humidity sensing level 65 – 90%</li> </ul>
4.	Ambient Response Humidistat	Switch	432945	<ul style="list-style-type: none"> <li>Fixed humidity sensing at 72/75% RH</li> <li>Incorporates night setback</li> </ul>
5.	Time switch	Switch	563515	<ul style="list-style-type: none"> <li>7/24 mechanical type</li> <li>Maximum 6 cycles/day</li> </ul>
6.	Thermostat	Switch	563502B	<ul style="list-style-type: none"> <li>Adjustable 6-30° C</li> </ul>
7.	Remote Speed Control	Variable	426332	<ul style="list-style-type: none"> <li>Manual fan motor speed control (24 V dc)</li> </ul>
8.	Carbon Dioxide	Variable	433257	<ul style="list-style-type: none"> <li>Control level settable up to 2000 ppm CO<sub>2</sub> and 50° C</li> <li>24 V dc</li> </ul>
9.	Carbon Dioxide Duct Probe	Variable	433259	<ul style="list-style-type: none"> <li>Control level settable up to 2000 ppm CO<sub>2</sub></li> <li>24 V dc</li> </ul>
10.	Remote Fan Status Indicator	Visual Display	433816	<ul style="list-style-type: none"> <li>Indicates fan running condition OK. Will flag fan failure.</li> </ul>
<b>Constant Pressure</b>				
11.	Power Supply	24 V dc	433193	<ul style="list-style-type: none"> <li>24 W maximum output</li> </ul>
12.	Damper Assembly	MIN-MAX positioning	DVD100/MM to DVD315/MM	<ul style="list-style-type: none"> <li>Sizes 100 – 315 mm</li> <li>24 V dc actuator</li> </ul>
13.	Damper Assembly	Proportional 0-10 V	DVD100/PCM to DVD315/PC	<ul style="list-style-type: none"> <li>Sizes 100 – 315 mm</li> <li>24 V dc actuator</li> </ul>
14.	PIR Grille Kit	PIR/Humidity controlled damper	434184	<ul style="list-style-type: none"> <li>125 mm size ducting</li> <li>12 V ac transformer supplied with kit</li> <li>Mechanical humidity control included</li> </ul>
<b>Roof Mounting</b>				
15.	Cowl (Mini/Midi)		441205	<ul style="list-style-type: none"> <li>Weatherproof cowl (small/medium)</li> </ul>
16.	Cowl (Maxi)		441336	<ul style="list-style-type: none"> <li>Weatherproof cowl (large)</li> </ul>

### Appendix C: Main Controller PCB Terminals

#### Terminals

The following table details the terminals on the Main Controller PCB.

Terminal No.	Name	Description
1-3	-	Factory use only
4-6	CO <sub>2</sub> Internal 0-10 V	24 V supply available to sensor, 0-10 V sensor input
7- 9	Proportional Temp 0-10 V	24 V supply available to sensor, 0-10 V sensor input
10-12	Proportional CO <sub>2</sub> 0-10 V	24 V supply available to sensor, 0-10 V sensor input
13-15	Proportional Humidity 0-10 V	24 V supply available to sensor, 0-10 V sensor input
16-18	Remote/Local 0-10 V	24 V supply available to sensor, 0-10 V sensor input
19-21	BMS Proportional 0-10 V	24 V supply available to sensor, 0-10 V sensor input
22-25	-	Factory use only
26-28	Damper 1	Open – 24 V (on) when HR is on and dampers are opening Close – 24 V (on) when HR is on and dampers are closing
29-31	Damper 2	Open – 24 V (on) when HR is on and dampers are opening Close – 24 V (on) when HR is on and dampers are closing
32-50	-	Factory use only
51-53	Air Conditioning Enable	On when <HR time clock or switch enable or always on > is on Off when HR is off Off when running in Overheat mode
54-56	Heater Interlock Enable	On when <HR time clock or switch enable or always on > is on Off when HR is going off – fans run for run on time Off when running in Overheat mode
57-59	Filter	On when HR is on and filter time has elapsed Off when HR is off Off when HR is on and filter time has not elapsed
60-62	Status	On when HR is on Off for a fault condition. The Status LED flashes red when the relay is off. <i>See Table 9: Fault LED/Status LED Indications on page 32</i>
63-65	Switch 5 BMS Enable	Closed = HR on, Open = HR off
66-68	Switch 4 Central Heating	Closed = heating off (enables Overheat), Open = heating on
69-71	Switch 3 Min-Max 24 V	Closed = max speed, Open = min speed
72-74	Switch 2 Min-Max 24 V	Closed = max speed, Open = min speed
75-77	Switch 1 Enable On/Off	Closed = HR on, Open = HR off
78-83	-	Factory use only
84-87	Commissioning Interface Connection	PCB terminals 1-4 connect to the Commissioning Interface terminals 1-4



## Declaration of Conformity

# **Vent-Axia**

Head Office: Fleming Way, Crawley, West Sussex, RH10 9YX. Tel: 01293 526062 Fax: 01293 551188

**UK NATIONAL CALL CENTRE**, Newton Road, Crawley, West Sussex, RH10 9JA

SALES ENQUIRIES: Tel: 0844 8560591 Fax: 01293 534898

TECHNICAL SUPPORT Tel: 0844 8560595 Fax: 01293 455197

For details of the warranty and returns procedure please refer to [www.vent-axia](http://www.vent-axia) or write to Vent-Axia Ltd, Fleming Way, Crawley, RH10 9YX