komfovent[®]

Air handling units control computer program (software)

VENTILATION CONTROL SYSTEM

User Manual



TABLE OF CONTENTS

INTRODUCTION.....	3
OBJECTS CREATION.....	3
OBJECTS OBSERVATION.....	8
“OFFLINE” MODE	9
UNIT CONTROL	10
TROUBLESHOOTING	14

INTRODUCTION

Air handling units' computer control program is intended for maintenance and to control air handling units installed in the building. Air handling units may be connected by special modems to local net or internet and provided with IP addresses and *Ventilation Control System* visualization program gives possibility to monitor from the operator computer running processes such as: temperatures, ventilation intensities, operation modes and to control air handling units operation: to switch on and off the unit, to change ventilation intensity, to set operation mode and so on, also to indicate failures.

OBJECTS CREATION

Every air handling units has its name, constructional features and identification number called as IP address in the computer control system when connected to net, therefore to identify the units all these data must be entered to the computer control program.

1. Open main program window, press button **NEW** to create new object.

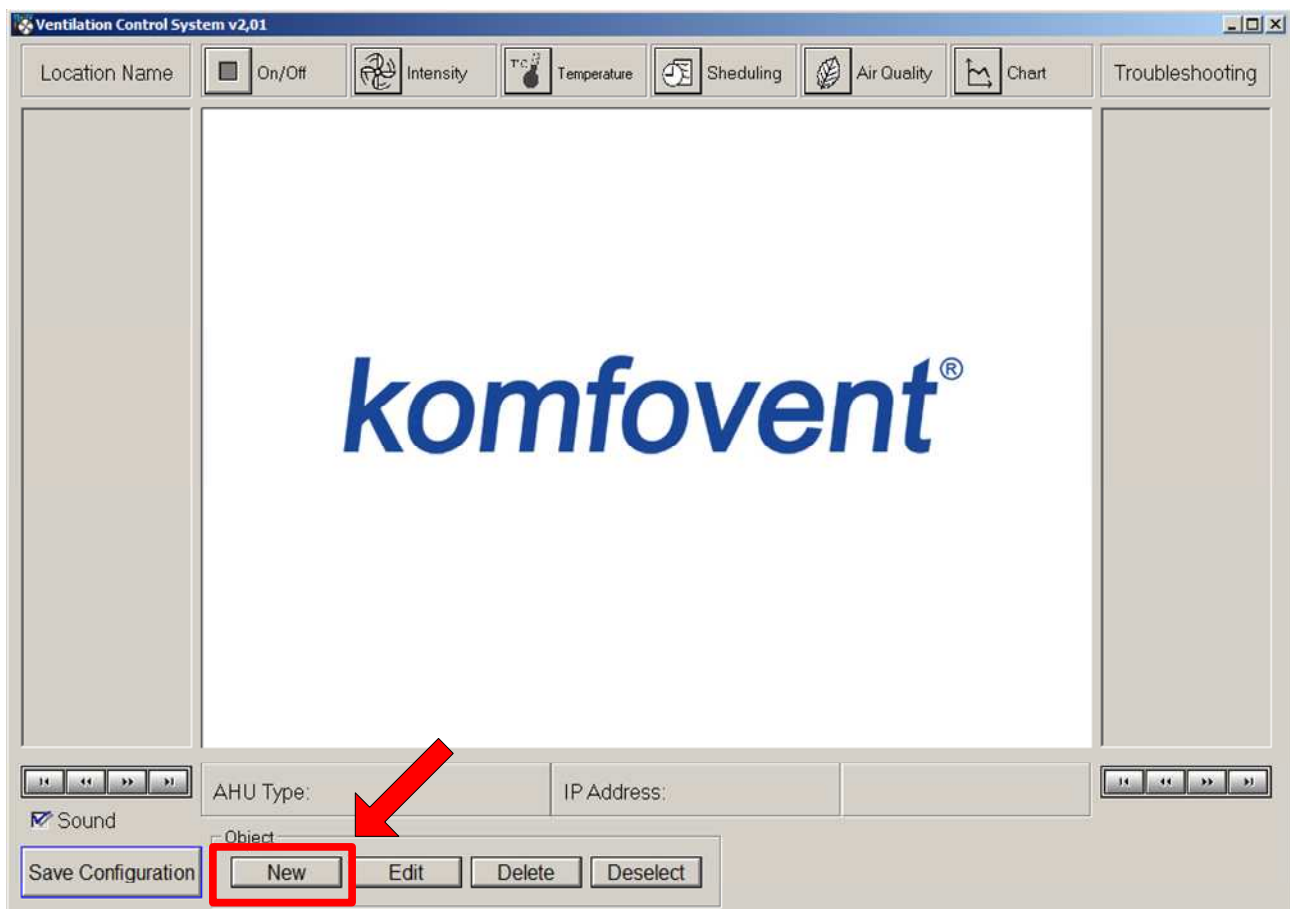

2. In the opened program window **Edit Object Data** main unit data must be entered:

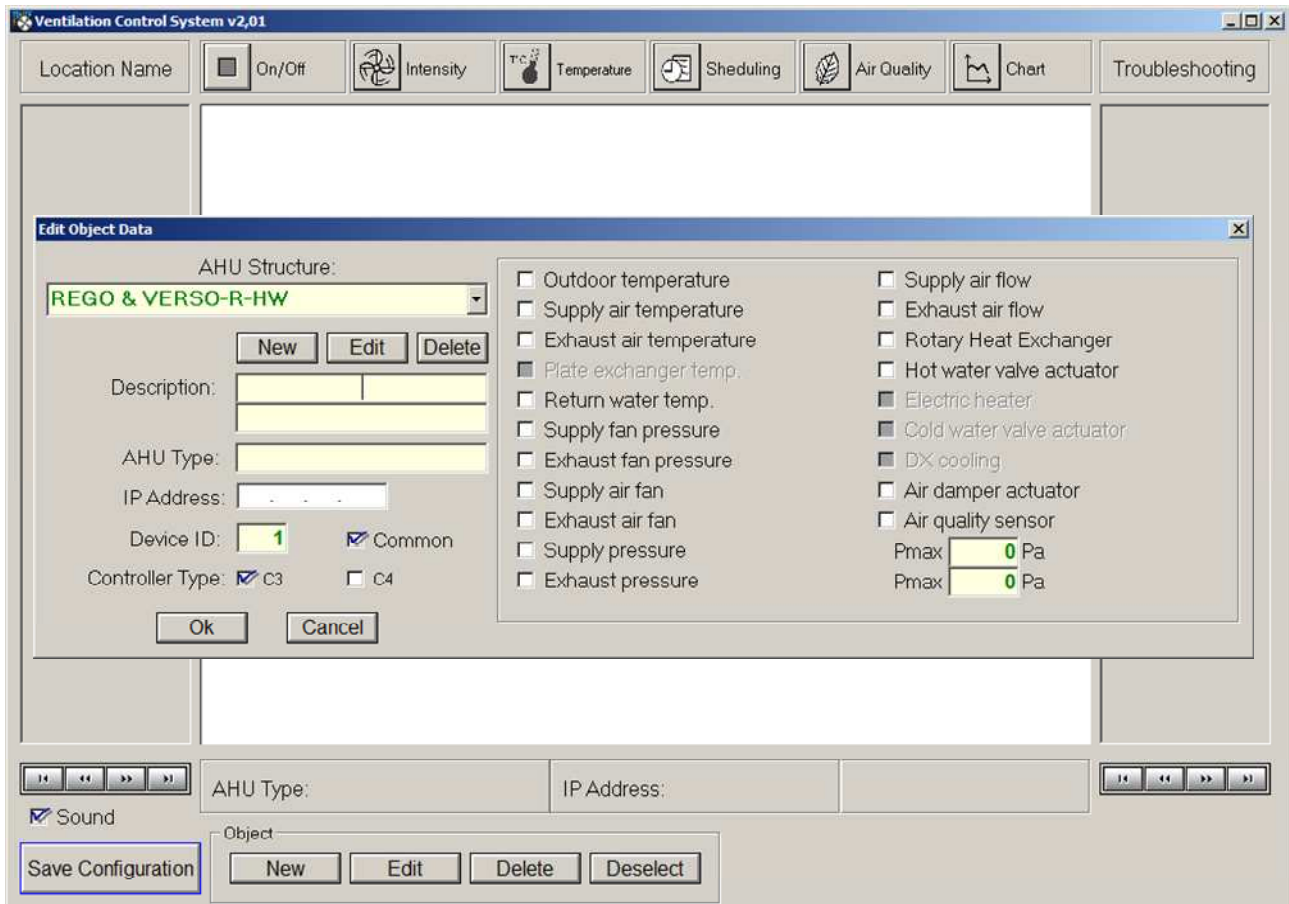

2.1. **AHU Structure** – enter unit type:

REGO / VERSO-R – air handling unit with rotary heat exchanger;
 RECU / VERSO-P – air handling unit with plate type heat exchanger;
 OTK / VERSO-S – air supply unit;
 HW – air handling unit with water heater;
 HE – air handling unit with electric heater;
 CW air handling unit with water cooling;
 DX – air handling unit with DX cooling;
 MS – air handling unit with air mixing section.

2.2. In the **Description** field enter name of the premises which are ventilated by this air handling unit, for example: “Conference Hall No.1”

2.3. In the field **AHU Type unit** name can be entered, for example: “VERSO-R-30”

2.4. **IP Address** – enter provided for unit computer net address.

2.5. **Device ID** – when several units are operating with one modem, corresponding unit’s identification number must be indicated (entered) in the computer control system. If every unit has separate modem, value in the window must be left as it is and **Common** field must be activated.

Device ID: Common

2.6. At the bottom of the window controller type must be chosen:

Controller Type: C3 C4

2.7. Then on the right window part depending on unit type and automation possibilities must be indicated required for monitoring data, components and their parameters:

- ✓ Outdoor temperature [°C];
- ✓ Supply air temperature [°C];
- ✓ Exhaust air temperature [°C];
- ✓ Plate exchanger temperature [°C];
- ✓ Return water temperature [°C];
- ✓ Supply fan pressure [Pa];
- ✓ Exhaust fan pressure [Pa];
- ✓ Supply air fan [%];
- ✓ Exhaust air fan [%];
- ✓ Supply pressure [Pa];
- ✓ Exhaust pressure [Pa];
- ✓ Supply air flow [m³/h];
- ✓ Exhaust air flow [m³/h];
- ✓ By-pass damper actuator [%];
- ✓ Rotary heat exchanger [%];
- ✓ Hot water valve actuator [%];
- ✓ Electric heater [%];
- ✓ Cold water valve actuator [%];
- ✓ DX cooling [%];
- ✓ Air damper actuator [on/off];
- ✓ Air quality sensor [%];

Note: In order to indicate supply and exhaust air pressure in the ducts for unit with C3 controller and VAV (variable air volume) function, **Supply pressure** and **Exhaust pressure** windows must be activated, and maximum pressure **Pmax** of duct sensors must be indicated:

Supply pressure Exhaust pressure

Pmax	<input type="text" value="150"/>	Pa
Pmax	<input type="text" value="150"/>	Pa



2.8. After entering all data and going through the settings, unit is activated by tapping in Ok:

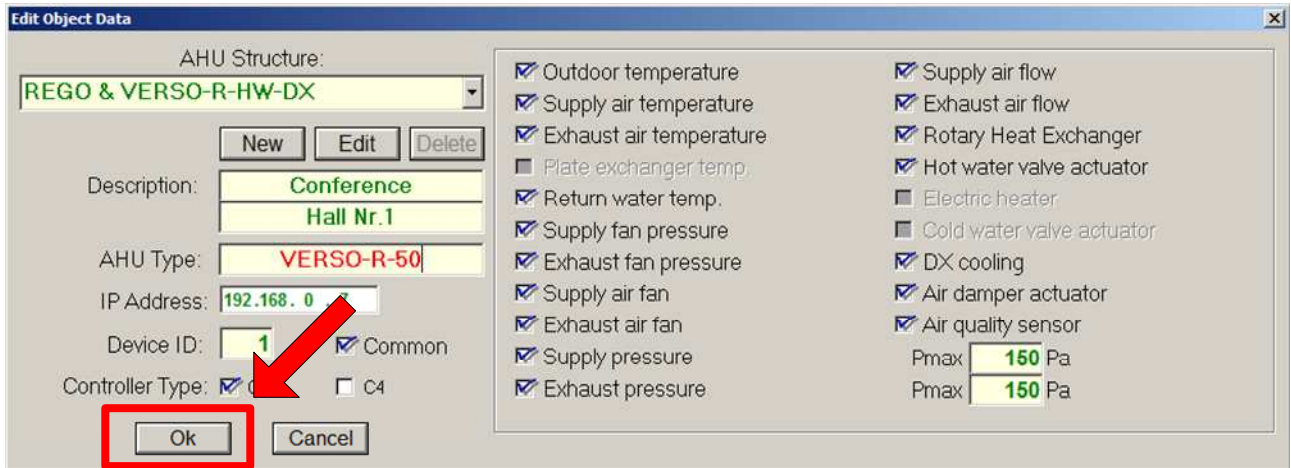

3. Newly created object appears in the left side of the main program window:

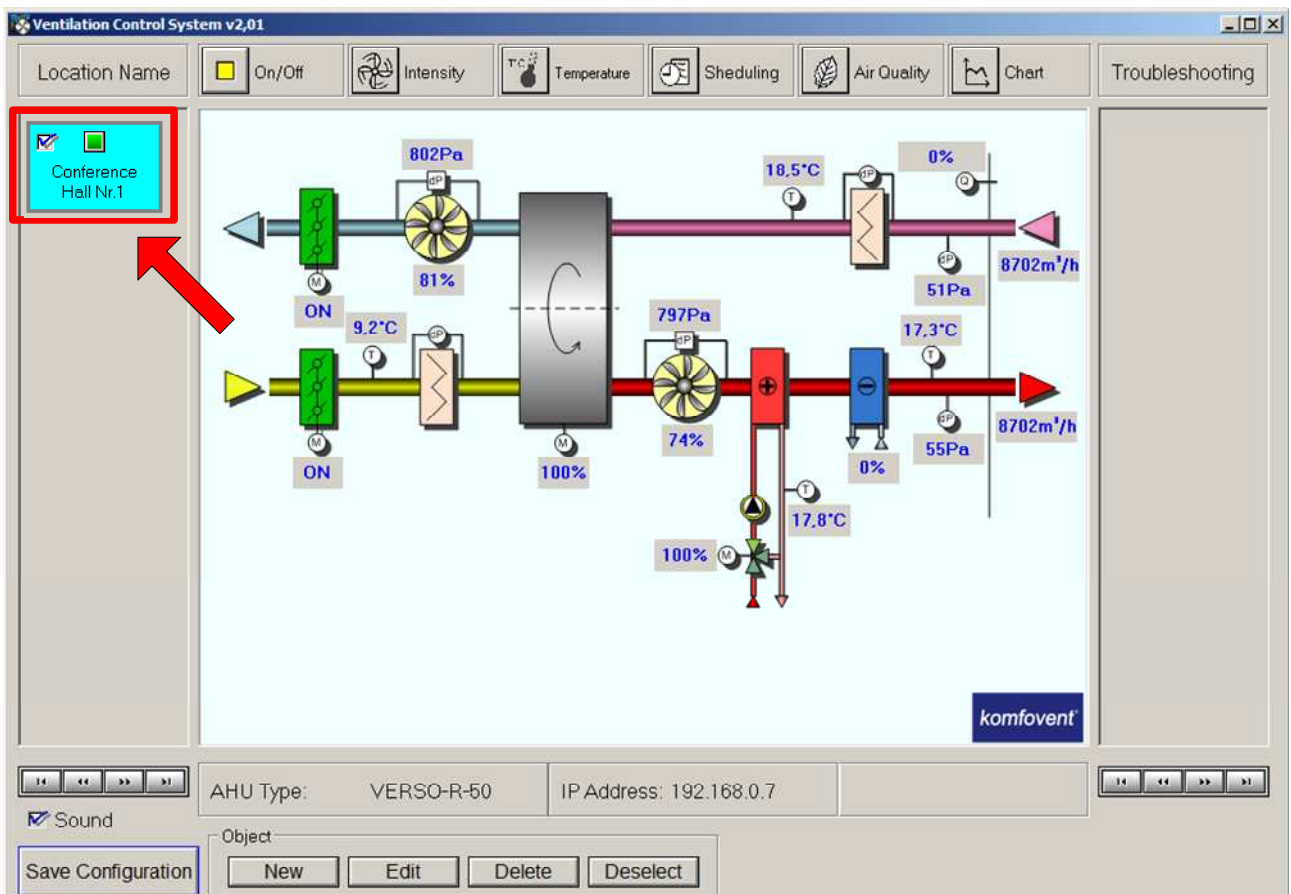

For the next object creation **New** button must be pressed again and all procedures listed in clause 2 must be analogically performed. To correct already entered data for created object press **Edit** button, to delete the object – use **Delete** button.

After creation the object and entering required data, **Save Configuration** button must be pressed:

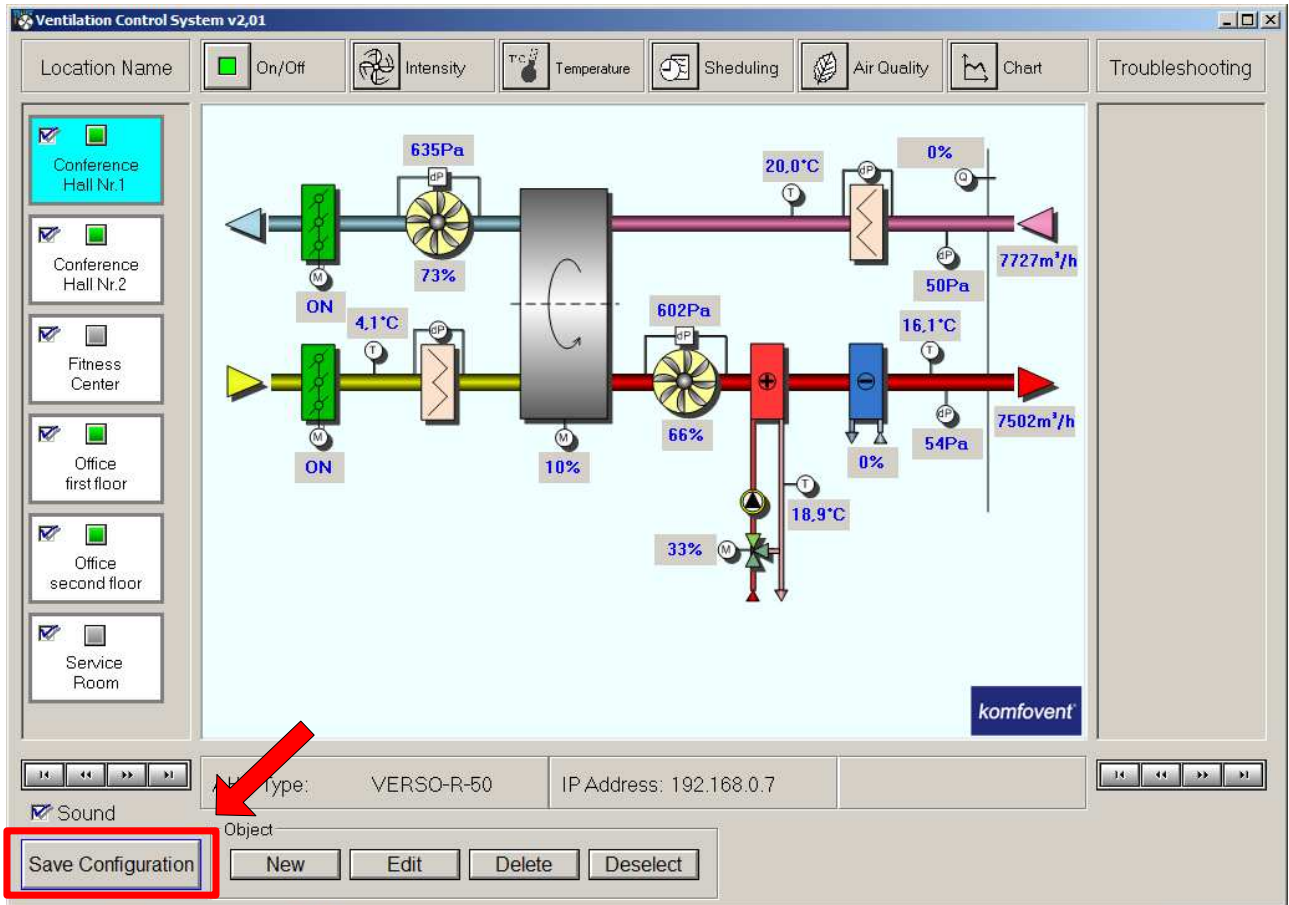

OBJECTS OBSERVATION

In the section **Location Name** of the main program window every created object can be revised, i.e. operation of air handling unit of corresponding premises (which names were previously created) can be observed. By pressing mouse left button holding on the name of the premises, selected object is marked with blue color, and functional scheme of air handling unit appears in the central window part:

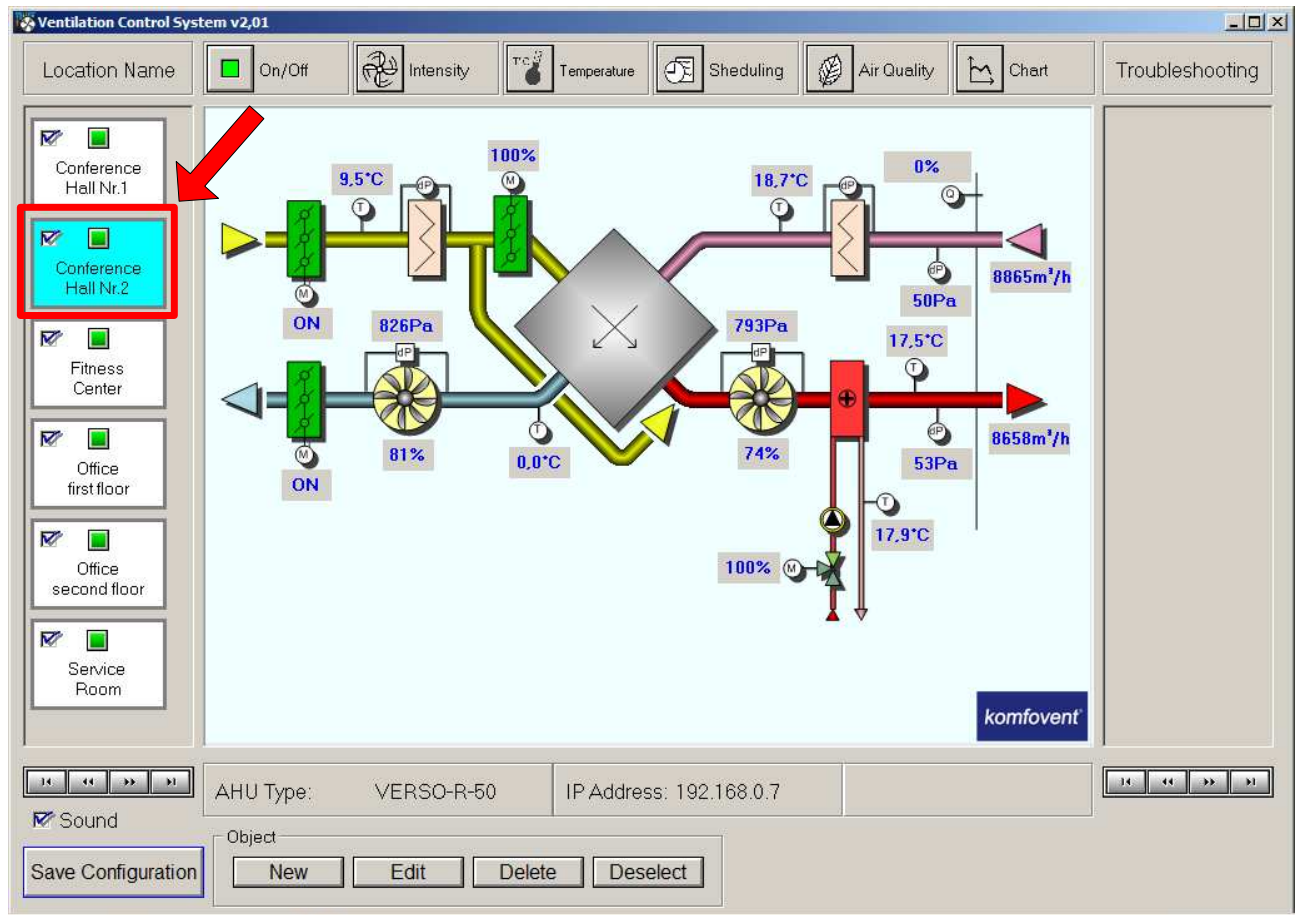

Shifting from one object (unit) to another is done by pressing mouse button on the required premises name. If there are more than 6 objects and they do not fit in section **Location Name** window, rest created objects can be revised using the bottoms located in the bottom of this window.

Note:



Indication showing unit operation.

Mark indicating that air handling unit's data reading is activated.

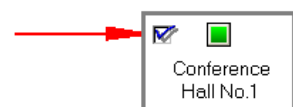

“OFFLINE” MODE

If unit activating is on (see before) and if by data reading process connection between unit and PC is interrupted not once, then after several interruptions during certain time period not restored, air handling unit will switch to “Offline” mode automatically. Program will stop displaying data and object will be marked with yellow colour:

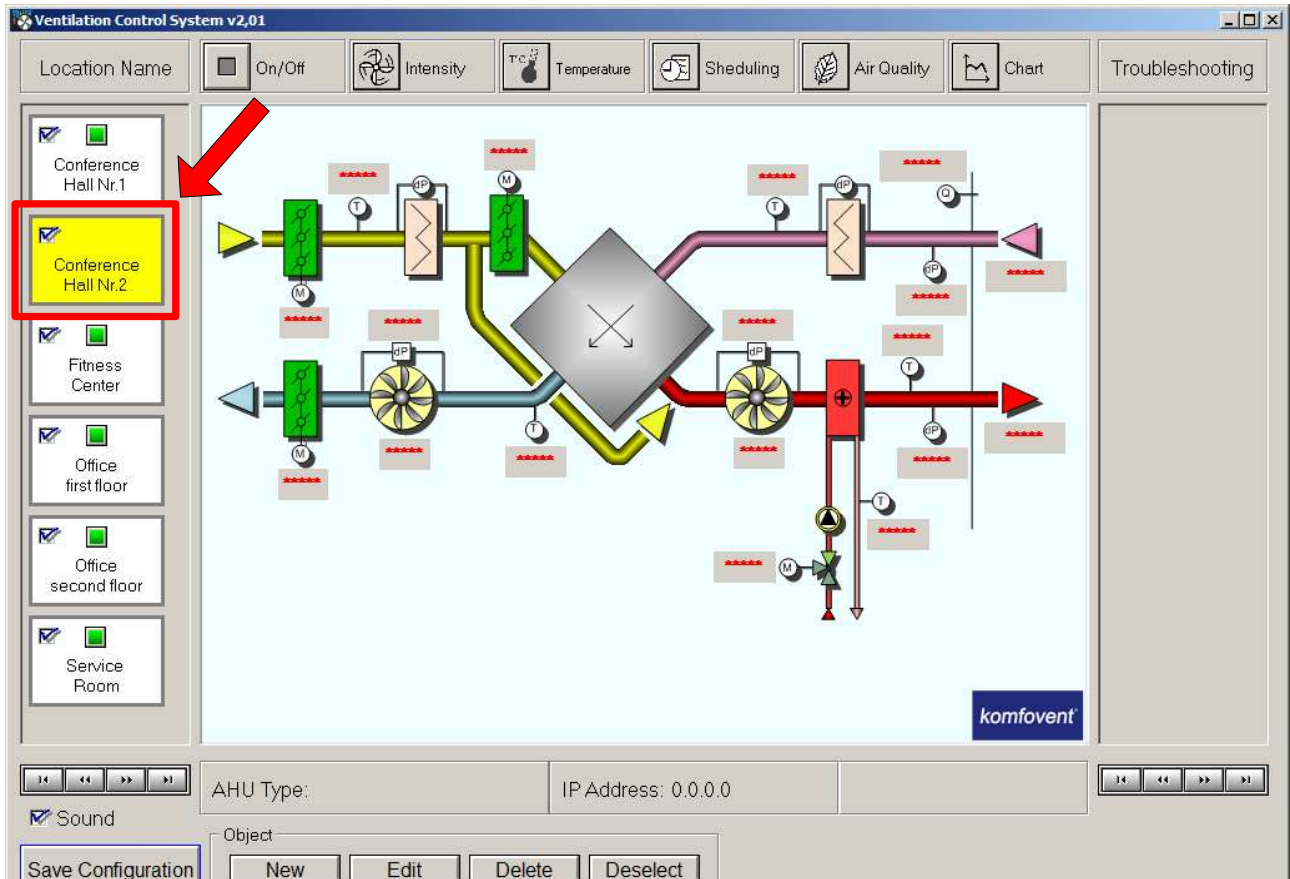

After network failure is eliminated, “Online” mode must be actuated in order to restore connection with the air handling unit. Restart data reading for that, i.e. remove and denote marking of data reading activation again:

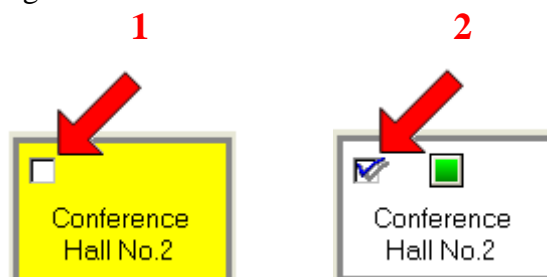

Note: After restarting the program *Ventilation Control System* all objects will switch to “Online” mode automatically.

UNIT CONTROL

By choosing ventilated premises in section **Location Name**, it is possible not only to observe and monitor, but also to control air handling unit operation. In the program window upper part is designed main settings and control menu:

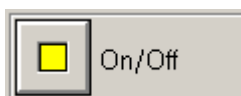
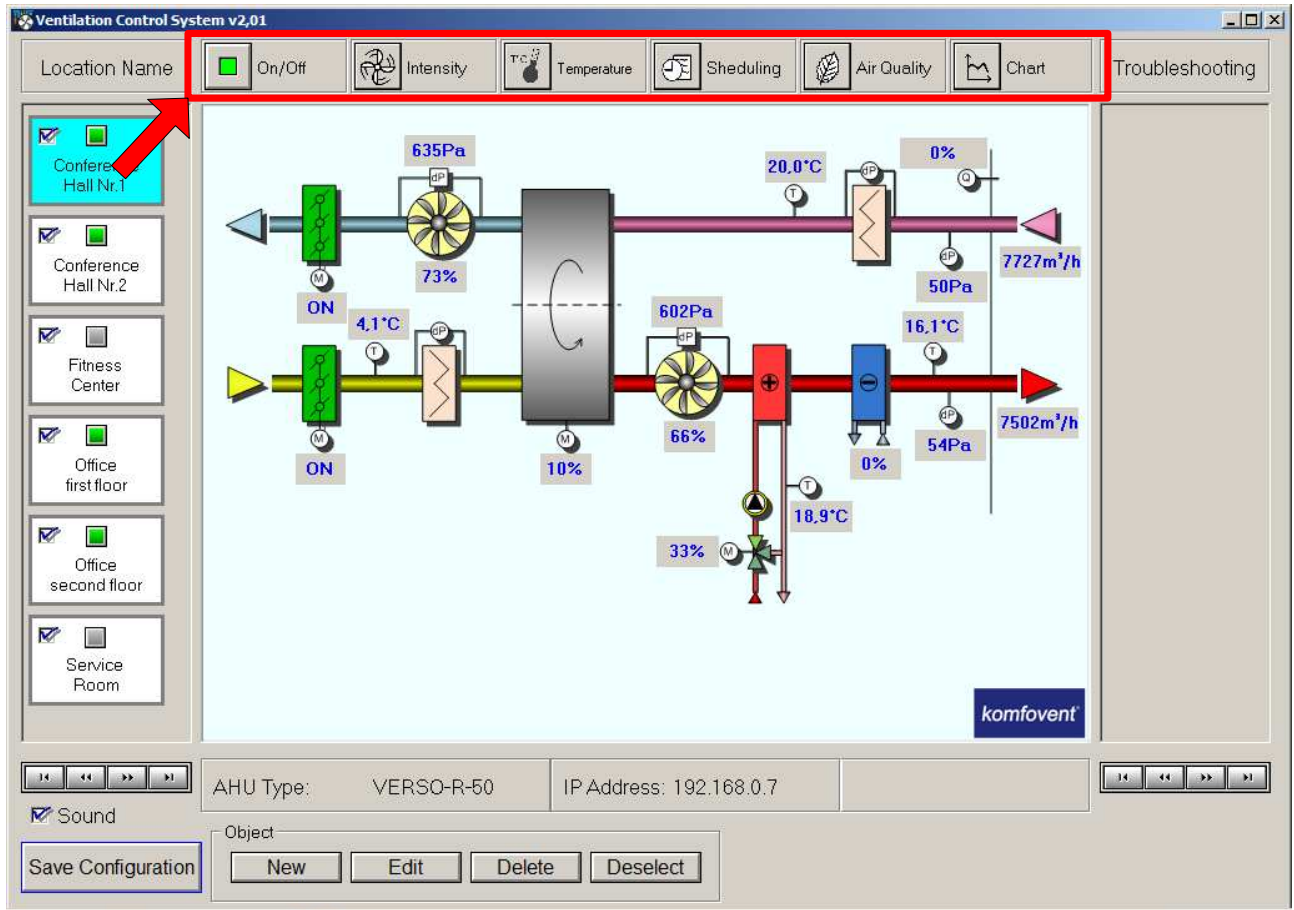

1. Unit turning on and off

On/Off button indication:



- unit is off



- unit is on and works in manual mode



- unit is on and works in auto mode by weekly program



2. Ventilation intensity settings

Intensity Level – settings of ventilation intensity level: 1, 2, 3;

Actual Level – indication of unit actual ventilation level

Flow Adjusting – intensity adjusting for each ventilation level;

Flow Control Mode – selection between constant air flow (CAV) and variable air flow control (VAV);

Exhaust Flow Correction – correction of exhaust air flow (-50...+50%) for time period (1 ... 99 min.);

„OVR“ Intensity Adjusting – „OVR“ function setting for supply air and exhaust air fans.

Intensity

Intensity Level: Actual Level: **3**

Flow Adjusting:	Supply Air	Exhaust Air
I	<input type="text" value="40"/> %	<input type="text" value="40"/> %
II	<input type="text" value="60"/> %	<input type="text" value="60"/> %
III	<input type="text" value="90"/> %	<input type="text" value="90"/> %

Flow Control Mode:

Exhaust Flow Correction: Enabled Value: % Time: min

"OVR" Intensity Adjusting:	Supply Air	Exhaust Air
	<input type="text" value="20"/> %	<input type="text" value="90"/> %

OK Cancel



3. Temperature settings

Set Temperature – temperature setpoint (15...30°C);

Temperature Mode – temperature maintenance mode selection: SUPPLY, ROOM or AUTO;

Season – unit mode selection: SUMMER, WINTER or AUTO;

Temperature Correction – temperature setpoint value correction (-9...+9°C) for time period

Air Recirculation – activation of recirculation for time period (only for units with air mixing section)

Temperature

Set Temperature: °C

Temperature Mode:

Season:

Temperature Correction:	Value	Start	Stop
	<input type="text" value="0"/> °C	<input type="text" value="8:00"/> h	<input type="text" value="18:00"/> h

Air Recirculation:	Start	Stop
<input type="checkbox"/> Enabled	<input type="text" value="7:00"/> h	<input type="text" value="18:00"/> h

Ok Cancel



4. Weekly program settings

Enabled – unit operation activation according weekly time program;
Event #1, 2, 3 – selection of day event;
Sunday
Monday
Tuesday
Wednesday – week days;
Thursday
Friday
Saturday
Set Time – time setting according PC

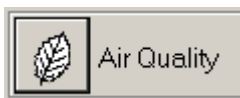

5. Air quality settings

Enabled – air quality function activation;
Sensor Type – air quality sensor selection;
Air Quality 1 [0...100%] – air quality sensor having signal-dependent linear relationship, the maximum value of output signal corresponds to the highest air quality;
Air Quality 2 [100...0%] – air quality sensor having inverse relationship, the maximum value of output signal corresponds to lowest air quality;
Air Humidity [0...100%] – relative humidity sensor;
CO₂ [0...2000ppm] – CO₂ quantity sensor;
Setpoint – maintenance value setting.

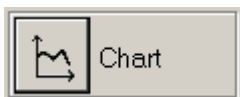

6. Parameters monitoring

In the opened chart window parameters required for monitoring must be selected, then must be marked monitoring interval **Day** or **Week** and drawing is started by pressing **On/Off** button. Information will be presented in graphical chart till the chart drawing is activated. To stop charting **On/Off** button must be pressed and to clear the window – use **Clear** button:

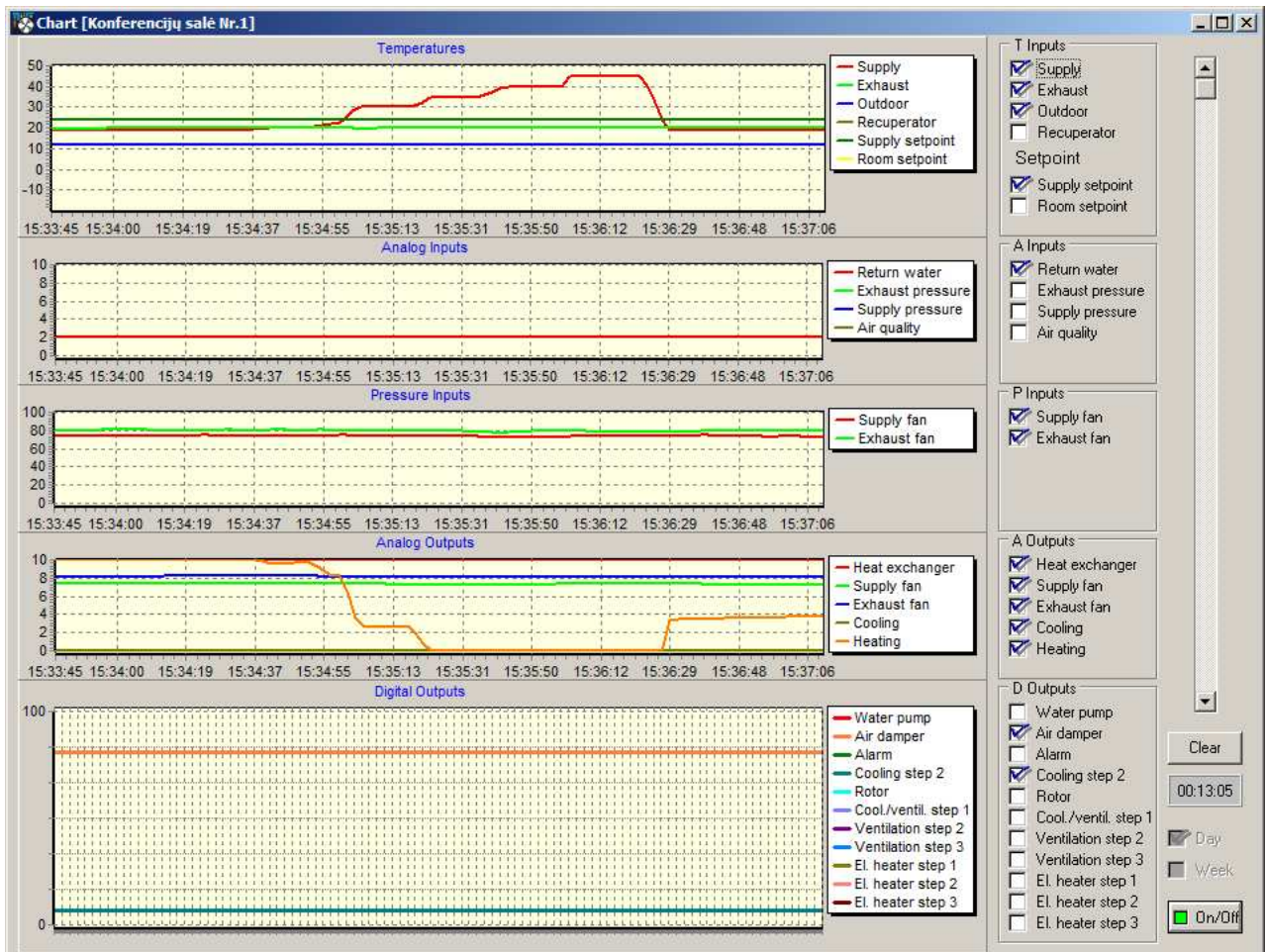

Important: simultaneously it is possible to monitor and graphically present parameters only of one selected air handling unit.

TROUBLESHOOTING

Every unit failure is indicated in the right side of the main program window. In case of failure in **Troubleshooting** section ventilated premises name appears:

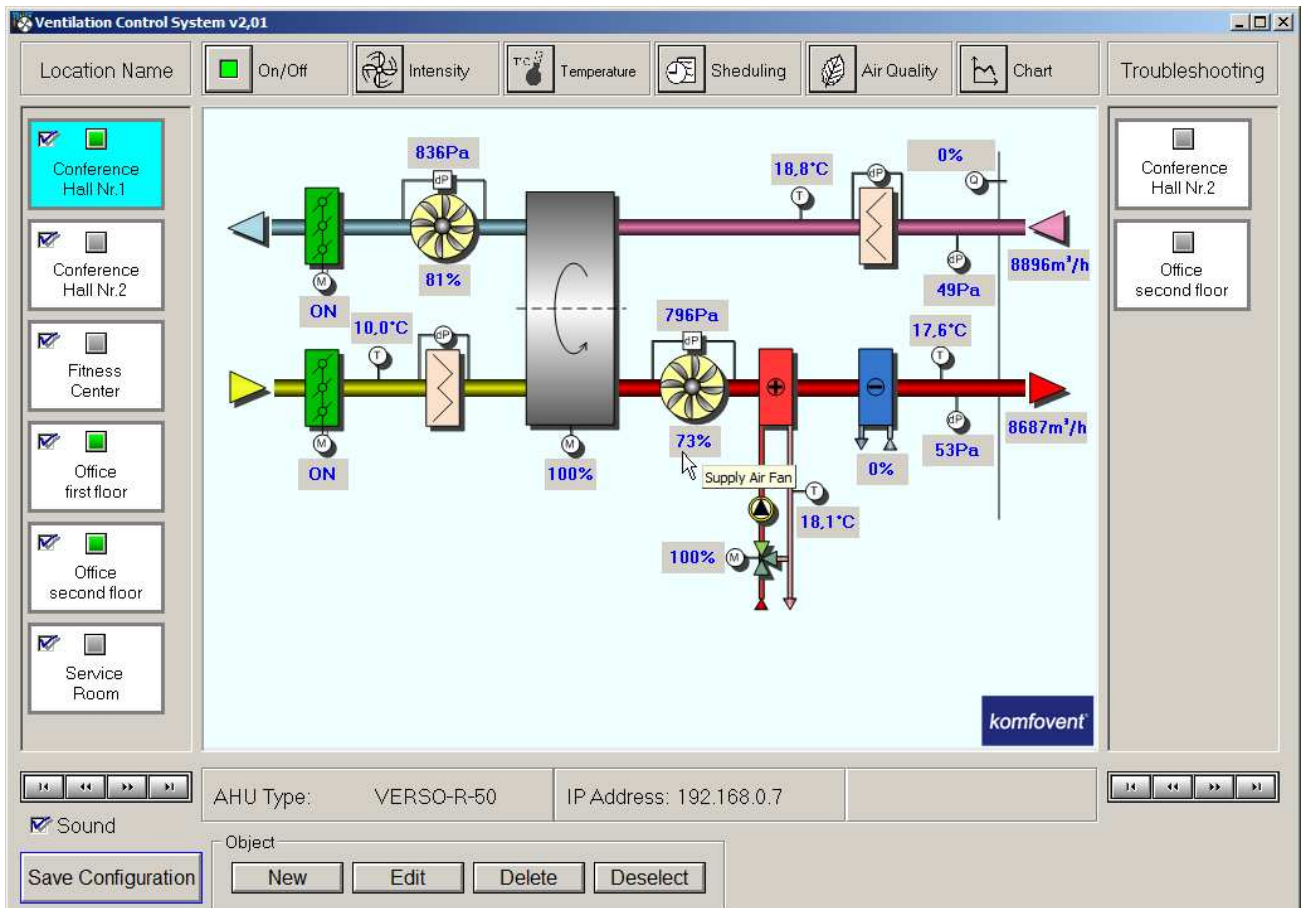

Appearance of every failure will be accompanied by sound signal, which can be turned off after confirmation by pressing any keyboard button.

Switch off sound failure signalization by removing **Sound** mark, if this function is not required:



By pressing mouse left button on the appeared in the right side premises name, functional scheme of the air handling unit with failure will appear.

At the bottom of unit functional scheme last failure message is displayed:

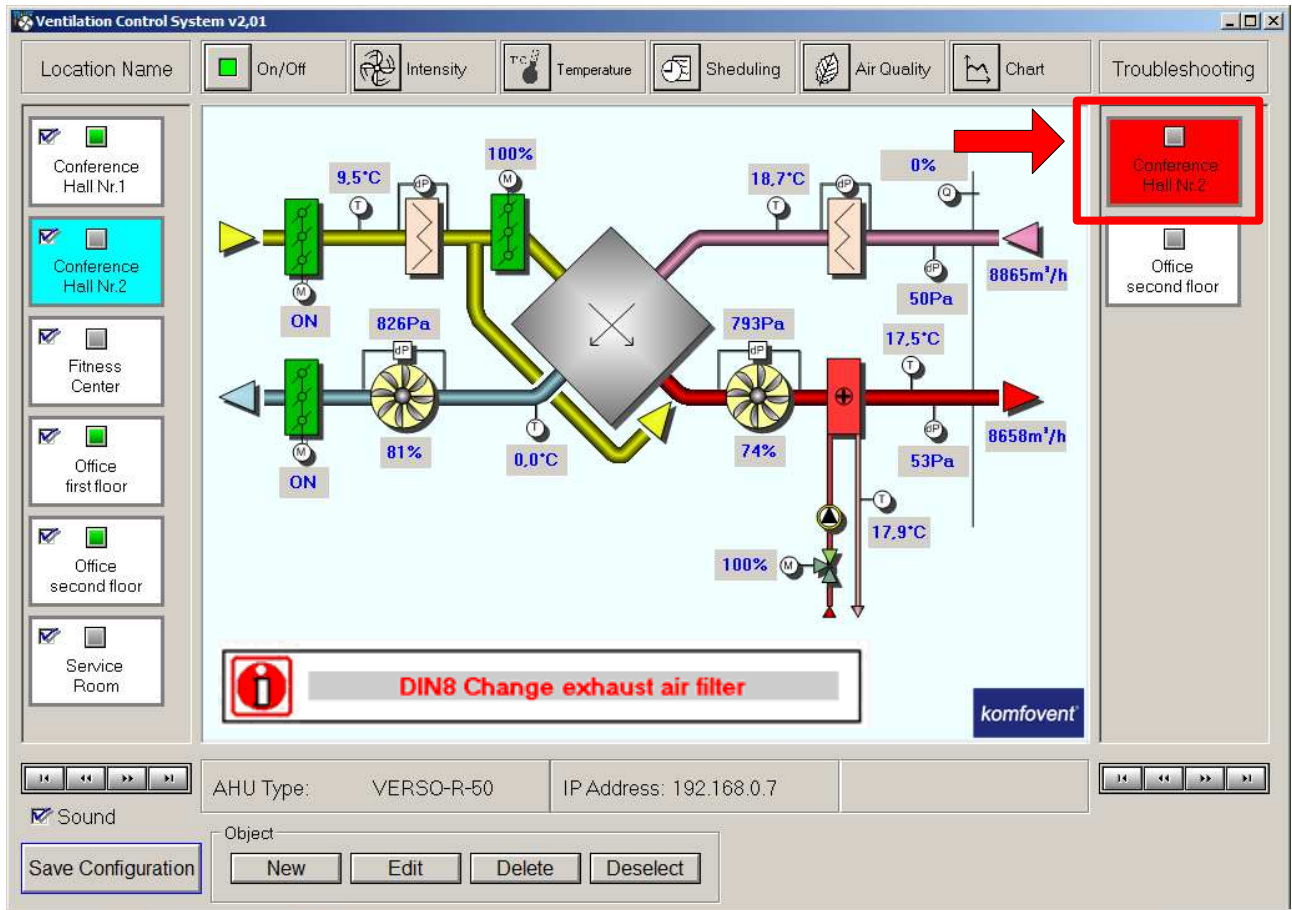

All possible fault causes are described in the table below:

Table 1. Displayed unit failures messages

Message
Change supply air filter
Change exhaust air filter
Low supply air temperature
Supply air overheating
Supply air fan overheating
Exhaust air fan overheating

Continued Table 1. Displayed unit failures messages

Message
Return water low temperature
Electric heater overheating
Heater off
Frost possibility
Rotor stopping
Fire alarm
Sensor error

Note: More detailed faults description, their possible causes and ways of elimination are presented in the automatic control instruction manual.