



# **VERSO-P, VERSO-R**

Series Air Handling Units with C3 Control System  
Electrical Installation and Operation Manual

<b>1. INSTALLATION MANUAL</b>	<b>3</b>
1.1. Air Handling Units Sections Connection	3
1.2. Electric Power Supply Connection	3
1.3. External Elements Connection	4
1.4. Temperature Sensors Installation	5
1.5. Control Panel Installation	5
<b>2. OPERATION MANUAL</b>	<b>6</b>
2.1. Unit Control	6
2.2. Switching on the Unit	6
2.3. Control Panel Indication	7
2.4. Parameters Review	8
2.5. Quick Ventilation Level Switchover	8
2.6. Unit Programmable Settings	8
2.7. Other Control Functions	13
2.8. Unit PC control	14
2.9. Troubleshooting	14
<b>Unit Functional Diagrams</b>	<b>16</b>
<b>Specification</b>	<b>18</b>
<b>Wiring Diagram</b>	<b>19</b>

# 1. INSTALLATION MANUAL

Installation works can be performed only by the specialists that have required qualification. During installation following requirements must be fulfilled.

 It is recommended to lay control cables separately from power cables, or use shielded cables. In such case it is necessary to earth cable shielding!

## 1.1. Air Handling Units Sections Connection

After unit parts have been connected together (see unit installation instruction), unit sections connecting cables and wires are connected.

 Connector connection is performed strictly according to numeration given in wiring diagram, or adequate markings (see unit electric scheme).

 When disconnecting unit sections, do not pull by connecting wires and cables!

## 1.2. Electric Power Supply Connection

It is necessary to connect earthing! When unit is equipped with electric heater, there is a need to connect additional supply to each heaters section main switch.

Unit and electric heater supply cable is selected according to given maximum current in the technical data pages.

Cable types are shown in the 1.2 Table:

1.2 Table

**Electrical Power Supply Cable Types**

Current, A	Cable Type
15	5 x 1,5 mm <sup>2</sup> (Cu)
21	5 x 2,5 mm <sup>2</sup> (Cu)
27	5 x 4,0 mm <sup>2</sup> (Cu)
34	5 x 6,0 mm <sup>2</sup> (Cu)
50	5 x 10,0 mm <sup>2</sup> (Cu)
70	5 x 16,0 mm <sup>2</sup> (Cu)
85	5 x 25,0 mm <sup>2</sup> (Cu)

Unit must be connected to the stationary installation by solid cable through circuit breaker with 300mA current leakage protection.

 Before connecting unit to the electrical power supply, it is necessary to check whether earthing has been installed properly.

### 1.3. External Elements Connection

On the air handling unit wall it is provided connection box. To the terminals which are inside the box (1.3 Picture) all external control elements are connected.

External elements connection diagram is given in the 1.3a Picture.

1.3 Picture

**Connection Board C3-P1**

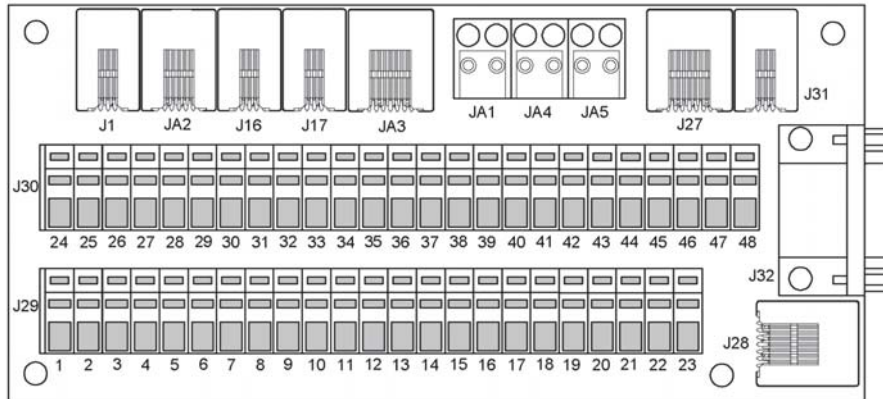

If the unit has PC control function, computer network (“Ethernet”) or Internet is connected to the connection board socket J28. There is an option to connect computer with RS-232 interface to the socket J32 (more detailed description is given in the 2.8. chapter).

1.3a Picture

**Control System External Elements Connection Diagram**

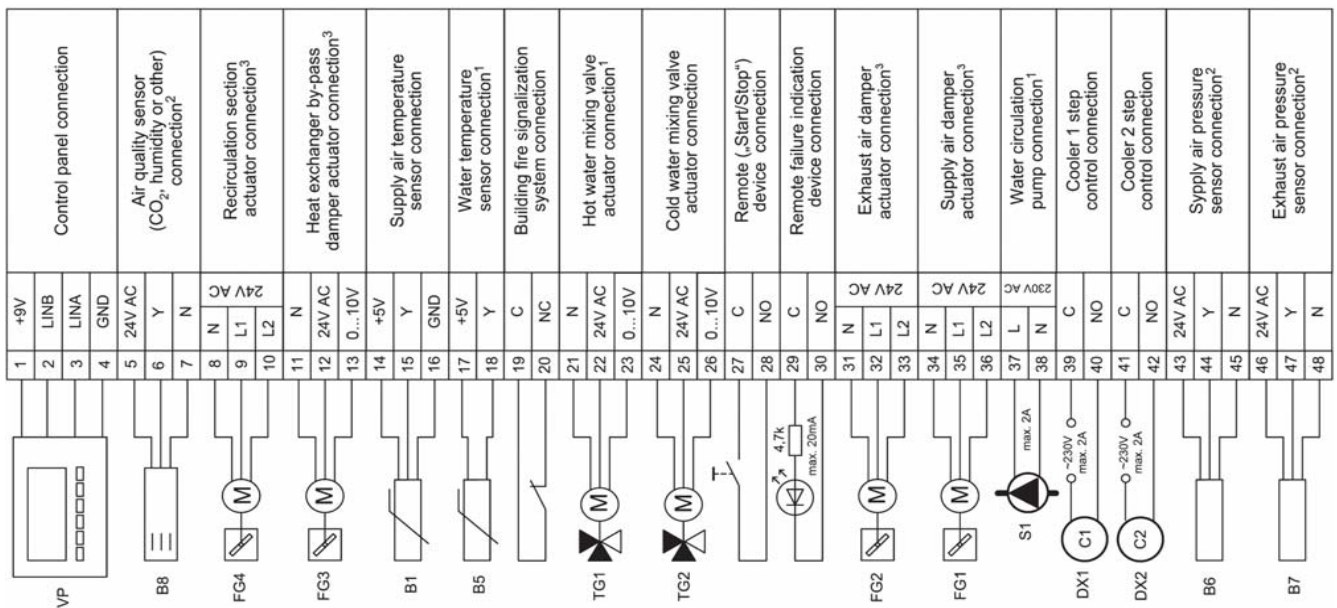

<sup>1</sup> used only in the units with water heater.  
<sup>2</sup> additional ordered function.  
<sup>3</sup> external actuator connection (not used in VERSO units).

## 1.4. Temperature Sensors Installation

Supply air temperature sensor is mounted in the air duct in a projected place for it; after electric heater or cooler section (if provided). The minimal distance from the air vent of the unit up to the sensor should be not less than a diagonal of rectangular connection.

Water temperature sensor is mounted on the return water pipe, as close as possible to the heater case. It is recommended that the sensor would be thermo insulated!



Temperature sensors and control panel connections must be sealed with PVC isolation tape.

## 1.5. Control Panel Installation

1. Control panel must be installed in the room under given following conditions:

1.1. ambient temperature range 0°C ... 40°C;

1.2. relative humidity limits 20% ... 80%;

1.3. protection must be ensured from accidentally vertically falling water drops (IP X2).

2. Installation height must be not less than 0,6 m from the ground.

3. Control panel connection is projected through the hole in its backside.

4. Control panel is fixed after screwing two holes on the fastening surface.

Control panel is connected to the connection box terminals (see 1.3 Picture). The length of the cable between the control panel and the unit should not exceed 150 m. Cable type is specified in unit wiring diagram.

1.5 Picture

### Control Panel Connection

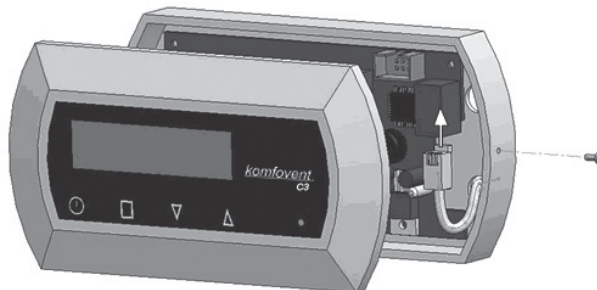

Control panel connection and other cable thicknesses are specified in the wiring diagram!

## 2. OPERATION MANUAL

### 2.1. Unit Control

Air handling units control system ensures control of the physical processes that are taking place inside the air handling unit. Control system consists of:

- controller board;
- fuses, power and intermediate control boards, which are installed inside the unit;
- control panel, which can be installed in the convenient place for the user;
- air damper actuators;
- pressure and temperature sensors.

Control panel (2.1 Picture) is designed for remote air handling unit control, setting and display of controller parameters. Control panel LCD display with backlight allows monitoring various parameters and text messages. Controller light signals indicate unit operation modes and failures. Air temperature, ventilation intensity, operation modes and other parameters are set by the touch sensitive buttons.

2.1 Picture

#### General View of the Control Panel



**Touch sensitive buttons located on the panel mean:**

 start up and shut down of the air handling unit / return to previous menu window;

 entry to parameters change menu / set parameters confirmation;

 navigation in the menu / parameters value change.

### 2.2. Switching on the Unit

After connecting the unit to the electrical power supply, on the control panel LCD displays start-up window, this is shown in the Picture 2.3.

Unit is switched on (off) by touching and holding  button for 4 seconds till sound confirms the action. After switching on, unit will start operating after short delay (about 60 seconds), until air dampers open up, and fans start running. Unit operation is indicated in the control panel by ventilation intensity and LED signals (see further).



Do not switch on the unit without connected earthing! Make sure, whether all unit sections are tightly interconnected.

## 2.3. Control Panel Indication

Data is presented to the user on the control panel LCD display by numbers and text messages, also by two colour LED signals.

Controller display start-up window is shown in the 2.3 Picture.

2.3 Picture

### Control Panel Start-Up Window

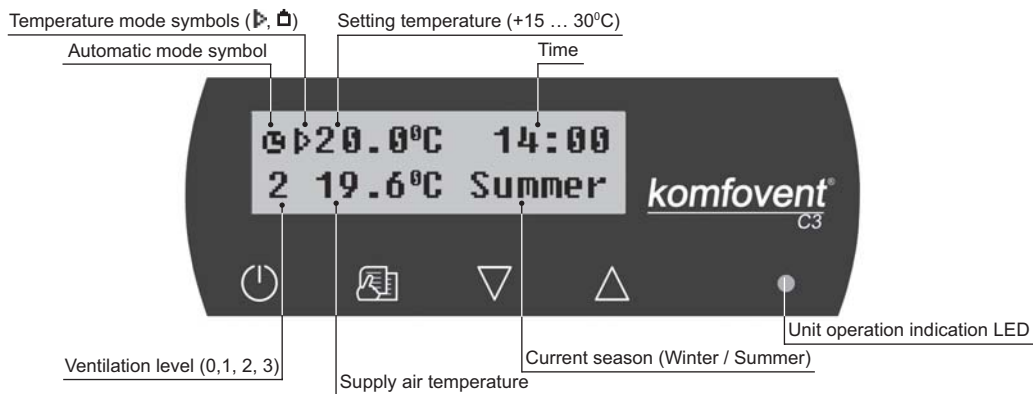



#### Light Diode Indication:

1. No LED signal indication on the panel – **unit has been switched off.**
2. LED shines steady green and text message is shown – **unit is switched on.**
3. Automatic mode symbol is shown on the panel, while green LED shines – **unit is operating in automatic mode according to weekly schedule.**
4. LED blinks red and green and text message is shown – see 2.9 chapter.
5. LED shines steady red and text message is shown – **emergency unit shut down** (see 2.9 chapter).
6. Nothing is showing on the control panel - **unit does not have electric power supply.**

**Note:** By pressing any button on the panel automatically switching on the display backlight. Backlight is off after 30 seconds when no buttons are pressed.

## 2.4. Parameters Review

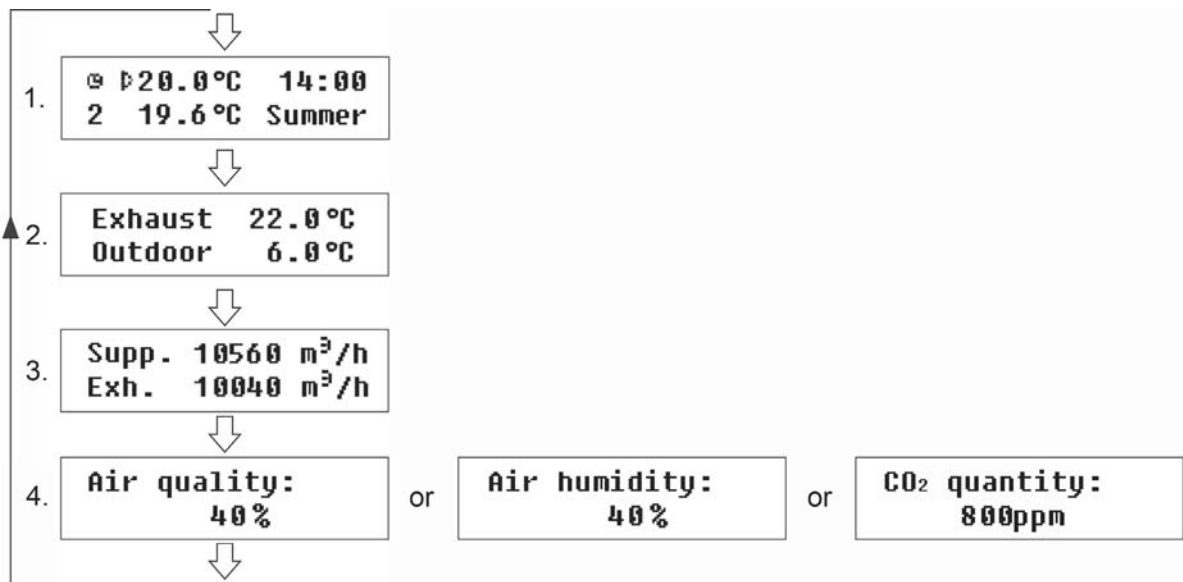

Main parameters are shown in the start-up window (2.3. Picture). To view other parameters (temperature value or air flow indication) touch ,  buttons till corresponding window appears:





 The 3rd and 4th windows are provided only in the units with air flow maintenance function. Depending on the type of mounted air quality sensor, the 4th window may appear in one of three ways. It appears when air quality function is activated (see Air quality function setting).

## 2.5. Quick Ventilation Level Switchover









Three ventilation levels are projected in the unit. Each of them has its intensity (more detailed settings see in the next chapter). There is possibility to switch ventilation level quickly from start-up window (2.3 Picture).

**To increase ventilation intensity:** touch and hold  and at the same moment increase ventilation intensity by touching  button.

**To decrease ventilation intensity:** touch and hold  and at same moment decrease ventilation intensity by touching  button.

 If ventilation intensity is changed using quick switchover and unit is operating according to weekly schedule, operation mode automatically is changed to manual mode.

## 2.6. Unit Programmable Settings

By soft touching  button the parameters menu is entered. Menu window is selected by buttons ,  (see further description). When menu window is selected, touch  for selecting desirable parameters and select the value with , . To confirm the changes touch . To return to previous menu or to start-up window touch  button.

**Note:** If touch sensitive buttons are inactive for 1 minute, start-up window is shown.

### 1. Unit operation modes setting

Two unit operation modes are possible: manual and automatic. In manual mode unit operates continuously by set ventilation intensity. In automatic mode unit works according to weekly schedule (see further weekly schedule setting).



**Note:** If automatic operating mode is selected, there is a symbol  in the start-up window.

### 2. Air volume control setting

Supply and exhaust air volumes control modes have been projected in the unit:



- Constant air volume (CAV) control mode - unit supplies and exhausts constant air volume preset by the user, independent of the processing changes in the ventilation system;
- Variable air volume (VAV) control mode - unit supplies and exhausts air volume correspondingly to the ventilation requirements in different premises. In case of frequently changing ventilation demands this air volumes maintenance mode signally reduces unit exploitation costs.



 Menu window for air volume control setting is provided only in the units having air flow maintenance function.

 If air handling unit is provided with variable air volume control function, primary control mode calibration (look further) is essential, otherwise after choosing VAV mode unit will not operate.

#### Variable air volume control mode calibration:

1. Before activating the device you should adjust air distribution and exhaust devices in ventilation system, open all valves for variable air flow in a way enabling air supply to all ventilated premises.
2. Switch on the unit and by choosing menu window for air volume control setting (see above) actuate constant air volume maintenance mode.
3. After choosing the CAV mode and being at the same menu window touch both  and  buttons at the same moment. After this, calibration will start for 3 minutes and during this time unit will start working on maximum ventilation intensity and there will be displayed „Wait...“ on the control panel. During calibration process all buttons are inactive, except , which allows to shut down the unit and stop the calibration.
4. After finishing the calibration process, air handling unit further will operate in the previously settled mode.

### 3. Setting ventilation level

Three ventilation levels have been projected in the unit: 1, 2 and 3. Each of these levels may be set for manual or automatic operation mode. To set ventilation level in manual mode, select menu window:

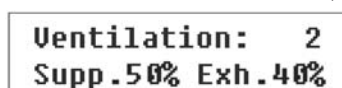

**Note:** In the air handling units provided with **the air flow maintenance function** for each of three ventilation intensity levels maintained air flow can be adjusted and set separately for supply and exhaust air. It can be set from 20 up to 120% by 1% steps. In the unit **without this function** ventilation intensity is only included.

 Air handling unit is designed and calculated to operate on maximum 100% intensity with exceptions when intensity might be set more than 100%.

#### 4. Exhaust air flow correction

Set air flow intensity (or maintained air volume) for 1-99 minutes period can be corrected from -50% till +50% from set value. Example: after reducing exhaust air flow intensity, for some time overpressure will be caused (sometimes needed to start the fireplace or such).

Exh.correction:  
OFF -50% 30min.

“On” - correction function on.

“Off” - function off.

**Note:** After this function has been activated unit will work for the set time period with present exhaust correction. After time period is over this function turns off automatically.



This function is not provided in the units with three speed fan control.

#### 5. Setting temperature maintenance mode

Several temperature maintenance options are provided in the air handling unit: supply air maintenance, room (exhaust) air maintenance, automatic.

T.control: Auto  
→Supply Room





After selecting “Auto”, when cooling is needed, unit will work in the room temperature maintenance mode. If the outside temperature will be few degrees lower than set value, control automatically will switch to supply air maintenance mode.

#### 6. Setting temperature value

Air handling unit maintains preset temperature by the user: supply air or room, depending on which control has been selected (see temperature control mode setting).

Setting temp.:  
▷ 20.0°C

**Note:** If before that supply air temperature maintenance mode was set, in the start-up and temperature value setting window symbol  is indicated; if room temperature maintenance - .

#### 7. Setpoint sliding

The setpoint can be shifted from -9 to +9°C from the temperature set value at specified by user time period. To set setpoint sliding select menu window:

Setpoint sliding  
0°C 00:00 00:00

#### 8. Exhaust air recirculation

Air handling unit with recirculation section has air recirculation function, that is, when for a specified time period all exhaust air flow is returned back to the room.

Recirculation:  
OFF 00:00 00:00

“On” - recirculation function on.

“Off” - function off.



This function is provided only for units with recirculation section; otherwise this menu window is not available on the control panel.

### 9. Air quality function setting

To set the air quality (AQ) function select menu window:

```

"AQ" function:
On VOC1 40%
```

“On” - AQ function on.

“Off” - function off.

After function is activated, the type of sensor, which is connected to the unit, is selected:

“VOC1” (Volatile Organic Compound) – air quality sensor having signal-dependent linear relationship, the maximum value of output signal corresponds to the highest air quality.

“VOC2” – air quality sensor having inverse relationship, the maximum value of output signal corresponds to lowest air quality.

RH – relative humidity sensor.

CO<sub>2</sub> - carbon dioxide sensor.

Depending on the sensor type, the value of AQ function is set, according to it the intensity of the unit is regulated. If actual air quality value varies from the setpoint then ventilation intensity will increase otherwise – decrease.

For instance, if the humidity maintaining system is designed in the device, and there is additional relative humidity (RH) sensor, then by setting 65% in the air quality window, and by regulating the intensity of ventilation automatically, humidity of 65% will be maintained, i.e. if humidity increases, ventilation intensity will be increased as well, and if humidity reduces, the device will switch back to the previous mode.

```

"AQ" function:
On RH 65%
```

This function is not provided in the units with three speed fan control.

### 10. Season setting

For the air handling unit operating in most economical mode, summer and winter seasons have been provided.

- By setting “Winter” season, unit cooling function is blocked.
- By setting “Summer” season, unit heating function is blocked.
- By setting “Auto”, automatic season selection will take place. Depending on the heating and cooling demand, the season is selected automatically.

To set season select menu window:

```

Season:      Auto
→Summer  Winter
```

**Note:** If air temperature during summer season is insufficient, air handling unit can be preset and for “Winter” season mode, its energy expenditures will be minimal.

### 11. Day and time setting

For the unit proper operation in automatic mode according to preset weekly schedule the day of the week and time should be set:

```

Day / Time
Mo  00:00
```

Days notation:

Mo – Monday

Tu –Tuesday

We – Wednesday

Th – Thursday

Fr – Friday

Sa – Saturday

Su – Sunday

### 12. Weekly schedule setting

Two ways for weekly schedule setting have been projected:

- “1-5/6,7” - simplified schedule setting option: one schedule for all work days and the other for weekend operation;
- “1-7” - weekly schedule setting option: different operation schedule for each day.

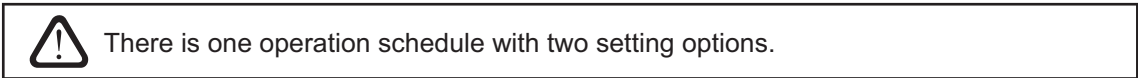

After selecting program for each day of the week “1-7” schedule setting window is introduced:



Each day of the week has 3 events: N1, N2, N3. Settings start from Monday (Mo). When the event of the day is selected, event start and end time is set and ventilation intensity level (0, 1, 2, 3) is assigned.

Before selecting work days and weekend operation mode schedule “1-5/6,7” menu window is introduced:



After event (N1, N2, N3) is selected for work days “1-5”, each event start and end time and ventilation intensity is set the same way. The same way three unit operating events are set for the weekend:

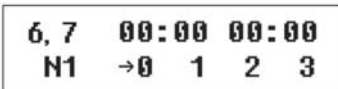

**Note:** Every event start and end time is set from 0:00 to 23:59 h.

**For instance:**

Monday:

- N1 from 00:00 to 07:00 2 ventilation level
- N2 from 10:00 to 20:00 1 ventilation level
- N3 from 20:00 to 23:59 3 ventilation level

### 13. Language setting

Language selection menu has been projected on the control panel. To set language the last menu window should be selected:



### 14. Menu locking



The PIN code is provided to lock entering to the parameters setting menu. If the menu is locked, only main parameters can be reviewed also the unit may be switched on or off.

To enter the PIN code, touch + and hold for 4 seconds till corresponding window appears:



To enter the PIN code follow these steps:

1. Touch or to enter the first digit.
2. Touch to go to the second digit.
3. Repeat the steps above to enter the second and the third digits.

4. After third digit is entered touch  to confirm the code.
5. Touch  and  and hold for 4 seconds to save the code into controller memory.



The menu can be unlocked only with the PIN code. If the code is forgotten, contact local service team.

## 2.7. Other Control Functions

### 1. Remote unit control

Unit is provided with remote control possibility using external device (button, timer, other sensor), which is connected to the contacts 27, 28 (see chapter 1.3) of the connection board.

This function can perform one of two operations:

- remote unit switching on and off;
- remote unit intensity control (additional ordered function).

#### 1.1. Remote unit switching on or off

If the unit is not operating according to programmed week schedule, by connecting (short-circuit) contacts unit will be switched on and will operate with the intensity set in the menu window „Ventilation“ (see page 9); by disconnecting contacts unit operation will return to previous mode.

If unit is operating in auto mode with chosen intensity, to switch it off by remote switch contacts 27, 28 must be connected (short-circuit).



Remote unit switching on and off is available only when auto mode is set!

#### 1.2. Remote unit intensity control

If this function is ordered in advance, unit intensity will be controlled by contacts mentioned above.

If contacts 27, 28 are interconnected, the fourth level of intensity will be activated, after disconnecting – unit will return to previous mode. Adjusting intensity of the fourth level for supply and exhaust fans is performed in the „Ventilation“ window, only when this function is activated, i.e. when these contacts are short-circuited.



Remote unit intensity control has the highest priority and operates in every mode, even the unit is switched off.

**Note:** This function is not provided in the units with three speed fan control.

### 2. Ventilation correction in the winter

In wintertime, when heating power is not enough and supply air temperature is below setting value, ventilation intensity automatically is decreasing in one level. If there is not enough, one more level (up to minimum) till set supply air temperature will be maintained.

### 3. Pump control

Units with water heater are designed with water circulation pump control. In winter pump operates continually, in summer season it is off. When outdoor temperature is lower than 5°C, pump is automatically turned on. Pump is connected to the connection box contacts (see 1.3. chapter).

### 4. Cooling energy recovery

In summer when room temperature is lower than temperature outside, units with either plate heat exchanger or rotary heat exchanger automatically operate with activated function of cooling energy recovery.

### 5. Remote unit operation and failure indication

If the information about unit operation mode is requested (when unit is operating and when is not) indication device (for ex. bulb) must be connected to the contacts 31 and 33 or 34 and 36 of connection board. In the connection box (see chapter 1.3.) are provided 29, 30 contacts, which are intended for connection of unit's emergency stop indicating device.

## 2.8. Unit PC control

This is additionally ordered function and for its implementation special network module is provided. It allows monitoring and controlling unit operation, through computer network or Internet. Connection diagram is given in the 2.8 Picture.

2.8 Picture

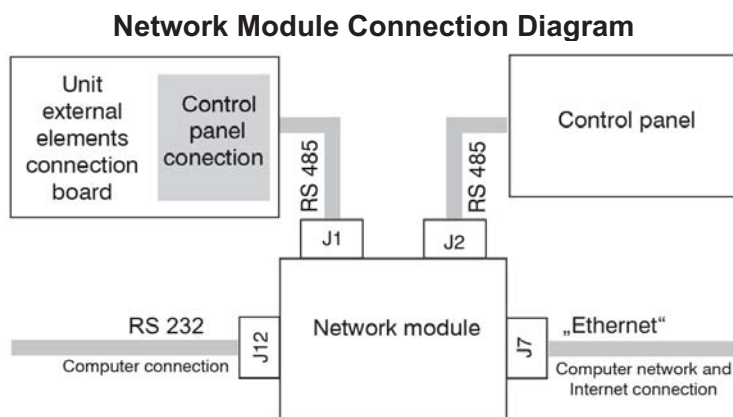

After connecting units through special network modules to computer network or Internet and given an IP address, *Ventilation Control System* visualization program allows the operator from his computer not only to monitor, but also to control air handling units operation: to turn on/off, change ventilation intensity and etc. It also allows indicating failures. Detailed unit computer control description is given in the computer program using instruction.

## 2.9. Troubleshooting

If the unit is not working:

- Make sure if the unit is connected to the electrical power supply.
- Check if the unit main switch is on, it is located on the unit wall (if designed).
- Check all control block fuses. If needed, change failed fuses with the new ones that are the same electrical parameters as old ones (fuses types are shown in wiring diagrams).
- Check if there is not failure indication on the control panel. If there is indication, it needs to be eliminated first. To eliminate failure use 2.9 Table, which describes failures.
- If nothing is indicating on control panel, check whether cable connecting control panel with the unit is not damaged.

2.9 Table

**Failures indicated on the control panel, possible reasons and its elimination**

Message	LED	Possible Failure Cause	Failure Elimination
Change supply air filter	Red and green blinking	Supply air filter is clogged.	After unit is off, it is necessary to change filter.
Change exhaust air filter	Red and green blinking	Exhaust air filter is clogged.	After unit is off, it is necessary to change filter.
Low supply air temperature	Red light	Supply air temperature dropped lower allowable level.	Check program settings, unit heat exchanger and heater operation.
Supply air overheating	Red light	Supply air temperature is higher allowable level.	Check program settings, unit heat exchanger and heater operation.

Message	LED	Possible Failure Cause	Failure Elimination
Supply air fan overheating	Red light	Supply air fan motor overheated due to excessive load.	Check if air filters are inserted, if the unit doors are closed, if unit ventilation system has been installed correctly.
Exhaust air fan overheating	Red light	Exhaust air fan overheated due to excessive load.	Check if air filters are inserted, if the unit doors are closed, if unit ventilation system has been installed correctly.
Heater off	Red and green blinking	Heater is disconnected due to low air flow.	When heater cools down, protection restores automatically. It is recommended to increase ventilation intensity level.
Electric heater overheating	Red light	Electric heater overheating protection is on.	To restore protection, it is possible only after pressing "RESET" button, which is located on the heater.
Return water low temperature	Red light	Return water temperature in water heater dropped lower allowable level.	Check circulation pump and heating system condition, heating valve actuator performance.
Frost possibility	Red light	Temperature of the air passing through plate heat exchanger, dropped lower allowable level.	Check by-pass damper condition and actuator performance. It is recommended to decrease ventilation level.
Rotor stopping	Red light	The belt is broken, or failure of the rotor motor.	Check rotor drive and rotation sensor condition.
Fire alarm	Red light	Received fire alarm signal from the building fire system.	When fire alarm signal disappears, unit needs to be restarted from control panel.
B1 sensor failure	Red light	Supply air temperature sensor is not connected or broken down.	It is necessary to check sensor connections or change the sensor.
B2 sensor failure	Red light	Exhaust air temperature sensor is not connected or broken down.	It is necessary to check sensor connections or change the sensor.
B3 sensor failure	Red light	Outdoor temperature sensor is not connected or broken down.	It is necessary to check sensor connections or change the sensor.
B4 sensor failure	Red light	Plate heat exchanger temperature sensor is not connected or broken down.	It is necessary to check sensor connections or change the sensor.



It is possible to restore emergency overheating protection with button "RESET", only if before heater overheating cause has been clarified and eliminated.



If the unit has been stopped and there is red light diode signal on the controller, and text message is shown meaning failure, failure needs to be eliminated!



Before performing any jobs inside the unit make sure that the unit is stopped and disconnected from the electrical power supply.

After failure has been eliminated and power supply connected, text message appears about previous failure. If there are no more failures, unit is switched on by pressing  button; unit continues operating by preset mode. However if the failure has not been eliminated, unit either starts operating and after some time it stops again, or it does not operate and failure message is indicated.

## VERSO-P - Air Handling Units Functional Diagram

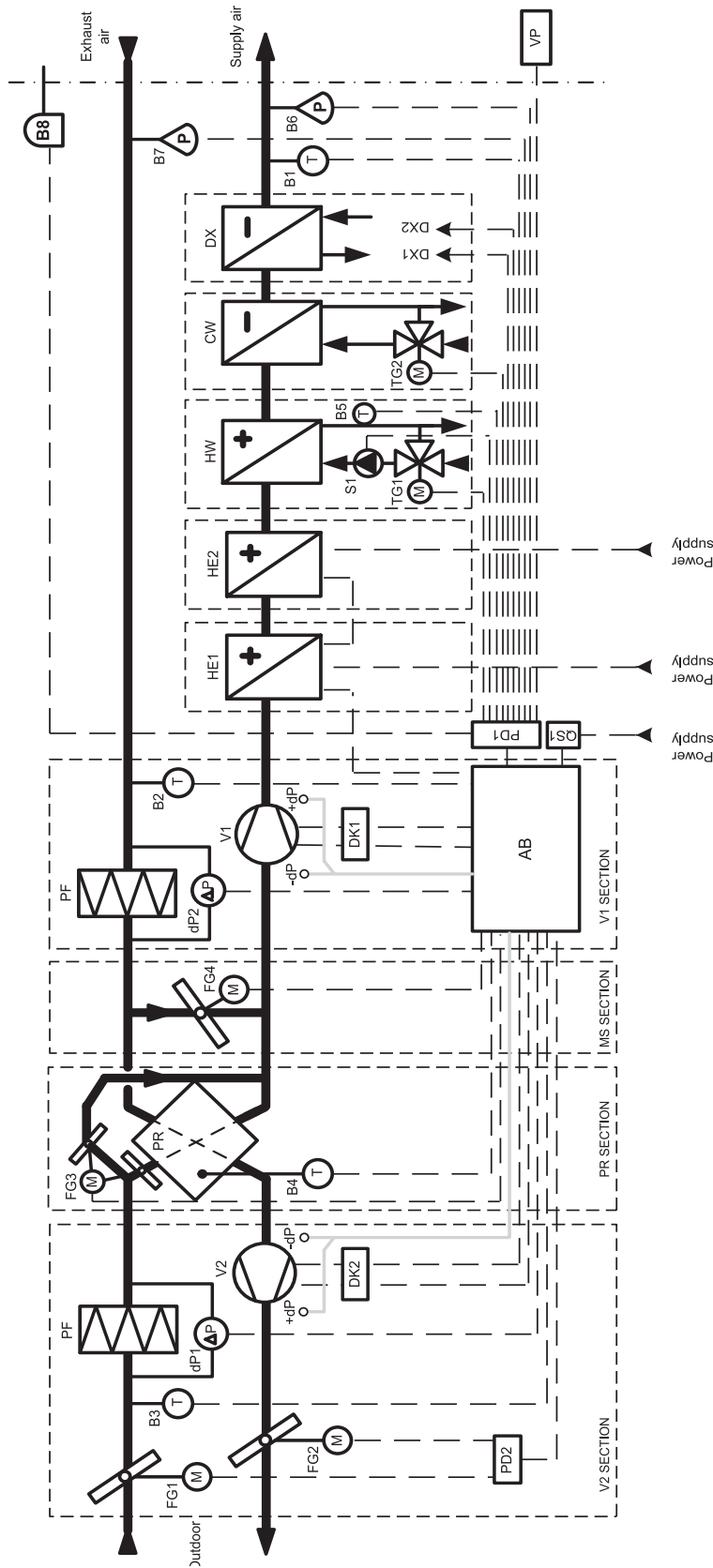

AB	Control box	DX cooling control	Air filter
B1	Supply air temperature sensor	Pressure switch for filter	Plate heat exchanger
B2	Exhaust air temperature sensor	Supply air damper actuator	Connection box
B3	Outdoor temperature sensor	Exhaust air damper actuator	Main switch
B4	Heat exchanger temperature sensor	By-pass damper actuator	Circulation pump
B5	Return water temperature sensor	Air recirculation damper actuator	Hot water mixing valve actuator
B6, B7	External pressure sensor	Electric heater	Cold water mixing valve actuator
B8	Air quality sensor	Additional electric heater	Supply air fan
CW	Water cooler	Water heater	Exhaust air fan
DK1, DK2	Frequency inverter	Air recirculation section	Control panel
DX1, DX2			
dP1, dP2			
FG1			
FG2			
FG3			
FG4			
HE1			
HE2			
HW			
MS			
PD1, PD2			
QS1			
S1			
TG1			
TG2			
V1			
V2			
VP			



Depending on the type of the unit, there are possible different control system principal solution. Maximal option is given in the wiring diagram. By considering below given charts specific unit composing parts specifications are selected.

	With electric heater	With water heater
VERSO-P	A + C + D	A + C
VERSO-R	A + B + D	A + B

**Notes:**

*If computer control function is provided, additional board M1 is used.*

*If electric heater is more powerful than 45kW, two heaters EH1 and EH2 are used.*

*If the unit has recirculation section, recirculation valve actuator FG4 is used.*

### Specification of the Components

Mark	Marking	Name
A	C3	Controller
	D3S	Commutation board
	C3-P1	External connections board
	DK1	Supply air fan frequency inverter
	DK2	Exhaust air fan frequency inverter
	F1	Fuse
	FG1	Supply air damper actuator
	FG2	Exhaust air damper actuator
	B2	Exhaust air temperature sensor
	B3	Outdoor temperature sensor
	dP1	Supply air filter dif. pressure switch
	dP2	Exhaust air filter dif. pressure switch
	QF1-3	Circuit breaker
	QS1	Main switch
TF1,TF2	Mains filter	
B	D1	Rotor rotation sensor
	DK3	Rotary heat exchanger frequency inverter
C	B4	Plate heat exchanger temperature sensor
	FG3	Plate heat exchanger By-pass damper actuator
	C3-X1	Electric heater connection board
	E	Electric heater power control board
D	EK1...EK3	Electric heater stages
	KM1..KM3	Electric heater stages protection contactors
	S1...S6	Triac
	TK1	Electric heater 80°C overheating protection (automatic reset)
	TK2	Electric heater 120°C overheating protection (manual reset)
	TK3	Triac 70°C overheating protection (automatic reset)
	QF1-3	Circuit breaker
QS1	Electric heater main switch	
	<b>Other markings:</b>	
	PD1...PD4	Connection boxes
	X1...X14	Connections between unit sections





**UAB AMALVA**

Ozo str. 10,  
LT-08200 VILNIUS, LITHUANIA  
e-mail [info@amalva.lt](mailto:info@amalva.lt)  
[www.amalva.com](http://www.amalva.com)  
[www.komfovent.com](http://www.komfovent.com)