

Instruction Manual for **VERSO-S, VERSO-P, VERSO-R**

Safety Instructions



Do not switch on an ungrounded air handling unit.



Before switching on the unit, all doors must be closed and locked; the safety covers should be bolted.



Before switching on the unit, its compartments have to be fixed fast among them.



There is pressure inside the air handling units; this is why it is forbidden to open any doors before switching off the unit.



Before performing any inspection work inside the unit, be sure the unit's electric power supply is disconnected and there are no rotating parts.



Before opening the doors, switch off the unit and its main switch and wait for 1-2 minutes till the fans will stop rotating.



Before switching on the air handling unit, activate all the safety functions.



The air handling unit can be switched on or off only by the means specified in the control system.



Be careful when doing water air heater assemblage works - heat exchanger can get as hot as 130°C!



Warning:

If the air handling unit does not have the manufacturer's control system, then the company that installed automation is responsible for the unit's functioning and safety reliability.

Table of Contents



VERSO air handling units	4
Sizes	5
Specifications	6
VERSO-S – air supply units	7
VERSO-P – air handling units equipped with plate heat exchanger	8
VERSO-R – air handling units equipped with rotary heat exchanger	9
Composing options	10
Design	11
Fans	11
Plate heat exchangers in VERSO-P air handling units	12
Rotary heat exchangers in VERSO-R air handling units	14
Air dampers	15
Electrical damper actuators installation. Electrical drives safety	16
Air filters and filter change procedures	17
Water air heaters, air coolers, direct evaporation air coolers	18
Electric air heaters	23
VERSO outdoor version accessories	28
Transportation	29
Service space	30
Unit installation and mounting	31
Electric connection	32
Air ducts connection	35
Condensate draining	36
Units marking	37
Testing and switching on the unit	39
Noise level	40
Warranty conditions	41

VERSO Air Handling Units

UAB „Amalva“ thanks you for choosing VERSO air handling unit. Because a lot of attention is given towards unit quality we will be thankful for your help expressing your comments and responses, or suggestions regarding technical and running qualities of the unit.

To avoid misunderstandings, before installing the unit, carefully read this instruction. Keep the instruction, warranty and technical information data – you may need them during exploitation.



Inspect the air handling unit carefully to make sure it was not damaged during transportation.



More detailed information about the parameters of the VERSO air handling units can be found in the AHU's printout (technical specifications).

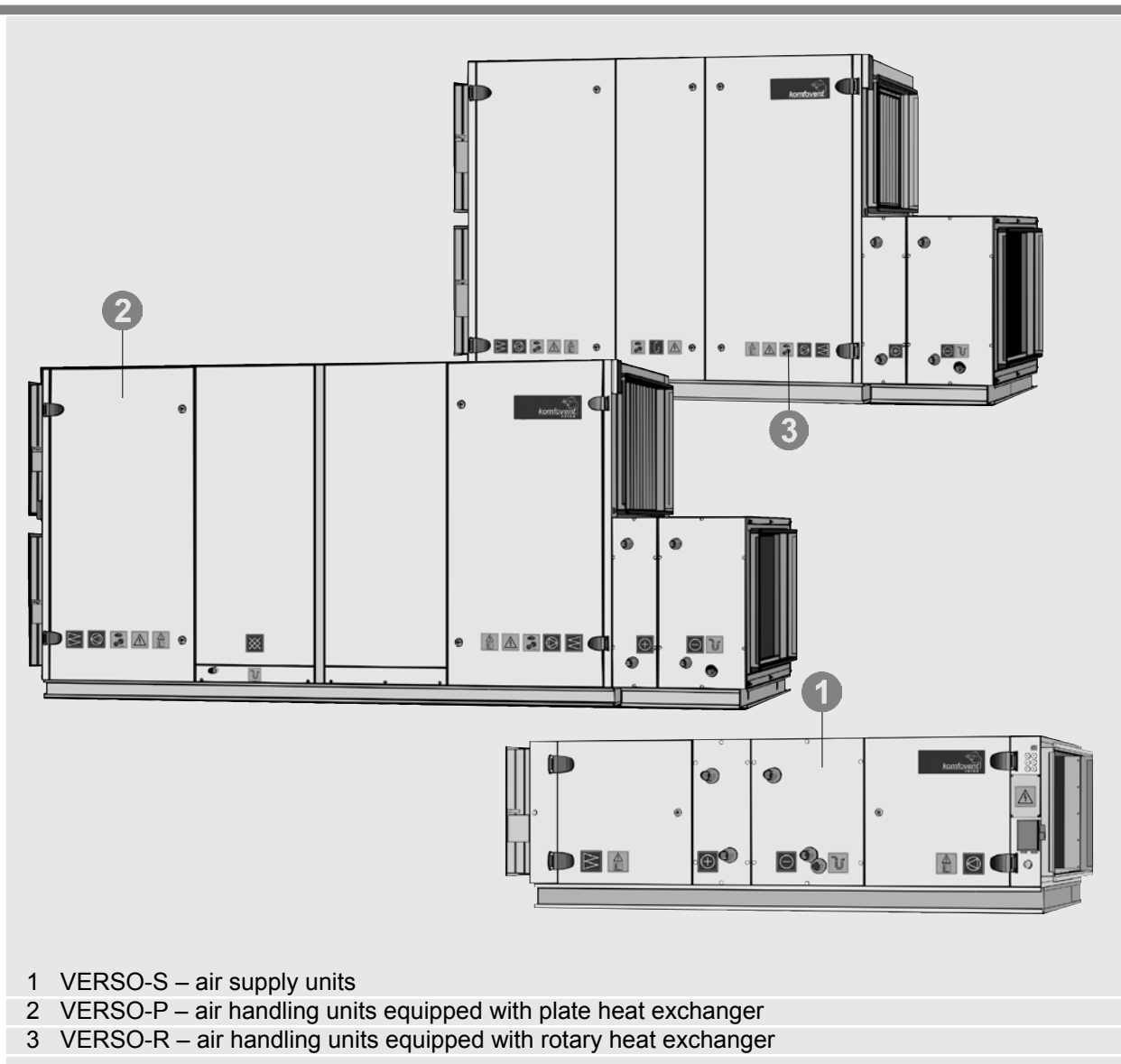

VERSO Air Handling Units Sizes

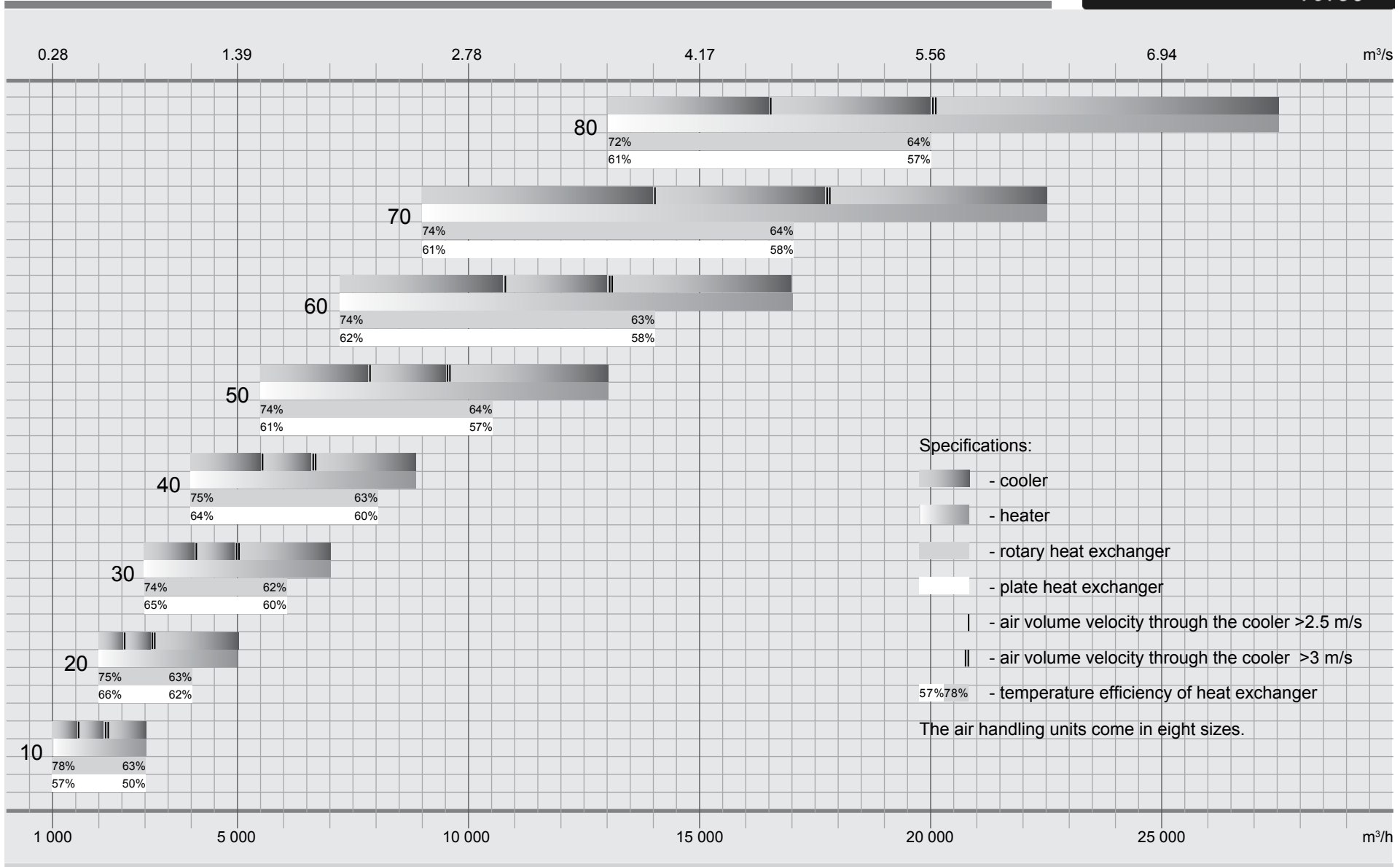

VERSO Air Handling Units' Specifications

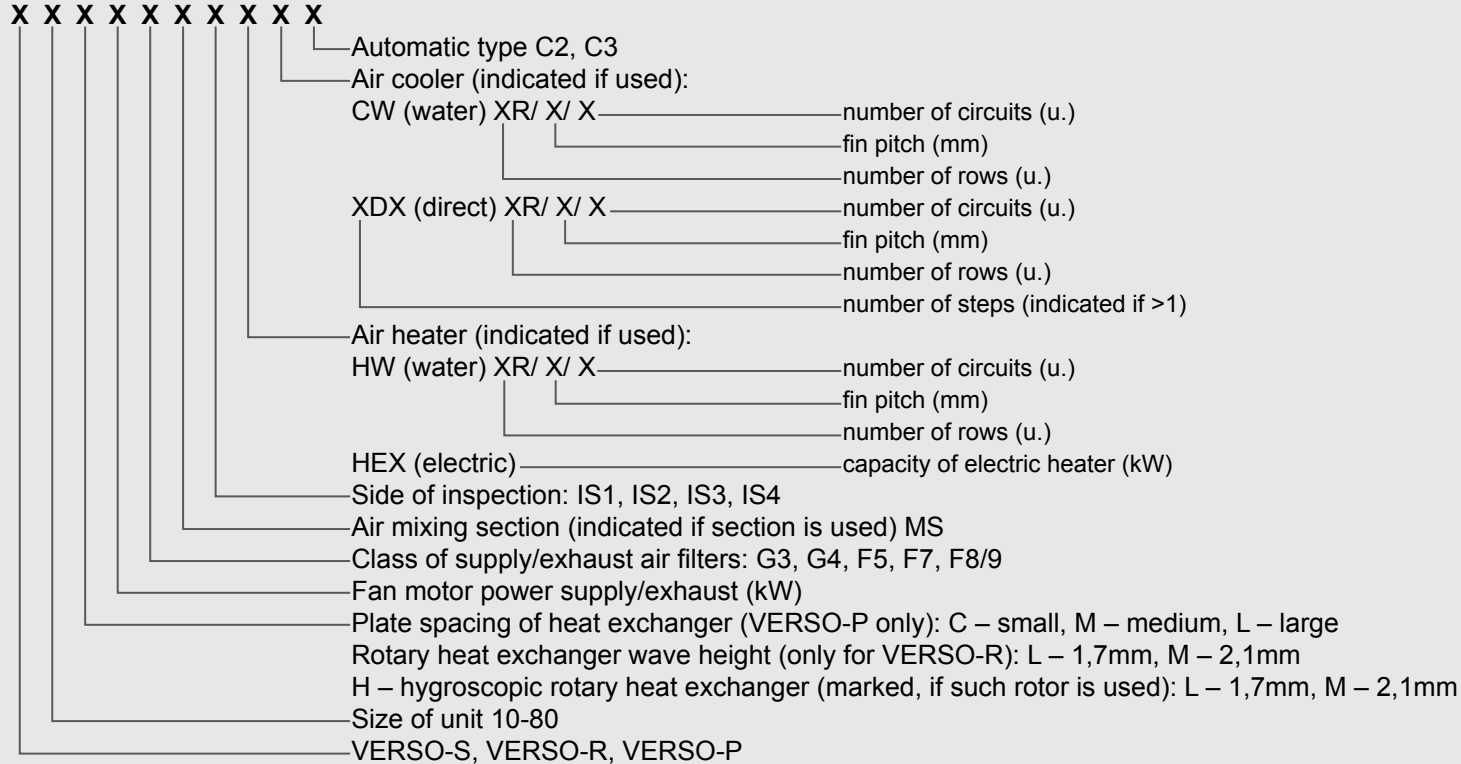

Example: **VERSO-S-30-1,5-F5-IS2-HW3R/3,0/3-CW/2R/2,5/2-C2**
VERSO-P-30-L-2,2/2,2-F5/G3-X-IS4-HW2R/3,0/2-CW/2R/2,5/2-C3
VERSO-R-30-MH-2,2/2,2-F7/F7-MS-IS1-HE15-DX/1R/2,5/4-C3

VERSO-S – Air Supply Units

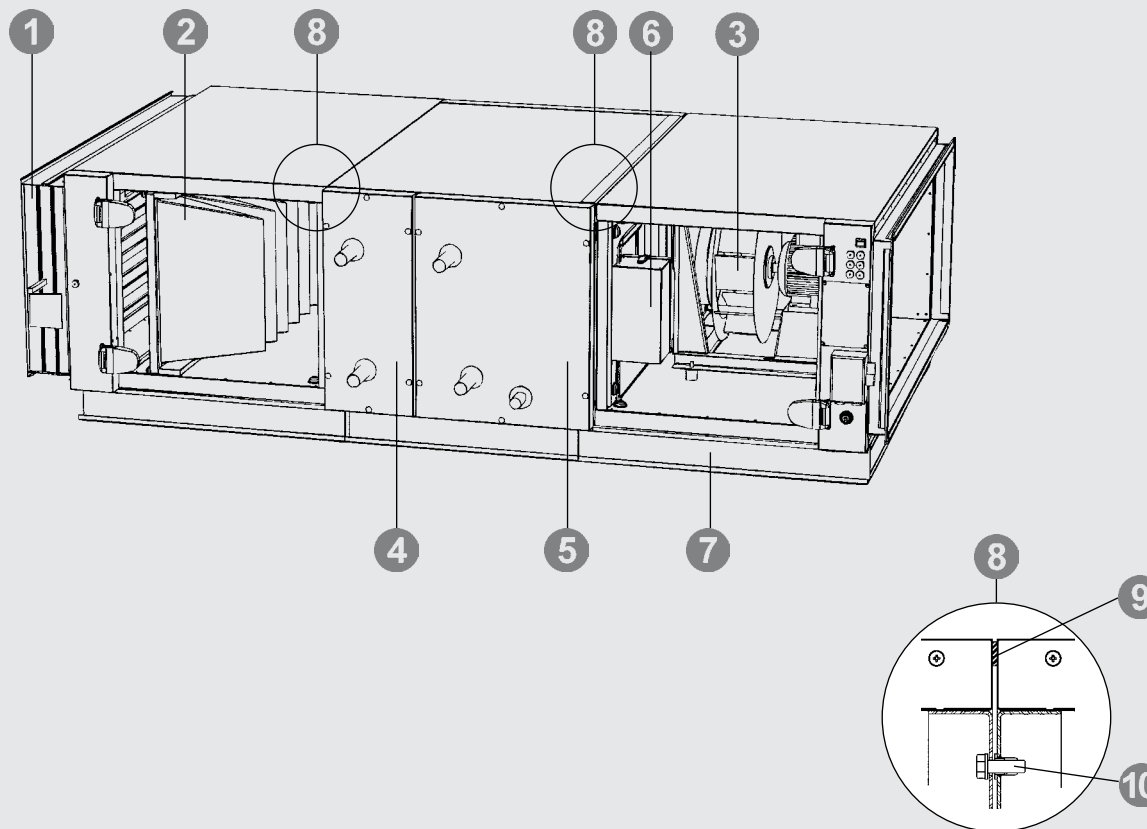

- 1 Air damper (closing)
- 2 Supply air filters
- 3 Fan with electric motor
- 4 Air heater (water or electric)
- 5 Air cooler (water or direct evaporation)
- 6 Frequency inverter
- 7 Base frame
- 8 Sections connection
- 9 Sealing gasket
- 10 Connection bolt

VERSO-P – Air Handling Units Equipped with Plate Heat Exchanger

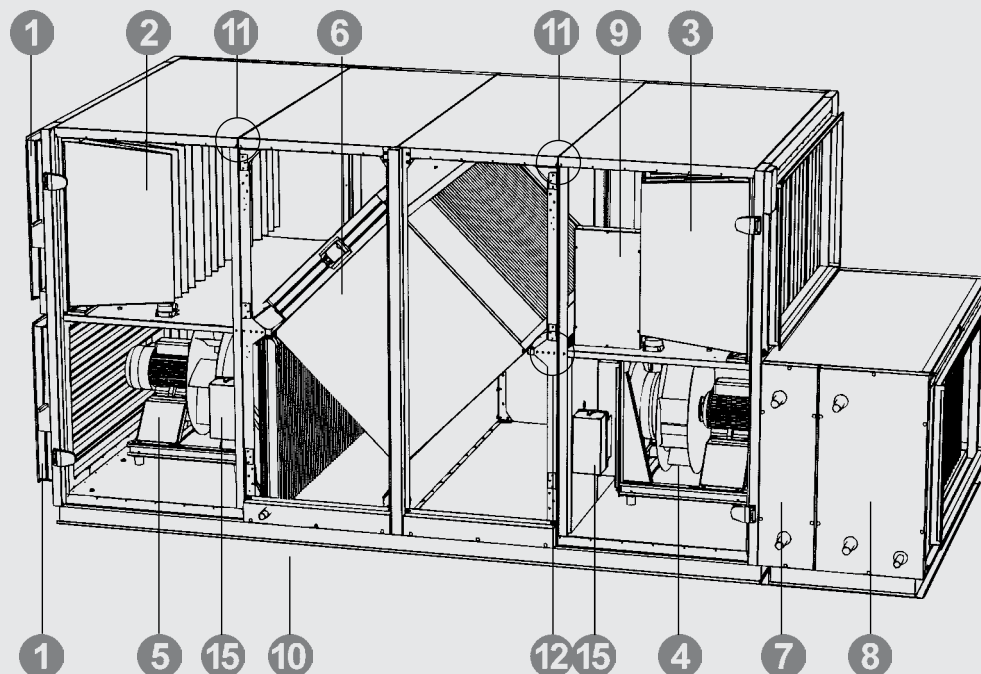

- 1 Air dampers (closing)
- 2 Supply air filters
- 3 Exhaust air filters
- 4 Supply air fan with electric motor
- 5 Exhaust air fan with electric motor
- 6 Plate heat exchanger
- 7 Air heater (water or electric)
- 8 Air cooler (water or direct evaporation)
- 9 Control system
- 10 Base frame
- 11, 12 Sections connection
- 13 Sealing gasket
- 14 Connection bolt
- 15 Frequency inverter

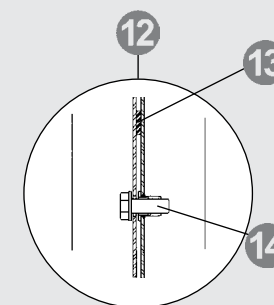
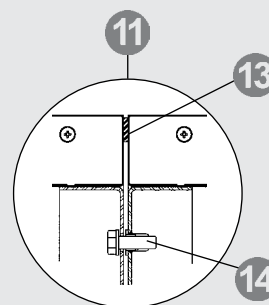

VERSO-R – Air Handling Units Equipped with Rotary Heat Exchanger

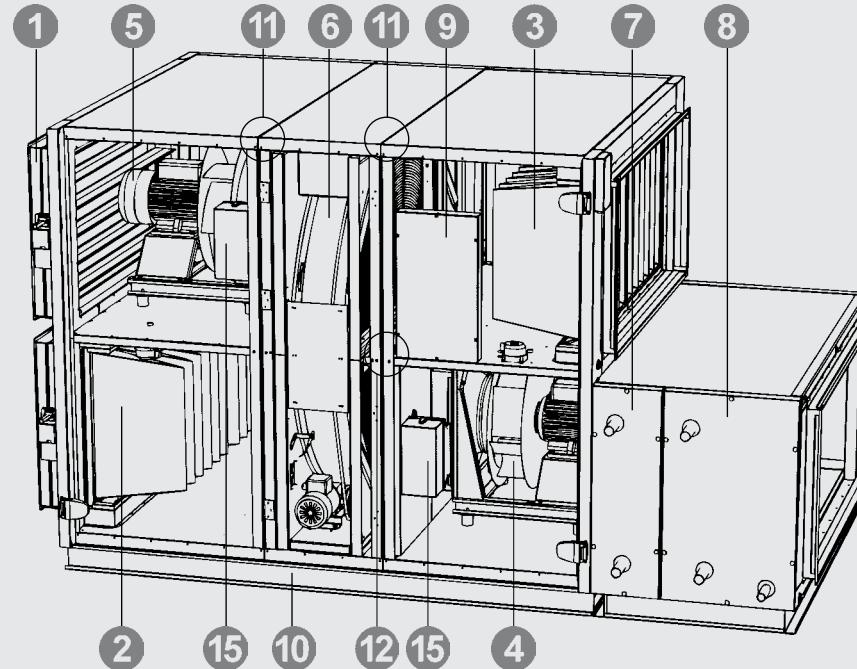

- 1 Air dampers (closing)
- 2 Supply air filters
- 3 Exhaust air filters
- 4 Supply air fan with electric motor
- 5 Exhaust air fan with electric motor
- 6 Rotary heat exchanger
- 7 Air heater (water or electric)
- 8 Air cooler (water or direct evaporation)
- 9 Control system
- 10 Base frame
- 11, 12 Sections connection
- 13 Sealing gasket
- 14 Connection bolt
- 15 Frequency inverter

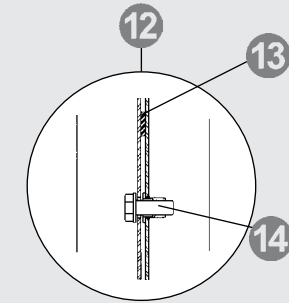
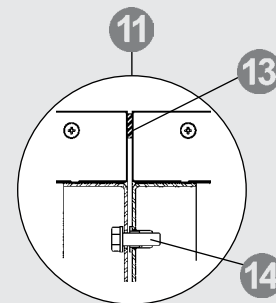

VERSO Air Handling Units Composing Options

IS-1

Air handling unit inspection doors on the right; supplied airflow into room is on the bottom of the unit.

IS-2

Air handling unit inspection doors on the left; supplied airflow into room is on the bottom of the unit.

IS-3

Air handling unit inspection doors on the right; supplied airflow into room is on the top of the unit.

IS-4

Air handling unit inspection doors on the left; supplied airflow into room is on the top of the unit.

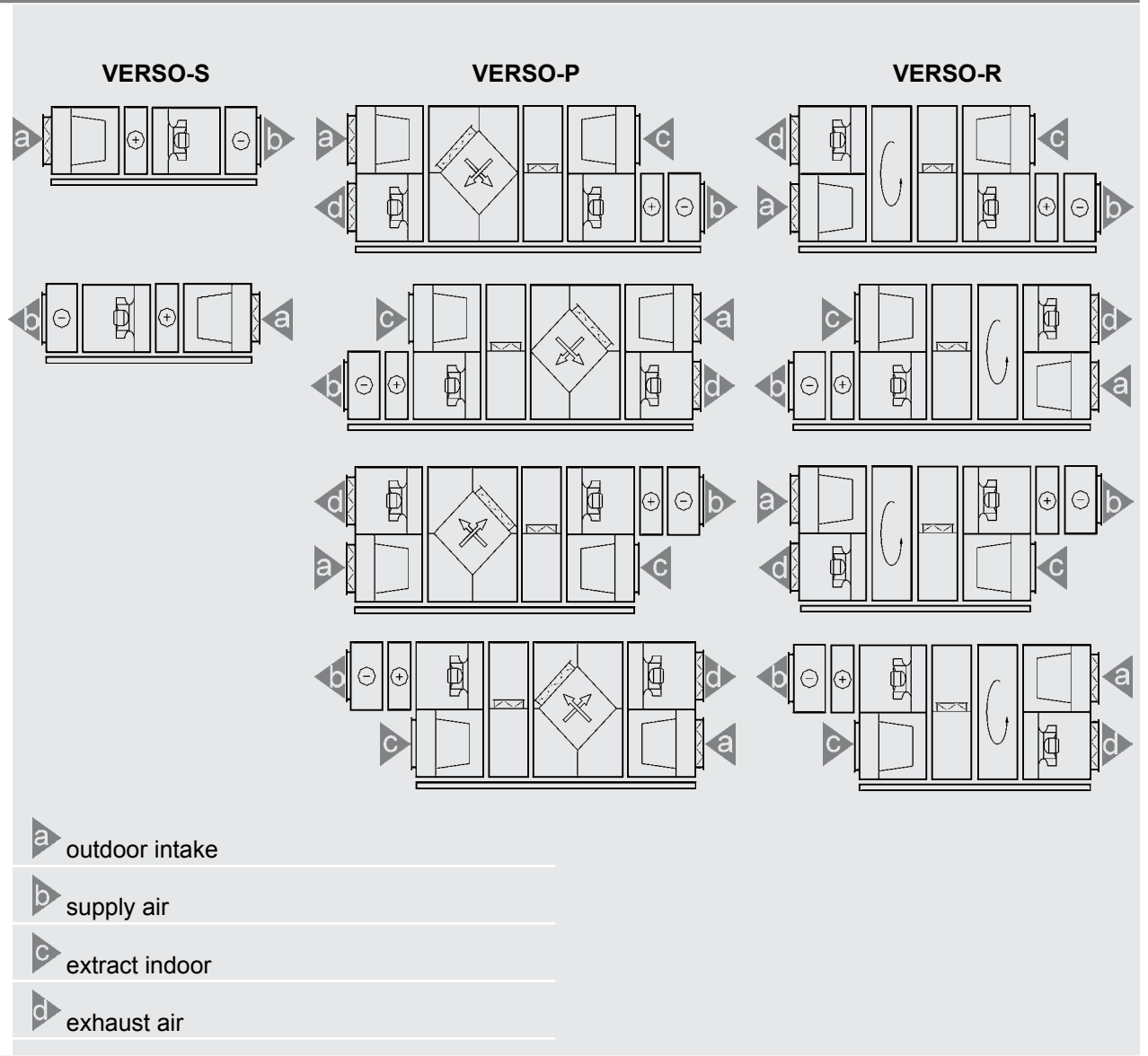

Fans

VERSO air handling units are equipped with radial fans with direct drive.



Motors of the fans with backward curved blades must be controlled by frequency converters. Frequency set by the frequency inverter cannot exceed frequency data specified in the print out.

Note: fan type is specified in the print out.

Measuring device for determining air volume.

The differential pressure compares the static pressure in front of the inlet ring with the static pressure in the inlet ring of the narrowest point.

The differential pressure between the static pressures is related to the air volume via the energy conservation rate as follows:

$$\nabla = k \cdot \sqrt{\Delta p_w}$$

where k takes into account the specific ring characteristics.

Example: If differential pressure of 7000 Pa is measured for size 630, the air flow rate can be calculated:

$$\nabla = k \cdot \sqrt{\Delta p_w} = 381 \cdot \sqrt{700} = 10080 \text{ (m}^3\text{/h)}$$

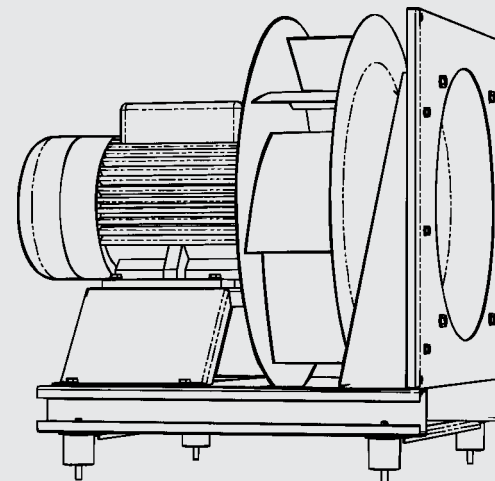

Fan	Coefficient - k
RH22C	47
RH25C	60
RH28C	75
RH31C	95
RH35C	121
RH40C	154
RH45C	197
RH50C	252
RH56C	308
RH63C	381
RH71C	490
RH80C	620

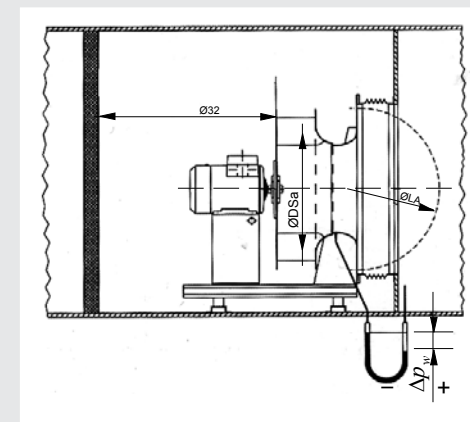

VERSO Air Handling Units Construction

Plate Heat Exchanger in VERSO-P Air Handling Units

When operating the air handling unit equipped with the plate heat exchanger, unit control automation should have function of protection from frost

Condensate can accumulate in a plate heat exchanger; therefore it is essential to install siphons on the condensate drainpipes. Depending on the unit construction, plate heat exchanger section may have 1 or 2 siphones.



It is important to maintain cleanliness of the plate heat exchanger: to change filters installed in the air handling unit on time, if the heat exchanger gets dirty, to perform heat exchanger periodical cleaning. The temperature effectiveness of a dirty heat exchanger can diminish considerably.

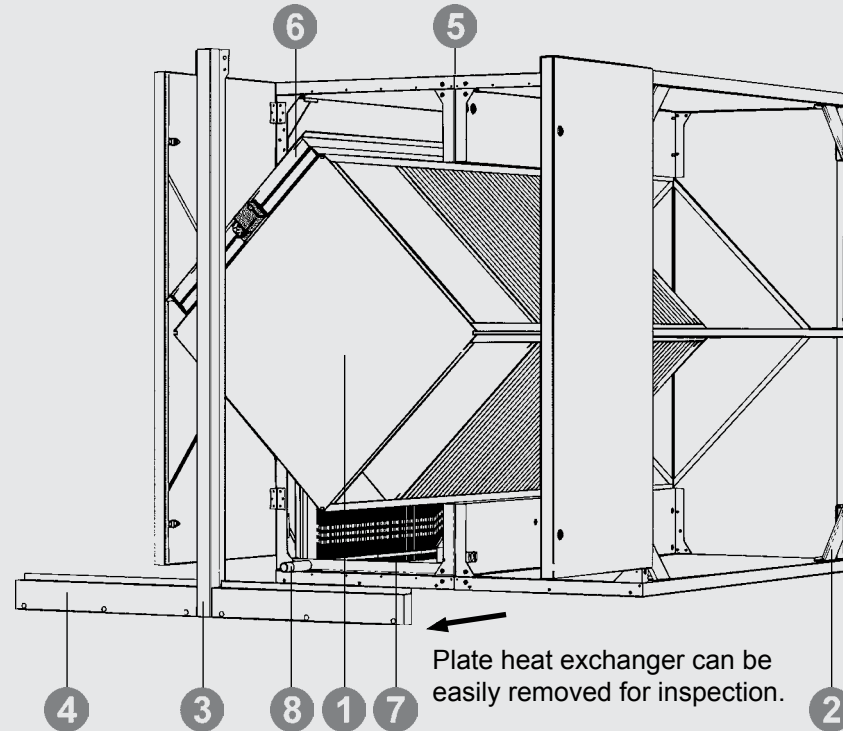

- 1 Plate heat exchanger
- 2 Support frame
- 3 Frame
- 4 Bottom shields
- 5 Place of sections connection
- 6 Bypass damper with actuator
- 7 Drop eliminator (if needed)
- 8 Condensate bath with drainage

VERSO Air Handling Units Construction



Removing plate heat exchanger from
VERSO-P air handling units.
Demounting of the section.

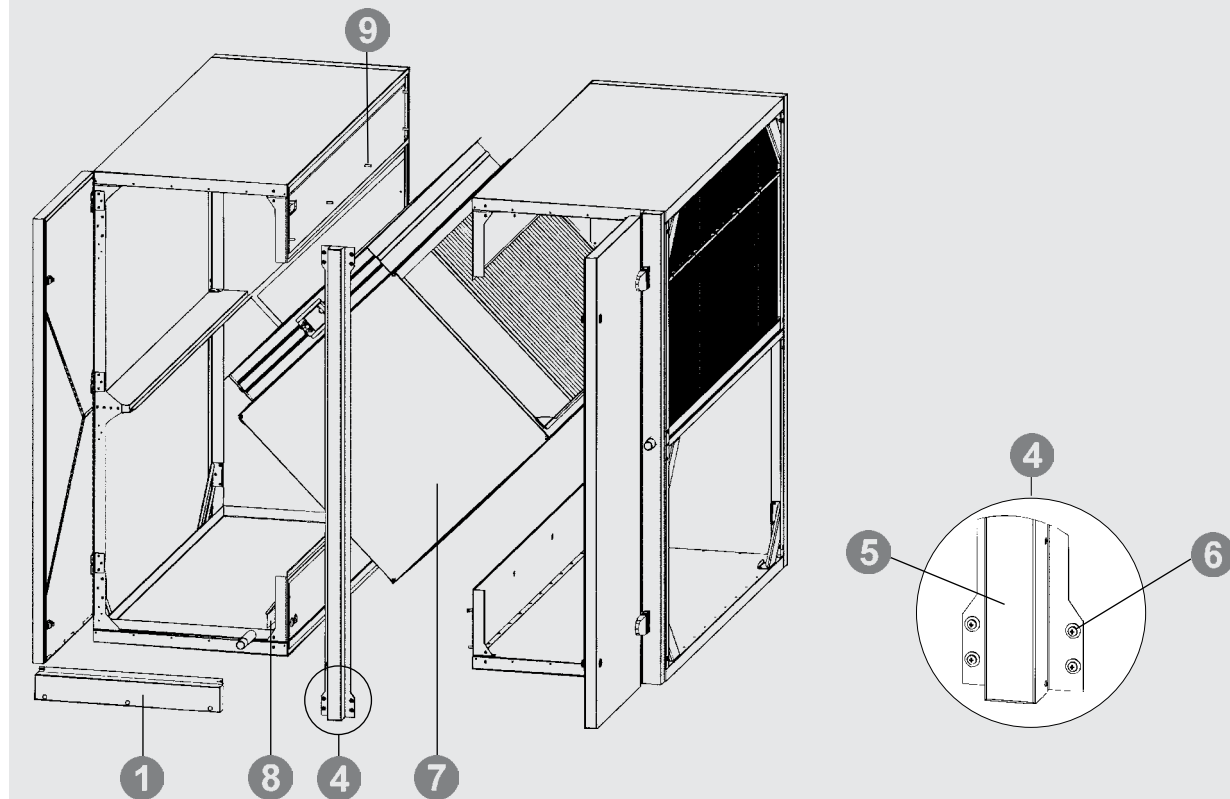

- 1 Screws are unscrew; bottom shields are removed
- 2 Plastic axle-pin
- 3 Screw
- 4 Frame bolts are removed; the frame is removed
- 5 Frame
- 6 Frame bolts
- 7 Plate heat exchanger is removed
- 8 Condensate diversion mechanism is removed
- 9 Bolts connecting the sections are removed



VERSO Air Handling Units Construction

Rotary Heat Exchanger in VERSO-R Air Handling Units

If a regulator is used, it is possible to change the speed of rotation from 0 to 10 RPM (RPM). The heat exchanger actuator mechanism is oiled with synthetic solution; therefore there is no need to oil mechanism during its exploitation.



It is important to make sure that the rotary heat exchanger mechanism is clean: to change the filters installed in the air handling unit on time, to perform periodical heat exchanger cleaning. The temperature efficiency of a dirty heat exchanger can diminish considerably.

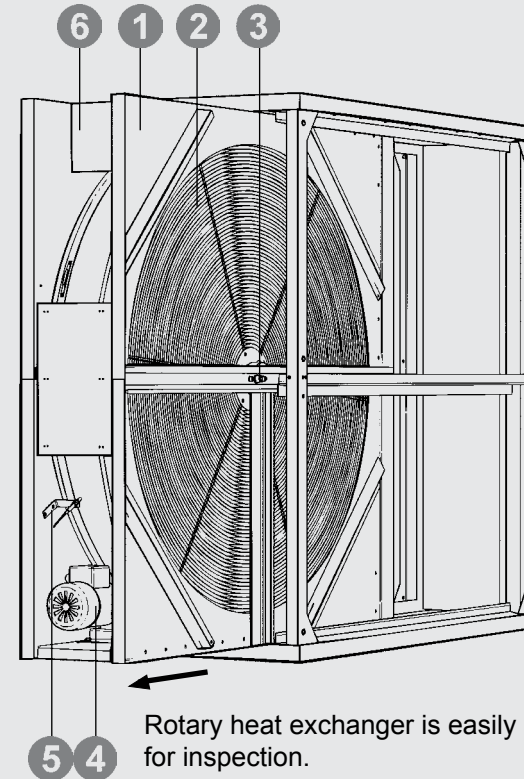

- 1 Rotary heat exchanger frame
- 2 Rotor
- 3 Shaft
- 4 Actuator with a reducer
- 5 Rotary heat exchanger sensor
- 6 Plane for fixing frequency inverter

Air Dampers

Closing air dampers with aluminium or galvanized steel blades are used in the units.

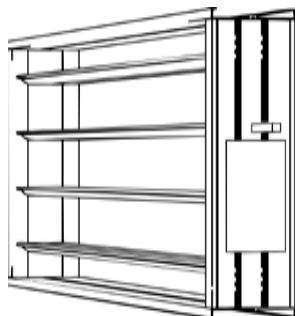

Air damper is fixed to the air handling unit with screws.

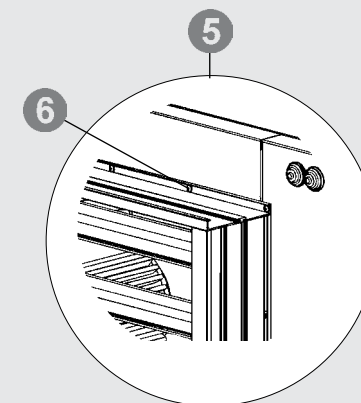
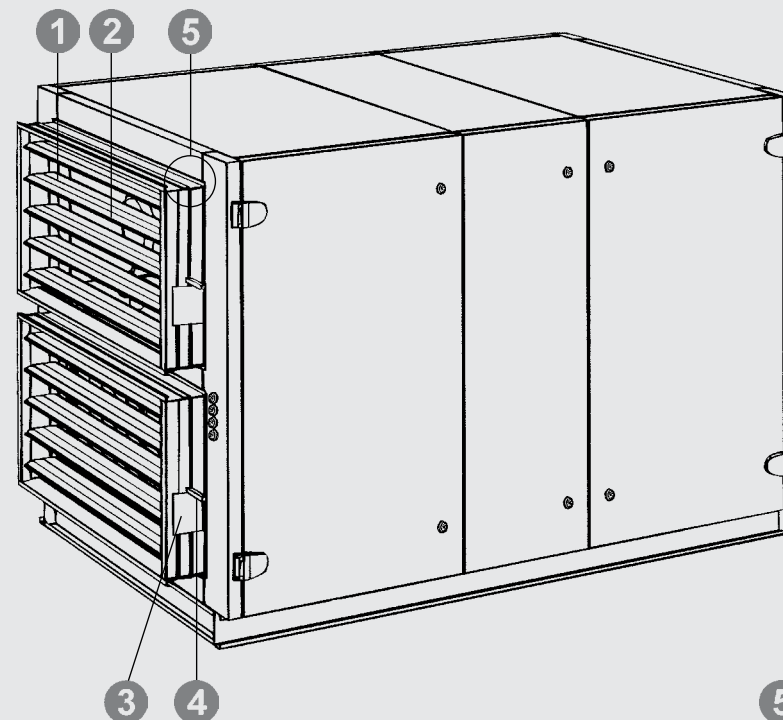

- 1 Aluminum or galvanized steel blades
- 2 Rubber sealing
- 3 Plate shaft for the actuator
- 4 Shaft for bypass damper closing/opening
- 5 Fastening bend
- 6 Screw

VERSO Air Handling Units Construction

Installing Electrical Drives on the Air Dampers.

Electrical Dampers Safety.

The electrical actuators control air dampers of the air handling unit.

If air handling unit is installed outside, then all the drives outside have to be protected from moisture and dust.

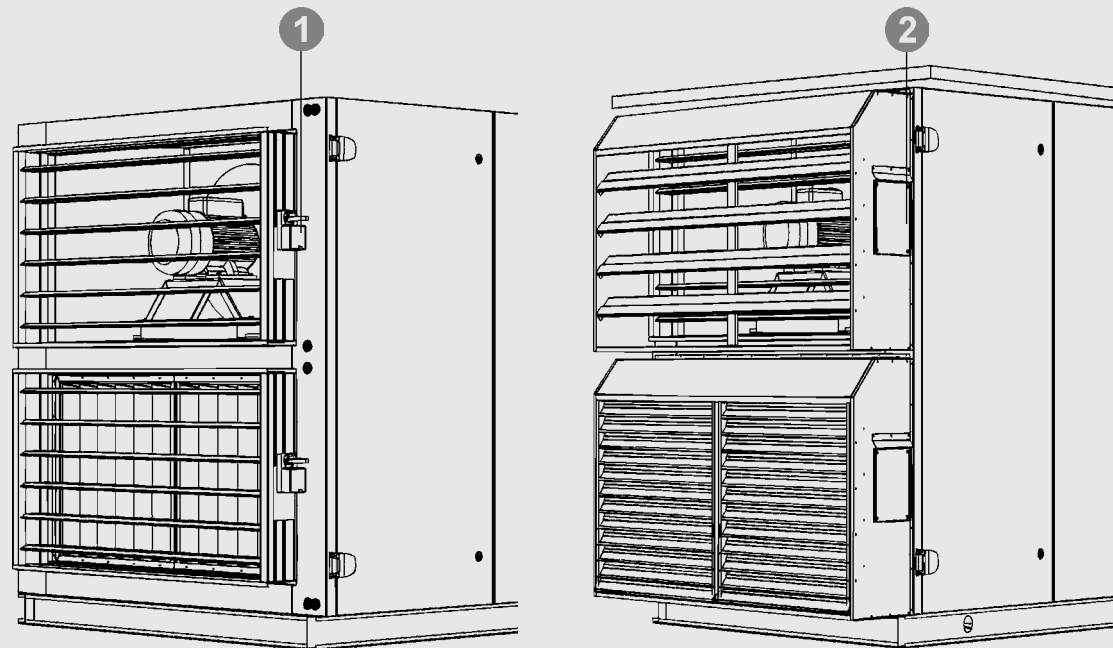
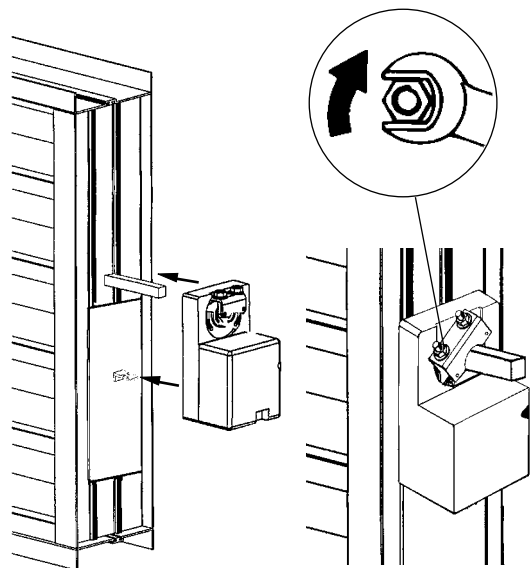

1 Electric drive fixed to the air handling unit installed in a building

2 Electric drive fixed, under the cap, to the air handling unit installed outdoors

Air Filters and Filter Change Procedure

Synthetic or fiberglass bag filters are used.

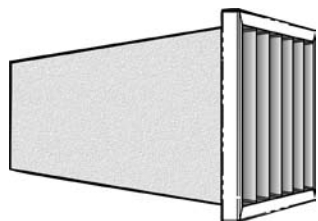

When operating the air handling unit, the unclean filters should be changed on time.

Pressure level drop at which it is recommended to change filters, and the measurements are in the technical data pages.

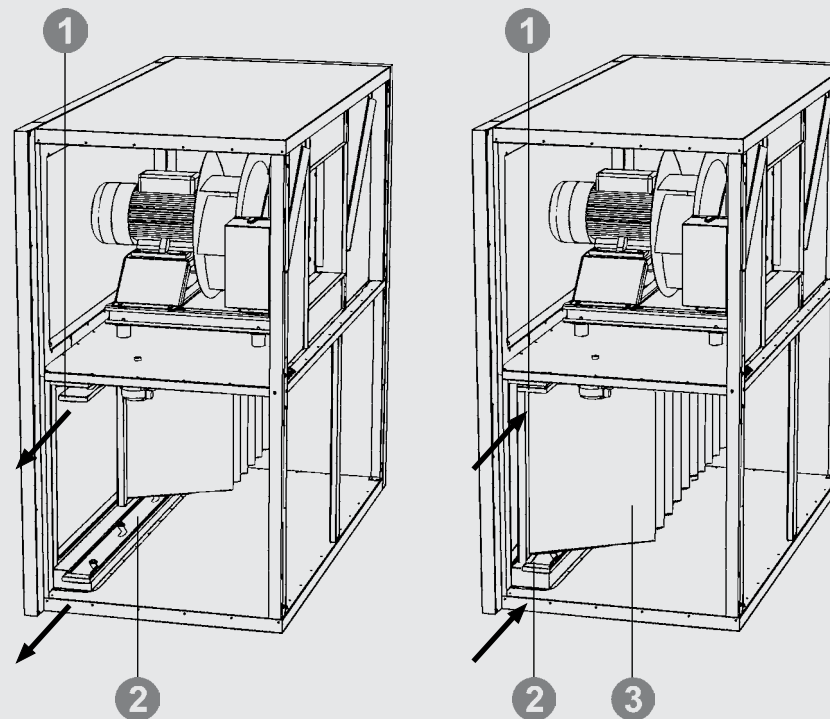

- 1 Upper filter holder
- 2 Lower filter holder
- 3 Changeable filter

VERSO Air Handling Units Construction

Water Air Heaters, Air Coolers, Direct Evaporation Air Coolers

Mostly used with aluminum plates (2.5; 3 or 4 mm fin pitch) and copper pipes.

Upon additional order can be assembled with plugged connection for frost sensor.

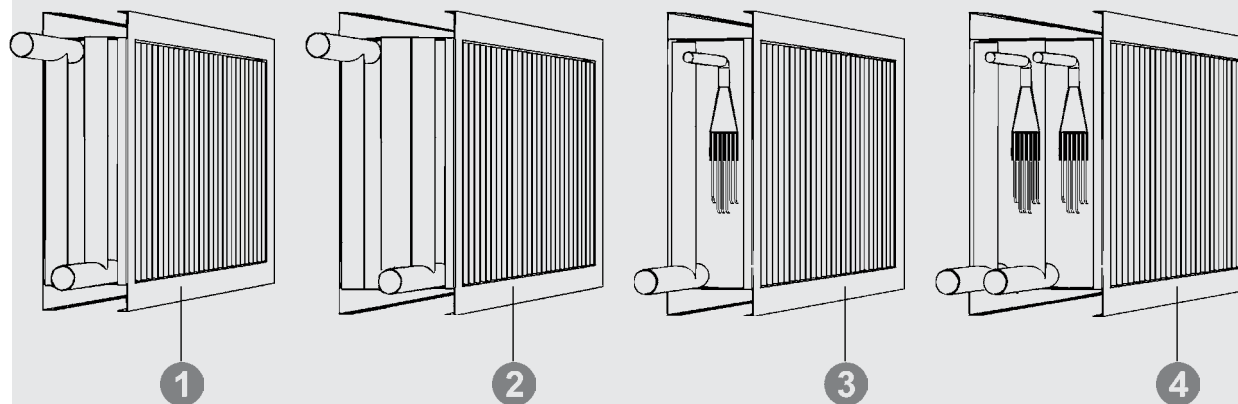

- 1 Water air heater
- 2 Water air cooler
- 3 Direct evaporation air cooler
- 4 Two-step direct evaporation air cooler

Water Air Heaters, Air Coolers, Direct Evaporation Air Coolers in VERSO-S Units

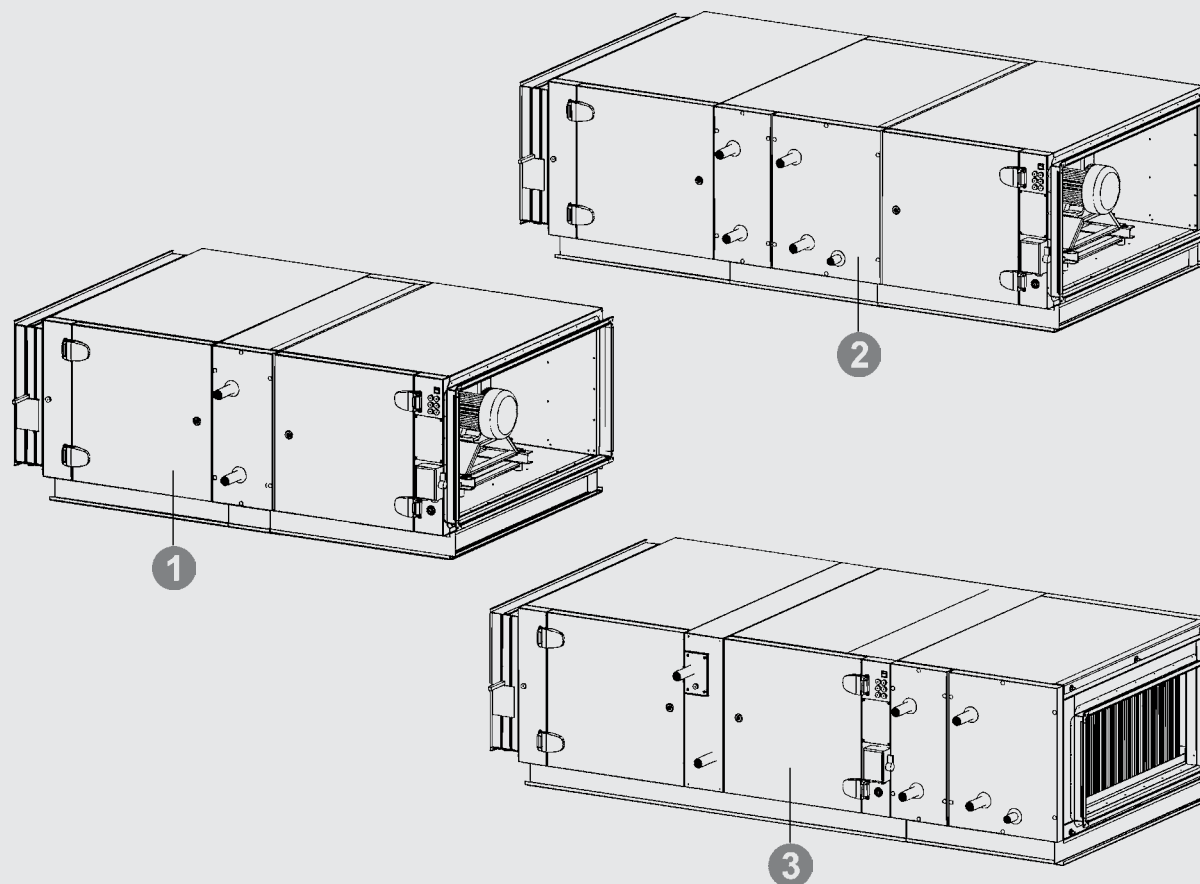

Possible VERSO-S composition options:

- 1 With the air heater mounted inside the unit
- 2 With the air heater and air cooler mounted inside the unit
- 3 With the air heater and air cooler and additional heater mounted outside the unit

VERSO Air Handling Units Construction

Air Heaters, Air Coolers, Direct Evaporation Air Coolers Mounted at the Bottom of VERSO-P, VERSO-R Units

The section of air heater, air cooler, or direct evaporation air cooler insulated in mineral wool is mounted on the outside of the unit. Therefore air handling unit takes less space and it is more convenient to install.

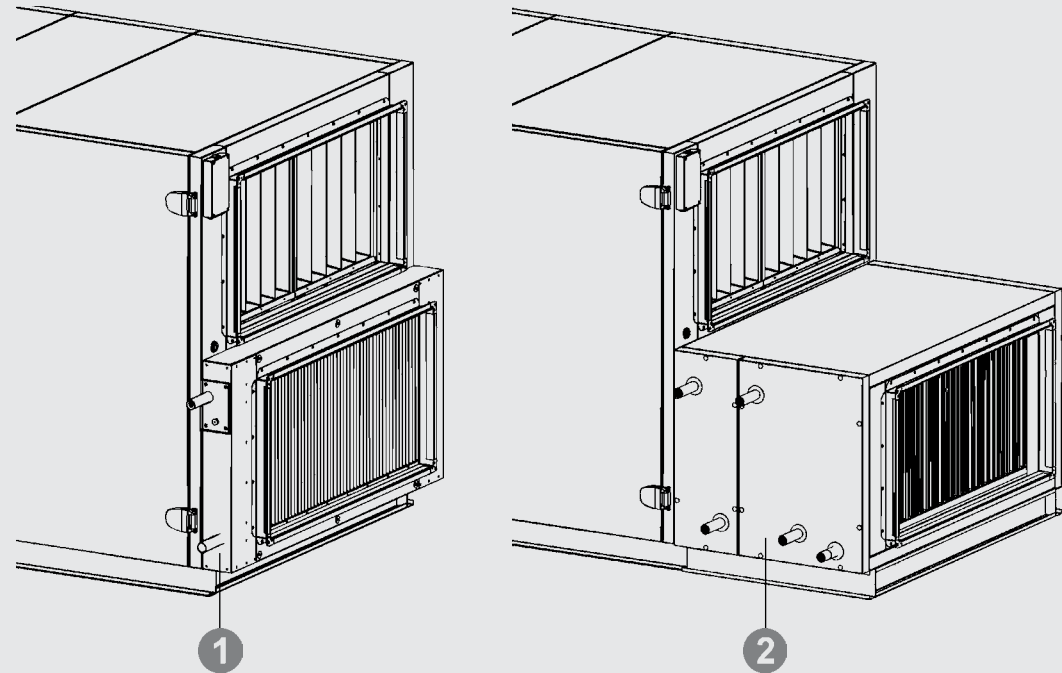

- 1 VERSO-R or VERSO-P with air heater installed outside the unit
- 2 VERSO-R or VERSO-P with air heater or air cooler installed outside the unit

VERSO Air Handling Units Construction



Air Heaters, Air Coolers, Direct Evaporation Air Coolers Mounting Types at the Top of VERSO-P, VERSO-R Units

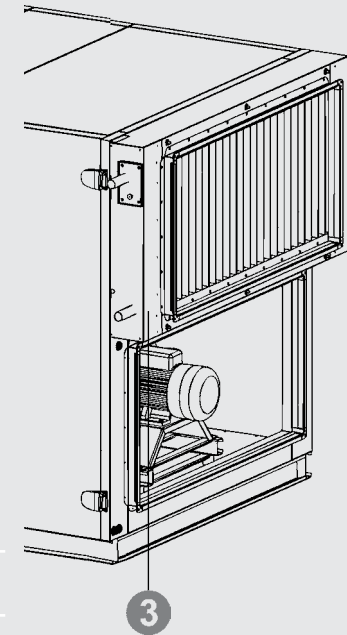
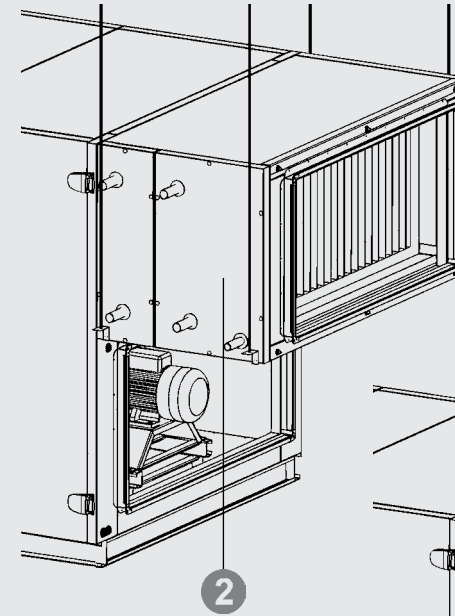
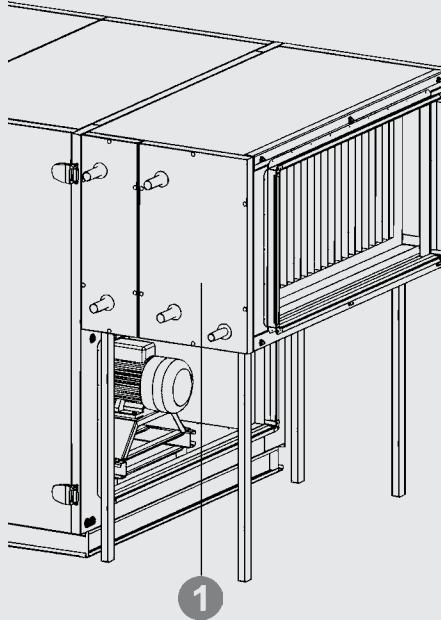

- 1 VERSO-R or VERSO-P with air heater and air cooler positioned on the welded frame outside the unit¹
- 2 VERSO-R or VERSO-P with air heater and air cooler suspended outside the unit²
- 3 VERSO-R or VERSO-P with a suspended air heater outside the unit

¹ base frame with legs for heat recovery section - only as additional set

² hanging bar - only as additional set

VERSO Air Handling Units Construction

Water Air Heater, Air Cooler, Direct Evaporation Air Cooler Connection to VERSO-P and VERSO-R Series Air Handling Units

When connecting heat exchanger to the system, it is necessary to use two pipe wrenches:

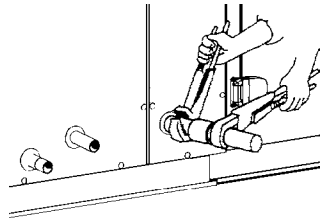

Be careful when exploiting hot water air heaters as the heating agent temperature may reach 130°C!



When operating air handling unit in the temperatures lower than 0°C, it is necessary to use glycol additionally!



It is important to maintain air heaters and coolers cleanliness; that is to change filters installed in the air handling unit on time. If the air heater or cooler gets dirty, to perform periodical cleaning.

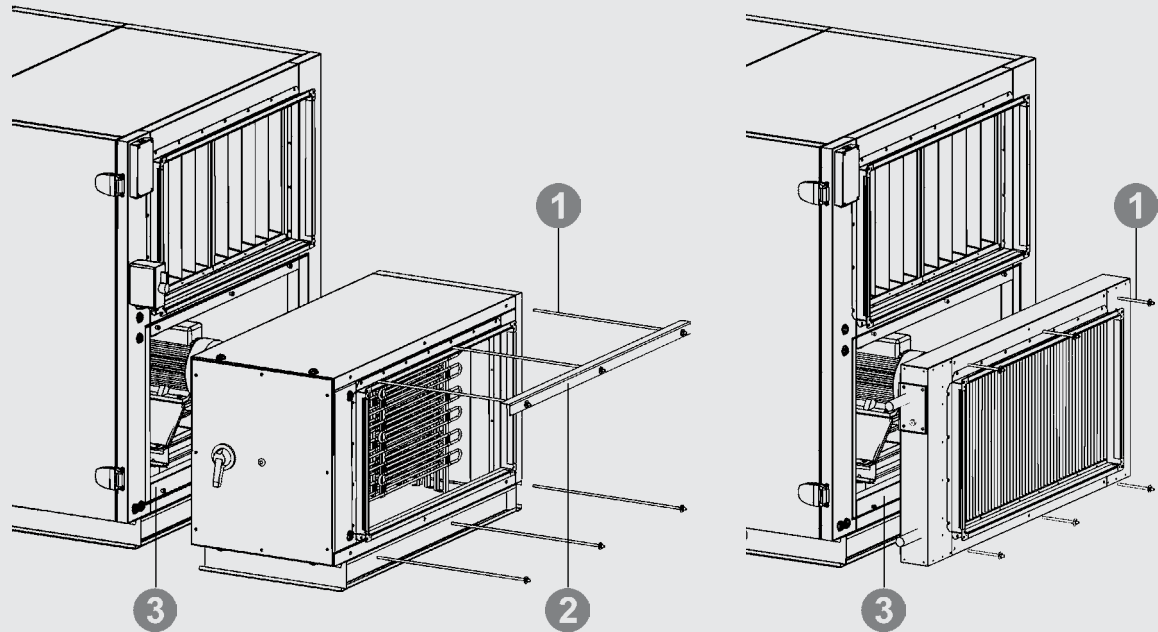

- 1 Water heater or direct evaporation air cooler mounting pin
- 2 Frame
- 3 Gasket

Electric Air Heaters in VERSO-S Series Air Handling Units

Electric heater is mounted as a middle section of an air handling unit.

Three interconnected unit parts are bolted together.



When heating capacity exceeds 45 kW, additional electric heater section may be used (also up to 45 kW). In such a case additional heater is connected to the supply air vent (after the ventilation section).



Each electric heater section has separate main-switch to which electric power supply is connected.

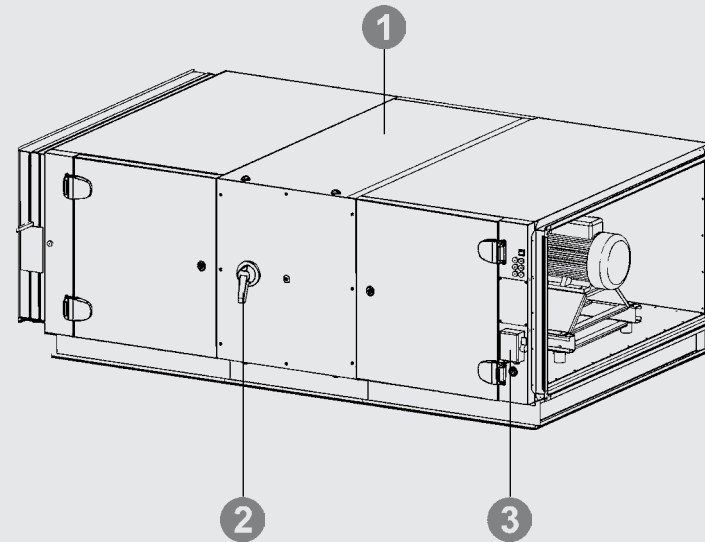

- 1 Electric heater
- 2 Heater main-switch
- 3 Unit main-switch

VERSO Air Handling Units Construction

Connecting Electric Air Heater to VERSO-S Series Air Handling Units

1. Before connecting and screwing together air handling unit parts, connecting cables with the connectors must be passed through the designed holes.
2. When sections are put together (20 cm gaps are left), one part of the linkage (A) passed through the openings.

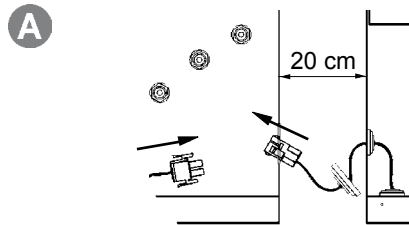

3. The opening place is sealed with a gum sealer and both ends (B) of the linkage are connected; sections are pushed together.

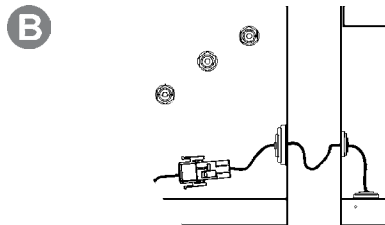

4. After sections are connected, electric power supply is connected to the heater main-switch (3). Cable is put through the sealant (2).

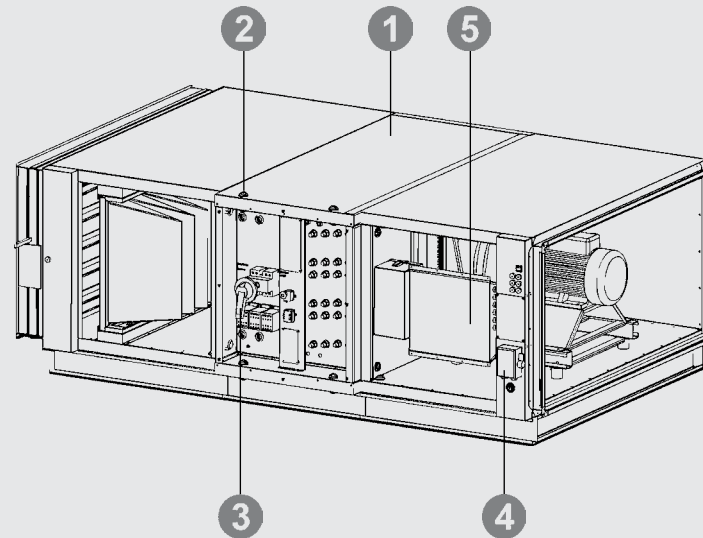

- | | |
|---|--------------------|
| 1 | Electric heater |
| 2 | Sealant |
| 3 | Heater main-switch |
| 4 | Unit main-switch |
| 5 | Control automation |

Electric Air Heaters in VERSO-P and VERSO-R Series Air Handling Units

Electric heater is mounted to the unit supply air vent and screwed to a side panel with pins.

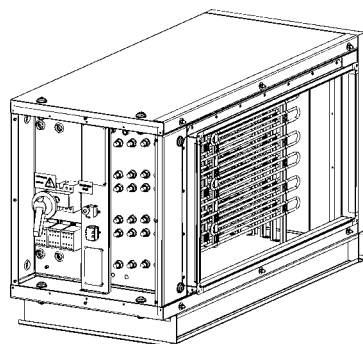

After electric heater is bend together the wires and cables connecting the unit and heater are connected together, electric power supply is connected.



Connection of the electrical power supply and other cables types is specified in the principal electric scheme!

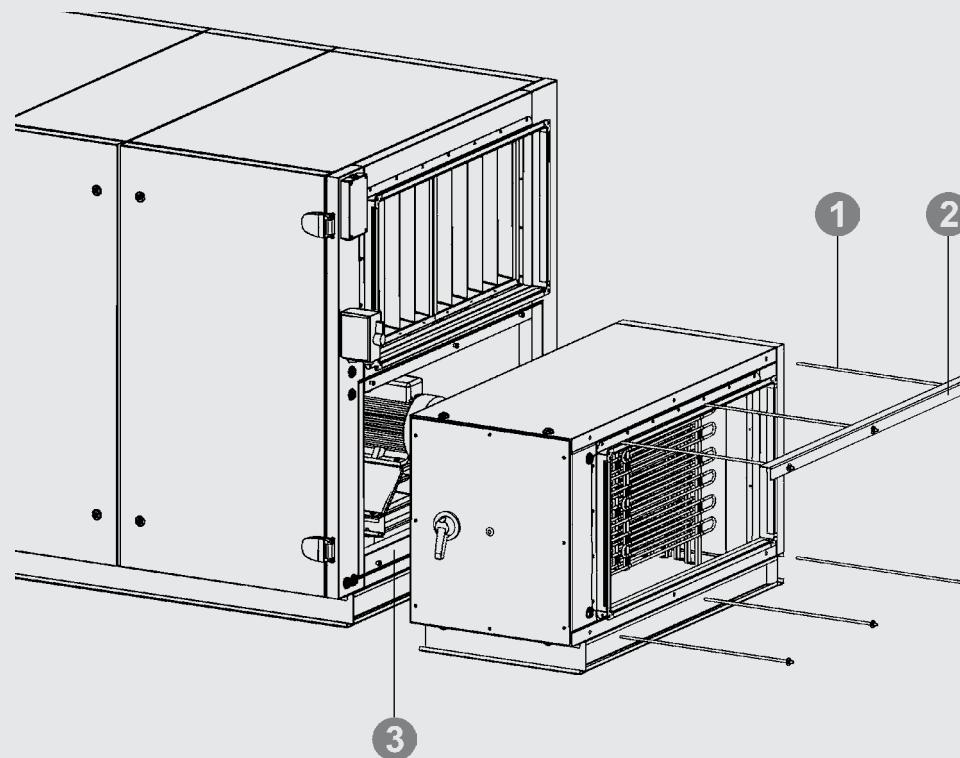

- 1 Pin, by which electric heater is mounted to the unit supply air vent
- 2 Frame
- 3 Gasket

VERSO Air Handling Units Construction

Electric Air Heater Connection to VERSO-P and VERSO-R Series Air Handling Units

- a) After opening doors of the air handling unit, linkage (4) connecting the heater and the unit is connected.
- b) Unit electric power supply is connected to the heater introductory main-switch (3). Unit electric power supply is connected. The cable is put through the sealant (1).



Before doing connections, make sure that the introductory main-switch is off or electric power supply is off.

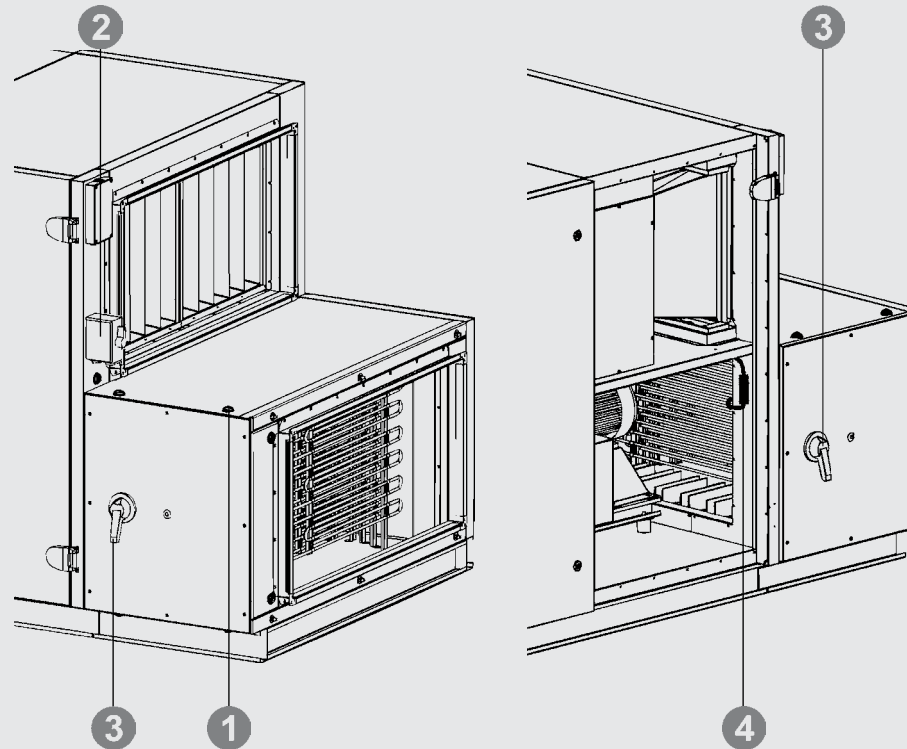

- 1 Sealant
- 2 Unit main-switch
- 3 Heater main-switch
- 4 Linkage connecting the heater and the unit

Electric Air Heaters Protection from Overheating

Three safety measures protect electric air heaters from overheating.

1. 90°C heater overheating protection. When airflow velocity is too low, it does not allow the heater elements to get hotter more than 200°C. Protection system works automatically, overheat is indicated on the remote control device.
2. 120°C heater overheating protection. After disconnecting electric power supply from the heater, protection is restored manually: the reset switch on the heater is pressed; overheating is indicated on the remote control device.
3. 70°C triac overheating protection. Heater control is terminated, protection resumed automatically, message is displayed on the remote control device.



There is a possibility to resume over-heat danger safety by pressing RESET button only if before reasons for the heater overheating are clarified and eliminated.

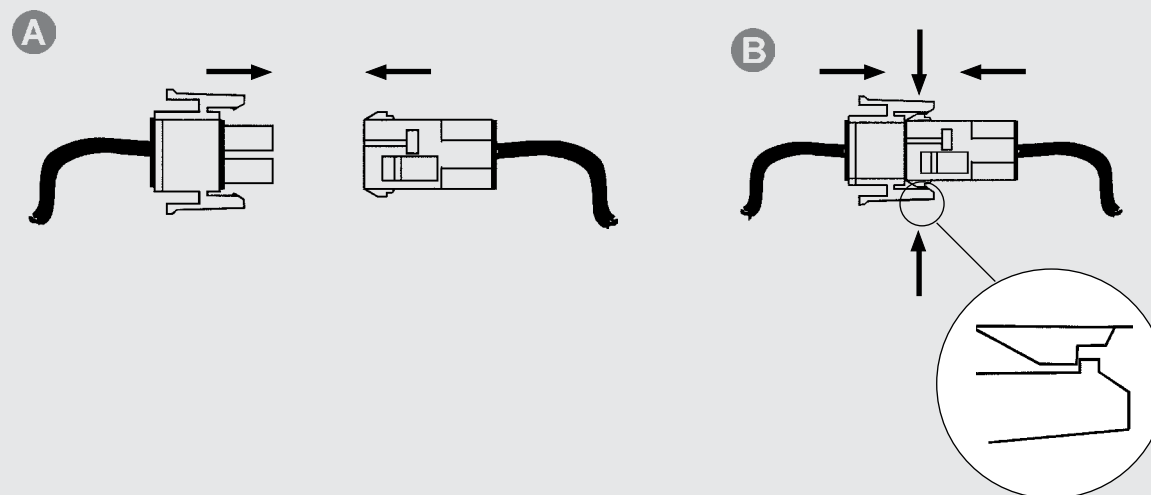

Linkages Connection

When connecting parts of the air handling unit and connecting electric heater, it is necessary to connect the linkages correctly. Connecting the cable, it is necessary to push together both parts of the linkage (A), to push them until the linkage's fixers (B) connect.

VERSO Air Handling Units Construction

VERSO Series Air Handling Units Designed for the Outdoor Use

VERSO air handling units, which are designed for outdoor use, can be additionally assembled with roofs with water drain tray to opposite viewing side. Every section has separate roof which must only be connected together.

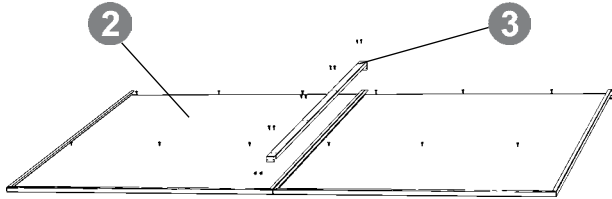

On the supply and exhaust air vents, there is a possibility to mount additional casings and external grills.

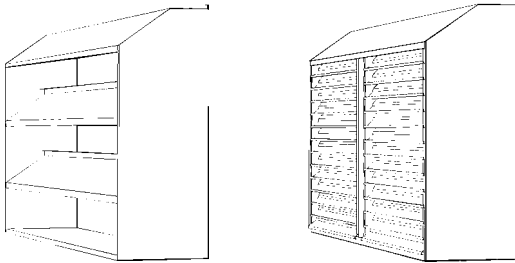

Joints need to be additionally sealed, if units are intended to be used outside. Sealant is not included in unit set.

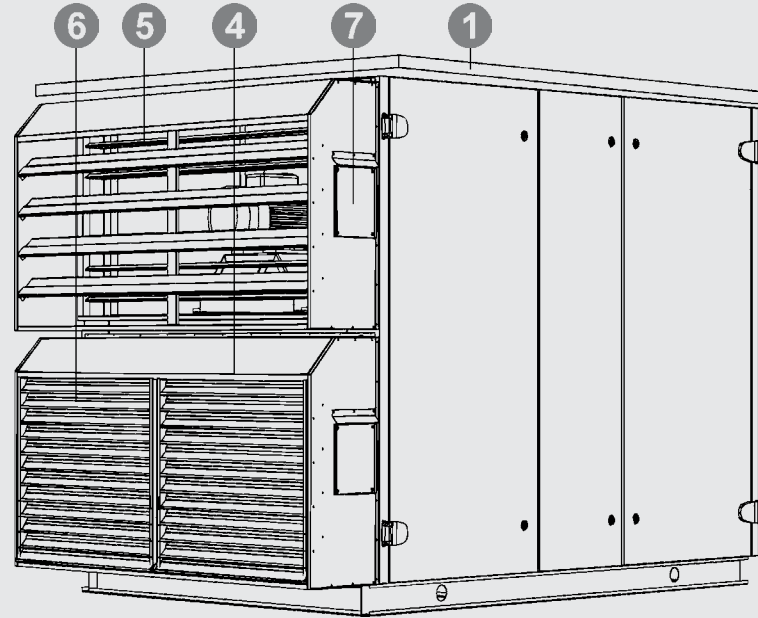

- 1 Roof
- 2 Roof plate
- 3 Roof plate fixer
- 4 Air intake vent casing
- 5 Exhaust air vent casing
- 6 External grills
- 7 Valve actuator cap

VERSO Air Handling Units Transportation

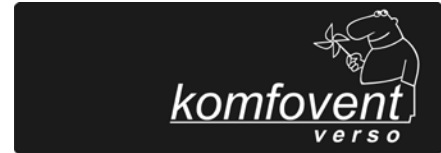

VERSO Air Handling Units Transportation by Crane, Lift Truck and Carts

The unit is transported separately.

While transported, each section is fixed to a wooden pallet and wrapped.

Dampers and flanges are supplied not fixed to the unit. They are on the top of each unit section. Sealing, connecting and fixing bolts are inside in each section. Base frame is separate from the unit during the transportation.

When unit is loaded or unloaded by crane, cargo rope is fastened in its designated places.

Lift truck or cart can transport air handling unit as it is shown in the pictures.

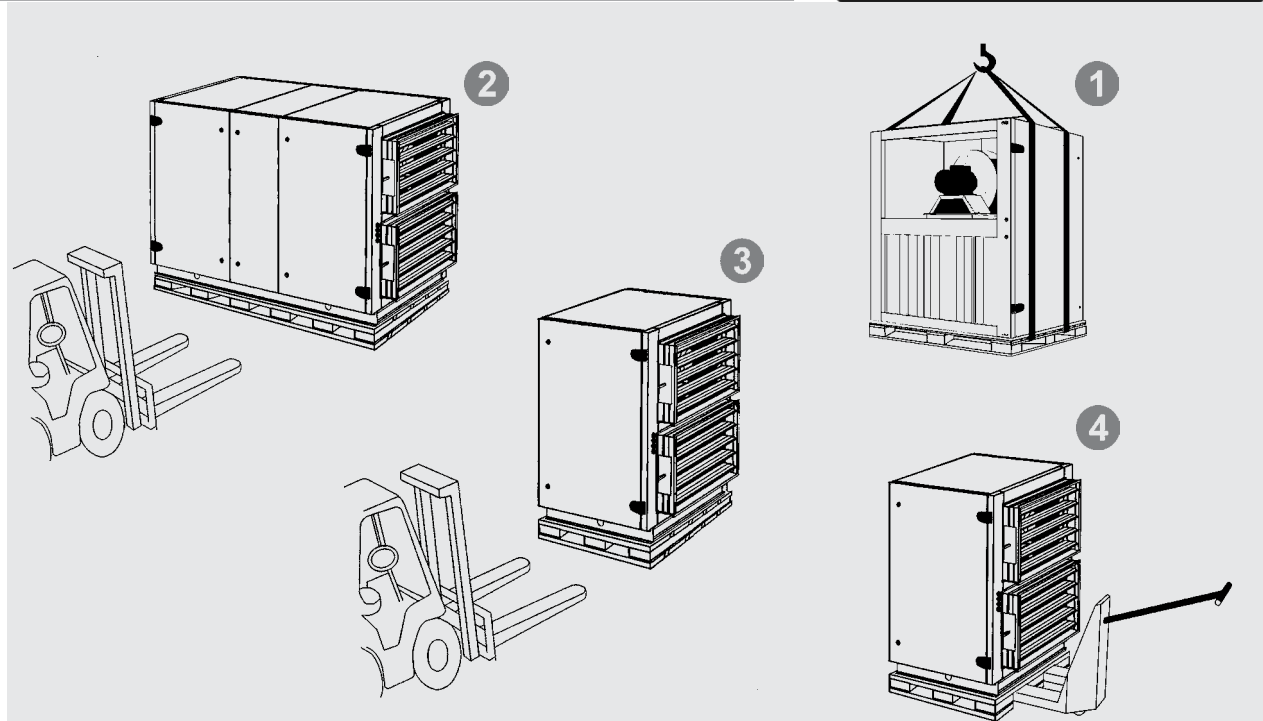

- 1 Separate unit part is lifted by crane on a wooded pallet
- 2 Unit is transported by lift truck on a wooded pallet
- 3 One section of the unit is transported by lift truck on a wooden pallet
- 4 One section of the unit is transported by cart on a wooden pallet
- 5 Carts on a wooden pallet transport the unit

VERSO Air Handling Units Maintenance Space

Maintenance space is needed for convenient inspection of the unit; perform maintenance works; when there is a need to pull it out for inspection, change parts of the unit or even the whole unit.

In order to change some unit components, there might be a need to demount the unit partially or completely.

The minimal unit maintenance space range is enough to change air handling unit filter.

Size of the unit	A	A _{min}	H	B
10	1000	850	500	500
20	1150	950	500	500
30	1300	950	500	500
40	1500	950	500	500
50	1700	950	500	500
60	1900	950	500	500
70	2100	950	500	500
80	2300	950	500	500



VERSO-P, VERSO-R air handling unit middle doors open up, only if the side doors are opened.

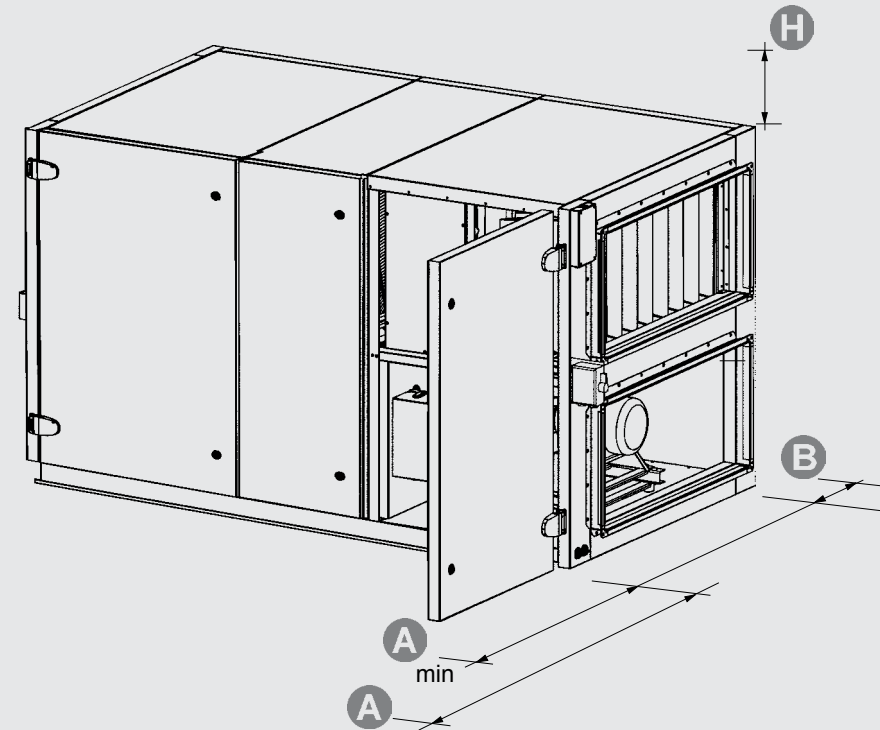

- A recommended space for the unit maintenance
- A_{min} minimal necessary space for the unit operation
- H free space over the installed air handling unit
- B recommended space behind the air handling unit

Setting and Installing VERSO Air Handling Units

Before installing air handling unit it is important to remove transportation elements. If the unit was transported not on the positioning frame, sections should be placed from wooden panels to positioning frame.

The unit is installed on even and solid base, location that was assigned to it. According to the unit weight, which is indicated in technical specifications, dimensions and other important parameters special construction calculations should be done.

If the unit is ordered with adjustable feet, unit can be leveled with its help.
Leveling up to 50 mm.



If the surface on which the unit is installed is not even, the air handling unit can distort, because of that doors may not close correctly, there may be gaps between jointed sections.

It is advisable to put a gum seal between the air handling unit and the base.



It is forbidden to install the air handling units one on the other.

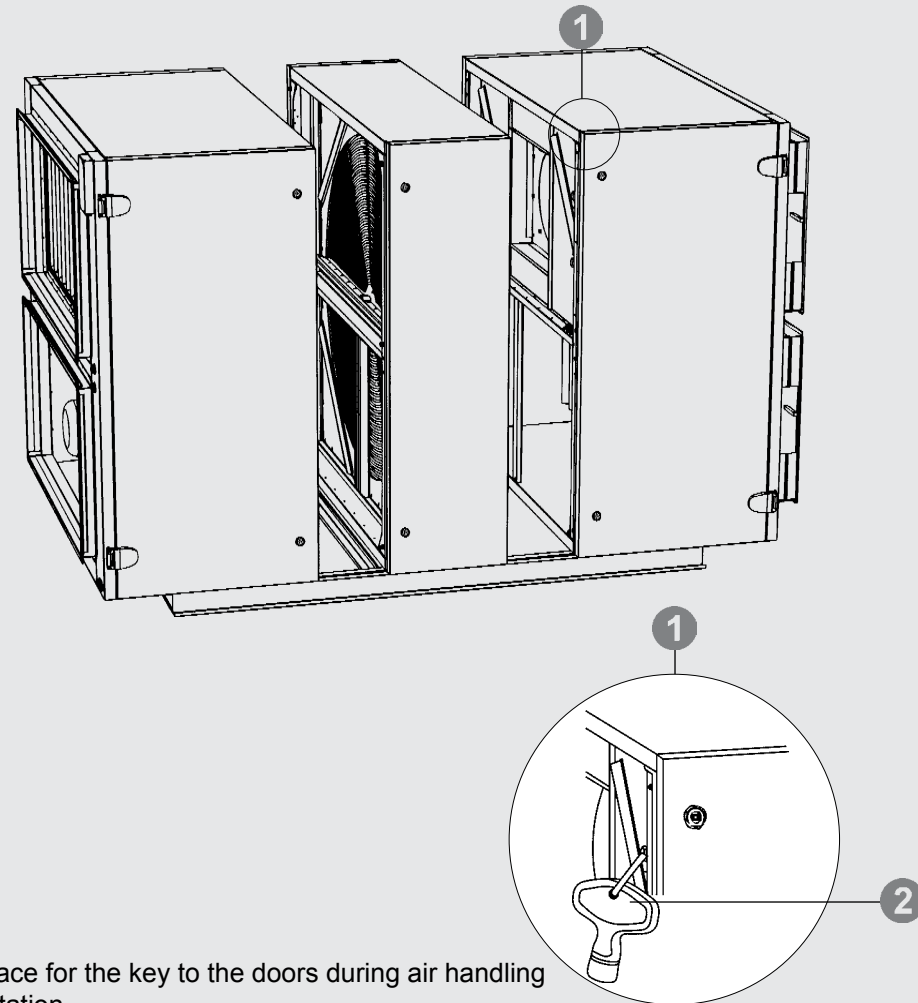

- 1 Fastening place for the key to the doors during air handling unit transportation
- 2 The key

VERSO Air Handling Units Electric connection

Sections Connection of VERSO-R and VERSO-P Series Air Handling Units

After the parts of air handling unit are mounted together, connecting cables and wires of the unit sections are connected together.

Electric connection of VERSO-R sections is done after rotary heat exchanger section is pulled out at 20 cm and by connecting the connecting cables to the side panels of the rotary heat exchanger construction (3).



Linkages are connected according to the numeration specified in the connection scheme or adequate markings. (See automation instruction).

VERSO-P sections' electrical connection is done by connecting the cables to the designed connections of plate heat exchanger section's construction. The linkages should be connected according to the numeration or adequate markings. Detailed connection procedures are specified in automation instruction.



Connection of VERSO-S sections is specified in the chapter on electric heater connection.

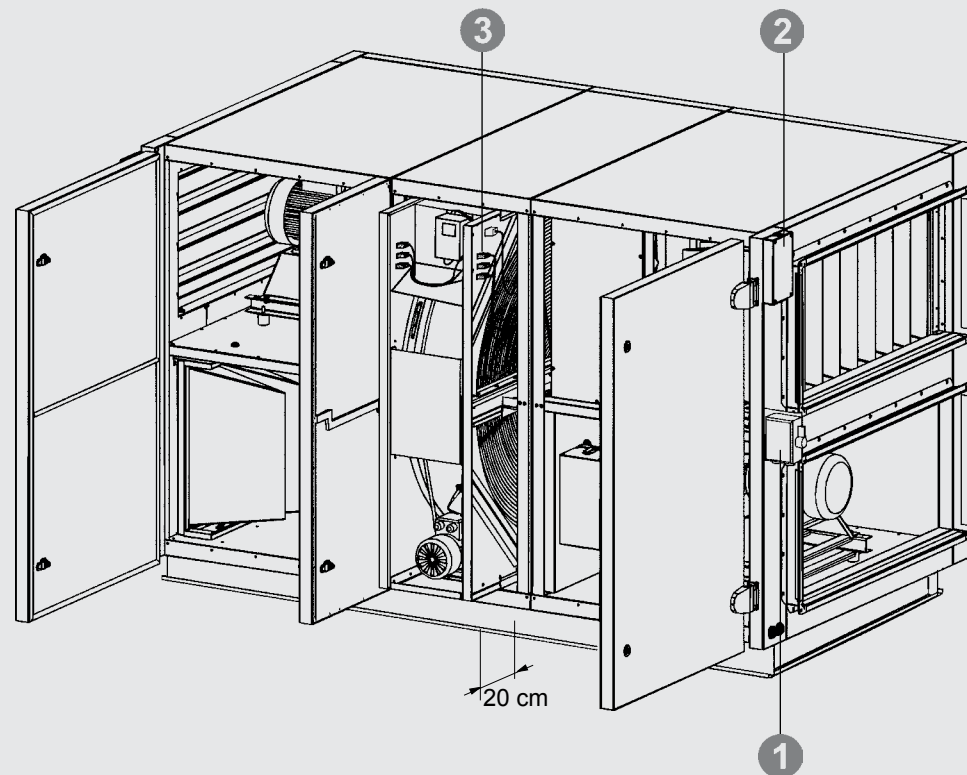

- 1 Introductory main-switch
- 2 Connection box
- 3 Connecting cables

Air Handling Units Electric Power Supply

Electric power supply is connected to the introductory main-switch (1), located on a side panel of the unit. If the unit is equipped with electric heater additional power supply needs to be connected to the heater main-switch (2).

External Elements Connection:

Connection box is located on a side panel of the air handling unit (3).

All the external automation elements are connected to the clips that are inside the box.

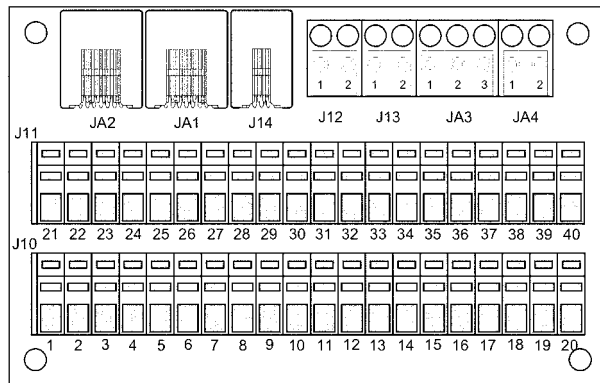

Detailed connection is specified in the control system manual.

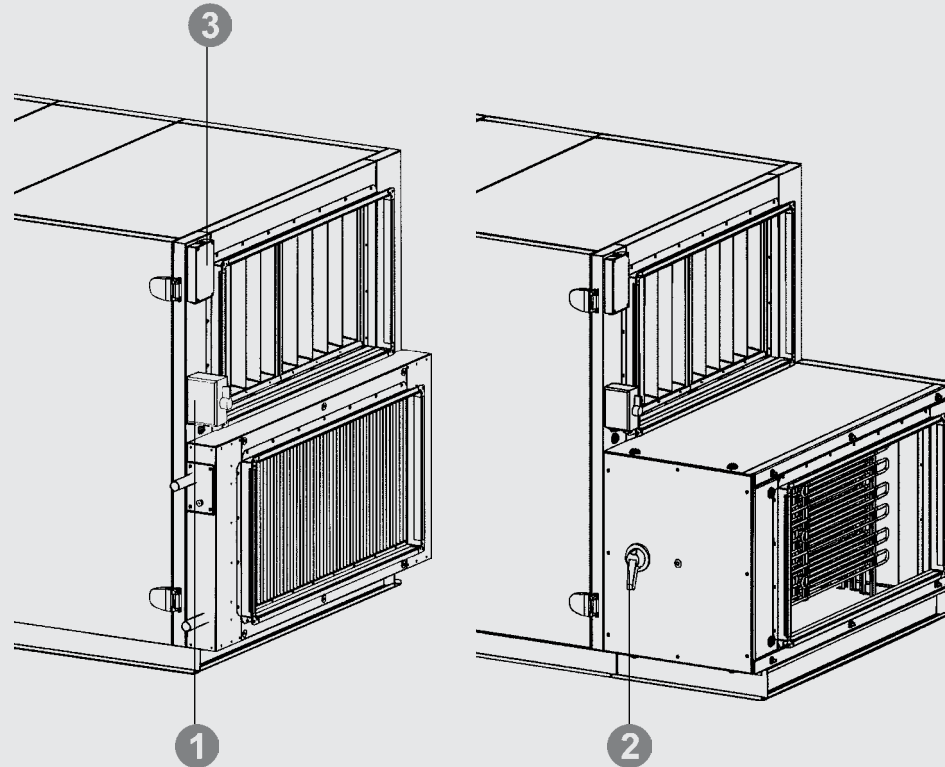

- 1 Introductory main-switch
- 2 Main-switches, which are inside the electric heater
- 3 Connection box

VERSO Air Handling Units Electric Connection

VERSO Air Handling Units External Elements Connection

VERSO-S	
Connecting clips	Projected connection
1-13	C2 controller
14, 15, 16	Temperature sensor for supply air
17, 18	Returned water temperature sensor ¹
19, 20	Fire alarm system of the building
21, 22, 23	Hot water mixing valve actuator ¹
24, 25, 26	Cold water mixing valve actuator
27, 28	Unit remote switching on or off
29, 30	Unit alarm indication
30, 31	Unit run indication
32, 33	Additional external device activation
34, 35, 36	Air damper actuator
37, 38	Water circulation pump ¹
39, 40	Cooler step control

VERSO-P and VERSO-R	
Connecting clips	Projected connection
1, 2, 3, 4	C3 controller
5, 6, 7	Air quality sensor ² (CO ₂ , humidity or other)
8, 9, 10	Recirculation damper actuator ³ (if projected)
11, 12, 13	Recuperation by-pass damper actuator ³
14, 15, 16	Supply air temperature sensor
17, 18	Returned water temperature sensor ¹
19, 20	Building fire alarm system
21, 22, 23	Hot water mixing valve actuator ¹
24, 25, 26	Cold water mixing valve actuator
27, 28	Unit remote switching on or off
29, 30	Unit alarm indication
31, 32, 33	Exhaust air damper actuator ³
34, 35, 36	Supply air damper actuator ³
37, 38	Water circulation pump ¹
39, 40	Cooler control (1 step)
41, 42	Cooler control (2 step)
43, 44, 45	Supply air pressure external sensor connection ²
46, 47, 48	Exhaust air pressure external sensor connection ²

¹ used only in the units with water heater

² additional function

³ external actuator connection (not used in VERSO units)



Before doing connections make sure that the introductory main-switch is off or the unit is disconnected from the electric power supply network.

VERSO Air Handling Units Connection to the Air Ducts

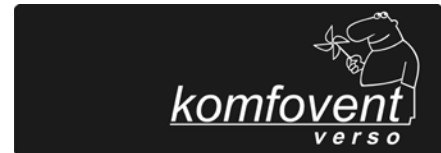

VERSO Air Handling Unit is connected to the Air Duct in Two Ways

Air ducts are connected to VERSO units through L-20 connectors.

VERSO units of size 60, 70, 80, are connected through L-30.

Air damper connection to the air duct

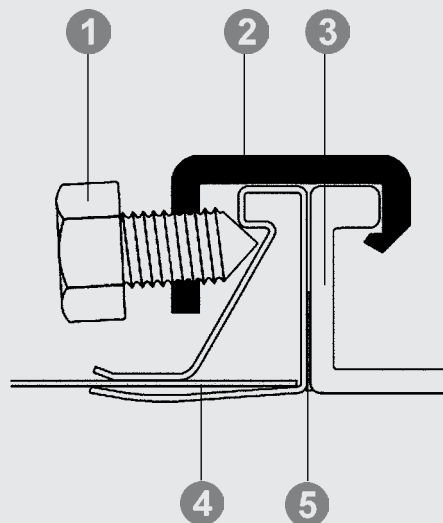

- 1 Bolt
- 2 Filter clamp
- 3 Air handling unit connection
- 4 Air duct flange
- 5 Single-sided adhesive gasket

Flange connection to the air duct

Screwed bolts M8x20 in the corners.
Special adhesive gasket ensures tightness..

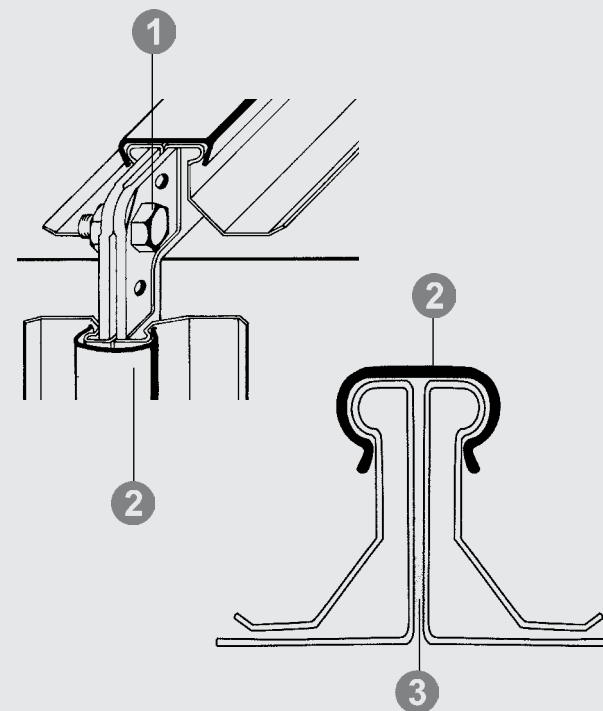

- 1 Bolt
- 2 C profile for flange connection
- 3 Single-sided adhesive gasket

VERSO Air Handling Units Sloping Drain Tray



Attention: water traps should be installed on each sloping drain tray collector nipple, so that the sloping is completely eliminated from the air handling unit and an unpleasant smell from the discharge does not get into the air handling system.

Water trap has to be attached to each nipple.



If the air handling unit is operated outdoors, it is necessary to heat water trap and sloping drain tray pipes with electric heating cable (when outside temperature is $t < 0^{\circ}\text{C}$). Water trap and sloping drain tray pipes have to be wrapped in insulation material.

Siphon with the spherical valve

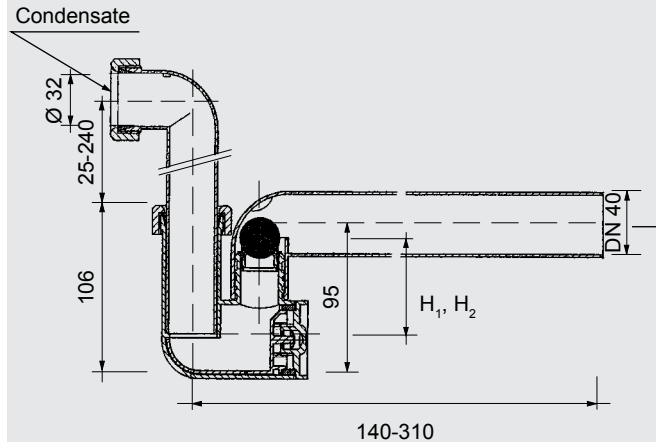

Siphon without the valve

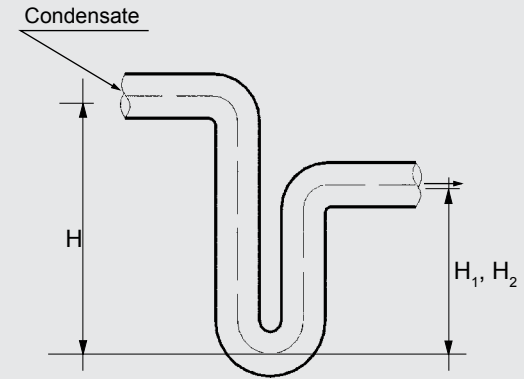

Pressure fan generates, Pa	Dimension H, mm	Dimension H ₁ , mm	Dimension H ₂ , mm
<500	120	60	60
500-1000	200	80	110
1000-1400	270	110	150
1400-1800	350	150	190
1800-2200	430	190	230

H₁ – in the air handling unit section to which the siphone is connected, static pressure is negative
 H₂ – in the air handling unit section to which the siphone is connected, static pressure is positive

VERSO Air Handling Units marking: warning



Note!
Important information in
the instruction manual

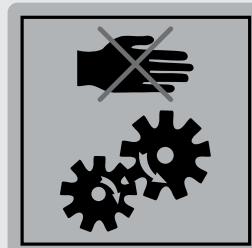

Caution!
Rotating parts!

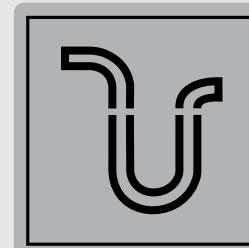

Place for siphon

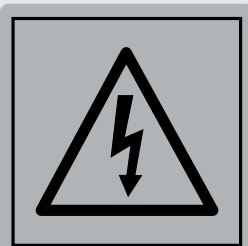

Note!
Before performing any
inspection work inside the
unit, be sure the unit's
electric power supply is
disconnected

VERSO Air Handling Units marking: informative

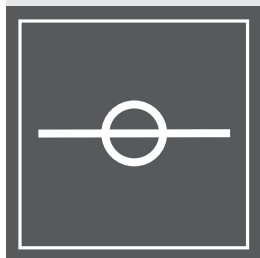

Air damper



Water air heater.
Electrical air heater



Noise attenuator



Air filter

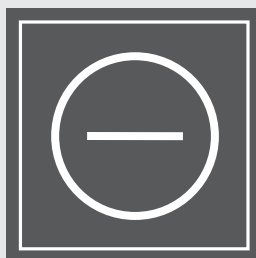

Air cooler

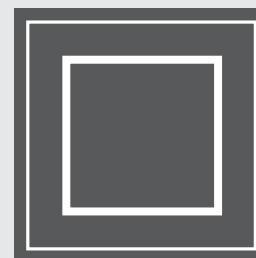

Inspection

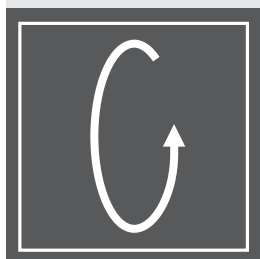

Rotary heat exchanger



Fan

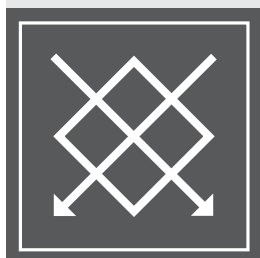

Plate heat exchanger



Air humidifying section

Check-up before turning on VERSO Air Handling Unit



- Before turning on air handling unit, clean installment dust and waste.
- Check whether cable and wires are connected firmly.
- Take off the unit all supporting shields and covers and other things left after installment of the unit.
- Before turning on the unit, it is necessary to close all the doors and bolt all protection shields.
- Check whether air dampers open and close properly.
- Check whether heat exchangers are connected tightly.
- The air handling unit can be turned on only according to projected control system order (if the air handling unit has the manufacturer's automation, see control system instruction).
- If the air handling does not have manufacturer's control system, the company installing control system is responsible for the unit's functioning and safety reliability.
- Before operating the unit air handling system tune-up works must be performed.

Noise Caused by VERSO Air Handling Units

Air handling unit causes some acoustic noise (more specific data is available in the technical unit specification) and this has to be taken into consideration when installing air handling unit. Comfort in the facilities depends not only on the air handling unit, but also on the quality of the ventilation system, installment quality and other factors (noise reduction means and etc).

Recommended:

- To install air handling unit not closer than 500 mm from a wall (if needed - use additional noise reducing materials, for example, layers of mineral wool).
- Make sure that vibration from the air ducts does not transmit to the building construction; therefore it is recommended to use flexible connectors, absorbing air duct holders. Air ducts must be selected so that air flow would not create additional noise and vibration.
- Air handling unit has to be installed on a fairly massive and solid base, considering mass of the unit and the construction standards. It is recommended to lay gum sheets between air handling unit and the base.

Warranty is not valid if the unit was installed or operated improperly, or it was damaged mechanically, also if the unit constituent parts are changed unauthorized or operation conditions are not suitable (aggressive environment, humidity, etc.)

It is forbidden to destroy wilfully air handling unit sections frames, fan, motor, or other air handling unit parts during warranty period. If this requirement is not followed, the unit will not be serviced under the warranty service conditions.

When operating the unit, periodical air handling unit checks-ups by the user should be recorded in the Technical Service Register. Qualified specialist authorized by the user should make the entries.

When operating the air-handling unit, most important is to check the components that get dirty the soonest (for example, filters, heat exchangers, etc.). Periodical check-ups of the air handling unit are done every 4 months. During the check-up the heat exchanger condition is checked, whether the condensate drainage siphon and other components of the air handling unit are not dirty. When the filters are dirty, the warning system informs about it, such system has to be installed when installing the unit.

Check-ups and technical service has to be performed by the qualified specialists.

It is necessary to follow the instructions of heating system, during exploitation period of the unit.



Specific warranty conditions are in unit warranty list.



UAB AMALVA

Ozo str. 10, LT-08200 VILNIUS, LITHUANIA

e-mail info@amalva.lt www.amalva.com www.komfovent.com

2009