

## **VERSO-S** Series Air Handling Units with C2 Control System Electrical Installation and Operation Manual



# Table of contents

<b>1. INSTALLATION MANUAL</b>	<b>4</b>
1.1. Air Handling Units Sections Connection	4
1.2. Electric Power Supply Connection	4
1.3. External Elements Connection	4
1.4. Temperature Sensors Installation	6
1.5. Control Panel Installation Requirements	6
1.6. Control Panel Connection	6
<b>2. OPERATION MANUAL</b>	<b>7</b>
2.1. Unit Control	7
2.2. Switching on the Unit	7
2.3. Control Panel Indication	8
2.4. Unit Programmable Settings	8
2.5. Other Control Functions	12
2.6. Troubleshooting	13
Unit Functional Diagram	15
Specification	16
Wiring Diagram	17

# Installation manual

## 1. INSTALLATION MANUAL

Installation works can be performed only by the specialists that have required qualification. During installation following requirements must be fulfilled:

 It is recommend to lay control circuit cables separately from power cables, minimum distance must be 20 cm.

### 1.1. Air Handling Units Sections Connection

After unit parts have been connected together (if the unit consists of several sections), unit sections connecting cables and wires are connected.

 Connector connection is performed strictly according to numeration given in wiring diagram, or adequate markings (see unit electric scheme).

 When disconnecting unit sections, do not pull by connecting wires and cables!

### 1.2. Electric Power Supply Connection

If the air handling unit voltage is ~230V; 50 Hz it is necessary to install the socket with grounding of corresponding capacity. If the voltage is ~400V; 50 Hz, the cable of electrical power supply is connected to the power supply terminal blocks, which are located on the unit's outside wall. It is necessary to connect earthing! Types of cables of connection of electrical power supply are specified in 1.2 Table:

Types of cables of connection of electrical power supply are specified in 1.2 Table:

1.2 Table

Electrical Power Supply Cable Types

Current, A	Cable Type
15	5 x 1,5 mm <sup>2</sup> (Cu)
21	5 x 2,5 mm <sup>2</sup> (Cu)
27	5 x 4,0 mm <sup>2</sup> (Cu)
34	5 x 6,0 mm <sup>2</sup> (Cu)
50	5 x 10,0 mm <sup>2</sup> (Cu)
70	5 x 16,0 mm <sup>2</sup> (Cu)
85	5 x 25,0 mm <sup>2</sup> (Cu)

 Unit must be connected to the stationary installation by solid cable though circuit breaker with maximal 300mA current leakage protection.

 Before connecting unit to the electrical power supply, it is necessary to check whether earthing has been installed properly.

### 1.3. External Elements Connection

On the air handling unit wall it is provided connection box. To the terminals which are inside the box (1.3 Picture) all external control elements are connected. External elements connection diagram is given in the 1.3a Picture.

1.3 Picture

Connection Board C2-P1

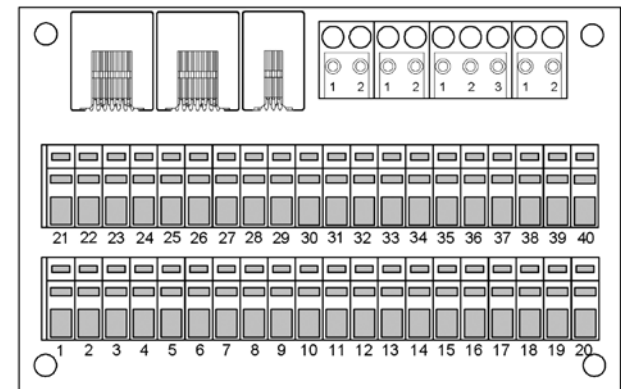

The air handling unit is equipped with season (WINTER/SUMMER) switch, located on the outside unit's wall near external connections board.

Applicability of the switch:

- In the air handling units with an electrical heater, during winter time heating function is switched on (position **I**) and during summertime for economy of the electric energy is switched off (position **0**).
- In the air handling units with hot water air heater, the circulation pump is switched on (position **I**) or during summertime switched off (position **0**).



# Installation manual

## 1.4. Temperature Sensors Installation

Supply air temperature sensor is mounted in the air duct in a projected place for it; after heater or cooler section (if provided). The minimal distance from the air vent of the unit up to the sensor should be not less than double diameter of the circular connection or a diagonal of rectangular connection.

Water temperature sensor is mounted on the return water pipe, as close as possible to the heater case. Sensor must be thermo insulated!



Temperature sensors and control panel connections must be sealed with PVC isolation tape.

## 1.5. Control Panel Installation Requirements

1. Control panel must be installed in the room under given following conditions:
  - 1.1. ambient temperature range 0°C ... 40°C;
  - 1.2. relative humidity limits 20% ... 80%;
  - 1.3. protection must be ensured from accidentally vertically falling water drops (IP X2).
2. Installation height must be not less than 0,6m from the ground.
3. Control panel connection is projected through the hole in its backside.
4. Control panel is fixed after screwing two holes on the fastening surface.

## 1.6. Control Panel Connection

Panel connection terminals position is shown in the 1.6 picture (on the right side).

1.6 Picture

Control Panel Diagram

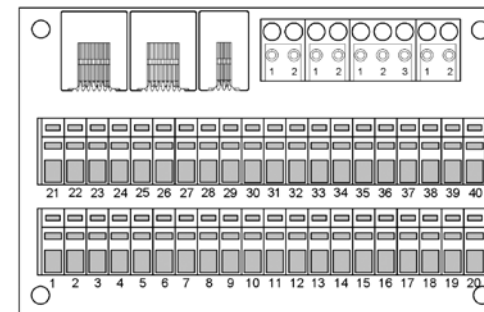

Control panel is connected to the connection box terminals (see 1.3 Picture). The length of the cable connecting the control panel with the unit should not exceed 20 m. Cable type is specified in unit wiring diagram.



Control panel connection and other cable thicknesses are specified in the wiring diagram!

## 2. OPERATION MANUAL

### 2.1. Unit Control

Air handling units control system ensures control of the physical processes that are taking place inside the air handling unit. Automatic control system consists of:

- the C2 controller which is integrated into a control panel;
- control boards mounted inside the unit;
- external connections board for automation elements which is located on the outside unit's wall;
- damper actuators;
- pressure and temperature sensors.





The control panel (2.1 Picture) can be installed in any user friendly place and is intended for remote control of air handling unit. Control panel display allows monitoring supply air temperature, unit operation modes and other. Control panel red light diode indicates unit failures. Air temperature, ventilation intensity, operation modes and other parameters are set by the buttons.

2.1 Picture

General View of the Control Panel

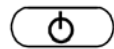

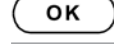

#### Buttons located on the control panel mean:

-  start up / shut down of the air handling unit;
-  entry to parameters change menu/ return to main menu;
-  parameters setting;
-  parameters confirmation;
-  navigation in the menu / parameters value change.
- 

### 2.2. Switching on the Unit

After connecting the unit to the electrical power supply, on the control panel displays start-up window, this is shown in the 2.3 Picture.

Unit is switched on (off) by pressing and holding for 4 - 5 seconds  button. After switching on, unit will start operating after short delay, until air dampers open up, and fans start running. Unit operation is indicated in the control panel by ventilation intensity level and operation symbol (see further).

 Do not switch on the unit without connected earthing! Make sure, whether all unit sections (if intended) are tightly interconnected.

# Operation manual

## 2.3. Control Panel Indication

The information is presented to the user on the display of a control panel by means of numbers and symbols, also light signals of a red light emitting diode.

Controller panel display start-up window is shown in the 2.3 Picture.

2.3 Picture

Control Panel Start-Up Window

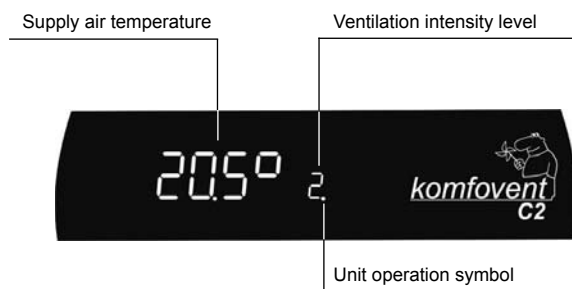

✓ **Note:**

If after powering the unit up and pressing the start up button the sign “Stop” is lit on the control panel display and the unit does not start it is necessary to follow the troubleshooting table (see below)

### Light Diodes Indication:

1. supply air temperature is displayed only – unit has been stopped;
2. supply air temperature, ventilation intensity level and unit operation symbol are displayed – unit is operating in manual mode;
3. the same as listed in previous item, only instead ventilation intensity level the letter “A” is displayed – unit is operating in automatic mode;
4. supply air temperature and unit operation symbol are displayed only – the unit operates in an automatic mode, but according to programmed working schedule it is stopped;
5. the red diode is flashing – see 2.6. chapter.
6. the red diode is flashing and/or “Stop” sign is shown – the emergency shutdown of the unit (see 2.6. chapter);
7. nothing is showing on the control panel – unit does not have electric power supply or control panel connection cable is damaged.



## 2.4. Unit Programmable Settings

After pressing button **MENU** on the control panel, and holding it pressed for 4 seconds, enter the menu mode. By pressing buttons **▼**, **▲** menu window is selected (see description further).



✓ **Note:**

Menu is escaped the same way by pressing and holding **MENU** button for 4 seconds, or waiting for 2 minutes till start-up window appears automatically.

## 1. Ventilation intensity setting

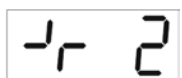
Ventilation intensity level choosing possibility is provided in the unit. To set ventilation rate, select menu window with ,  buttons:

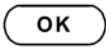

 – ventilation intensity level

Button  lets to enter the menu of ventilation intensity adjustment, and by buttons ,  the necessary level from 1 up to 10 (in some units adjustment of levels only from 1 up to 3 is provided) can be chosen. To confirm the selected level, press  button.





### ✓ **Note:**

After setting on the control panel maximal ventilation intensity level (10), on the start-up window is shown only digit 9.

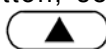

## 2. Supply air temperature setting

The air handling unit maintains the supply air temperature preset by the user. To set the temperature value, select menu window with ,  buttons:

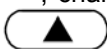
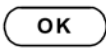







 – supply air temperature (set point)

Mark the first temperature-setting symbol with  button, set the required value with  or  button. Shift to the other symbol by pressing , change the value of the symbol with , . To confirm the selected value of the supply air temperature, press the  button.

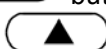
## 3. Setting the time and the day of the week



For the unit to operate properly in automatic mode, the time and the day of week should be set. For the purpose, select menu window with ,  buttons:

 – time and day of the week



Mark the first symbol with  button, set required value with  or  button, then mark the next symbol with  button, etc. Pressing  after the time setting, the small digit standing for the day of the week starts flashing. Press ,  buttons to select the day. In order to confirm the entered day and time, press  button.

# Operation manual

## 4. Weekly schedule setting

For setting the weekly schedule for automatic operation mode of the air handling unit, select menu window with ,  buttons:





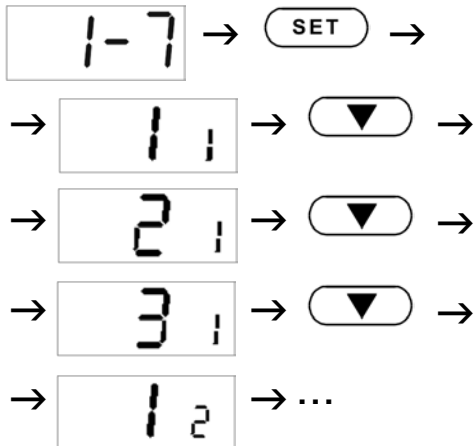

By pressing  weekly operating schedule programming is entered. For each day (twenty-four hours) it is possible to program 3 events. Press  or  button to select the needed event for the day of the week:







The big number stands for the event number, and the small one for the day of the week. After selecting the event (period) to be set press  button, and so it is proceeded for the set up of the starting time of the selected event: nustatymo:

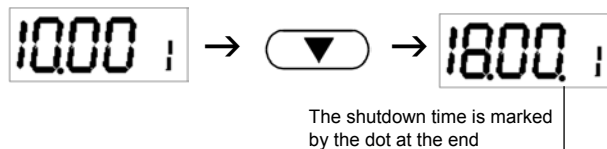

By further pressing  button all numbers are selected. The value of the flashing number is being changed by ,  buttons. After setting the time of the start point of the unit the window for the time of the switching off (ending) is selected by pressing  button:



By pressing  button all numbers are selected. With ,  the values are changed. By pressing  button the unit comes back to the previous window to select the day of the week, and same previously stated moves are performed. After setting the weekly schedule, the  button is pressed once again to come back to the previous menu

✓ **Note:**

*Times of not usable events must be set to zero if you use not all events of week day.*

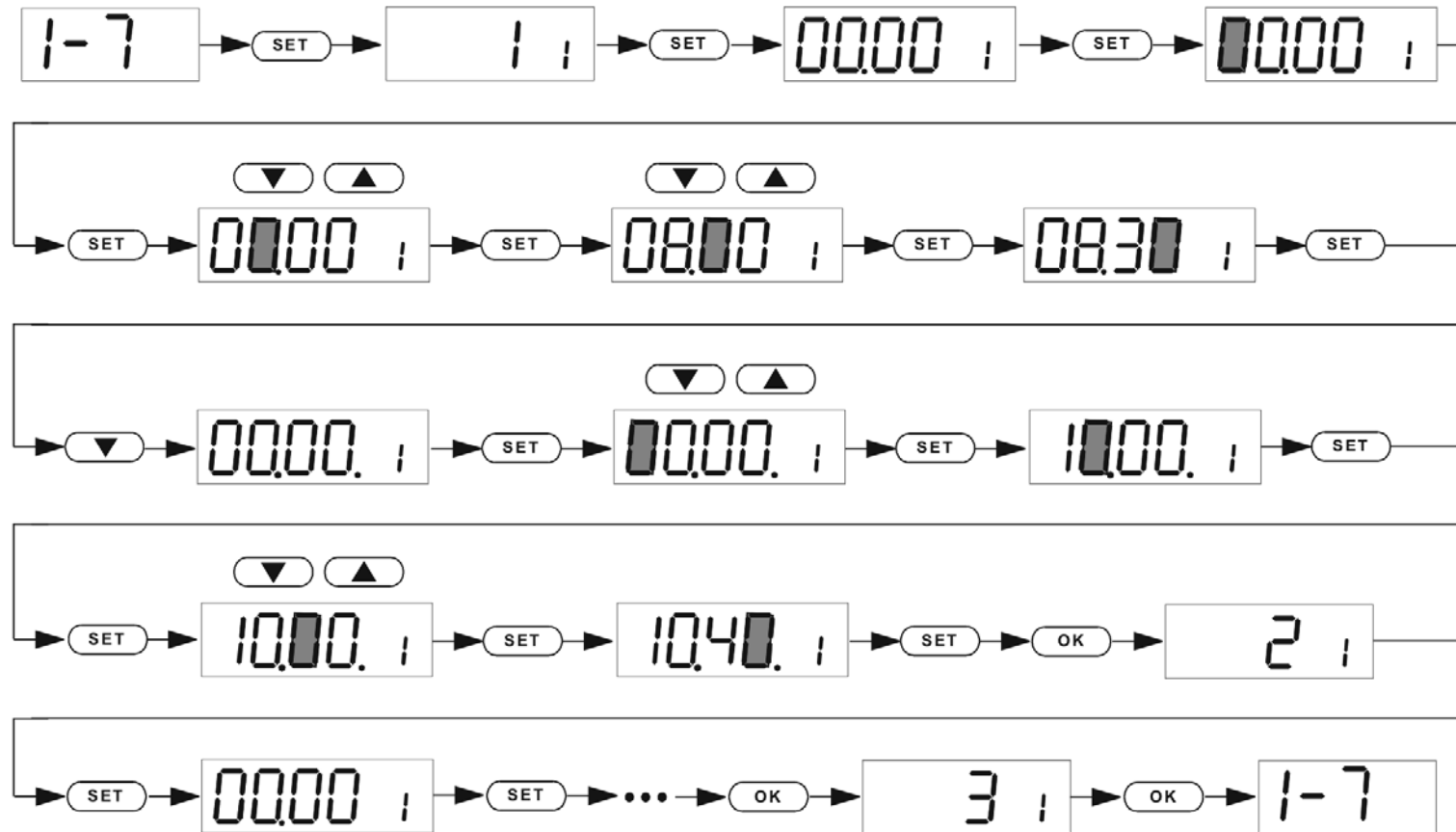

The example of setting the weekly schedule



# Operation manual

## 5. Unit operation mode setting



Two unit operation modes are available: manual and automatic. The unit performs in the manual mode all the time till it is switched off by pressing  button. The unit performs in automatic mode according to weekly schedule (see the above weekly schedule setting).

To set the operation mode the menu window is selected with ,  buttons:

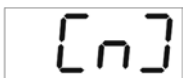

or – unit operation modes

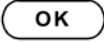
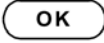

The operation mode is set by pressing  button, with ,  buttons the needed mode is selected: automatic **A** or manual **n**. The  button is pressed to confirm the mode. .

## 2.5. Other Control Functions

### 1. Remote switching on and off the unit

Unit is provided with remote switching on and off possibility by the additional device (the button, the timer, other sensor), which is connected to connection box contacts (see 1.3. chapter).

Closing (shortcut) contact 27 and 28 will switch on the unit, and having opened them – will switch unit off.

 If the unit is switched off by the button on the control panel, unit start up is not possible by means of remote device!

 Remote unit switching on and off function operates only in unit's manual mode!

✓ **Note:**

If unit remote switching on and off function is not used, contacts 27 and 28 must be closed.

### 2. Remote unit failure indication

In the connection box (see 1.3. chapter) contacts 29 and 30 are provided for connection of unit's emergency stop indicating devices, for ex. bulb.

### 3. Remote indication of unit operation

If it is necessary to have the information about the unit operation (when it works, and when it is not), there is possibility of connecting the indication device to the provided on board contacts 30, 31 (see 1.3. chapter).

## 4. Fresh air and exhaust air recirculation control

If air handling unit has recirculation section, additional air damper actuator FG2 (see unit electric scheme) is used for recirculation air control. Fresh air and recirculation air ratio is determined on automation box, which is installed inside the unit, at the potentiometer (in scheme RP1).

Eg. if set the potentiometer 60%, this means when unit work all times will be supplied 60% of fresh air and 40% of recirculation air, i.e. fresh air will be mixed with room (exhaust) air.



## 2.6. Troubleshooting

If the unit is inoperative:

- Make sure the feeding cable is plugged into an electrical outlet.
- Check all safety fuses of the automatic control block. In case of need, replace the faulty fuses with the new ones of the same electric parameters (fuses parameters are in wiring diagram).
- Check if the control panel does not show the "Stop" sign. In such case failure has to be eliminated. For the purpose, be guided by Table 2.6, presenting failure description.
- Should the remote control panel be blank and the display screen be not lighted, check the integrity of the cable connecting the control panel with the unit.

✓ **Note:**

If the display of the control panel is not shining and unit is not operating it can be normal unit working regime, in case if it was stopped by remote device (see chapter 2.5.)

According to the damage level, the air-handling unit may be either stopped or not. If the unit is being stopped the control panel display shows "Stop" sign (see Picture 2.6).

2.6 Picture

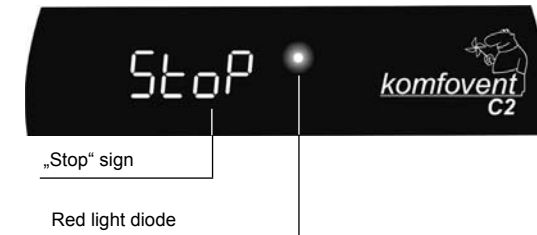

Failures Displayed on the Control Panel and Possible Fault Causes

The unit works	Red colour light diode	Indication of the control panel	Possible fault cause
Yes	Flashes (blinks) every second	The temperature is shown, the ventilation rate or automatic mode is indicated (A)	Supply air filter is clogged. It must be changed.
No	Shines	"Stop" sign is shown	Return water low temperature. Frost of heater returns water possibility.
No	Does not shine (no light)	"Stop" sign is shown	Electric heater overheating (if provided).
			Getting fire alarm from the fire-prevention system.
			Temperature sensor not connected or faulty.



The emergency protection may be restarted with the "RESET" button only following the heater overheating cause isolation and troubleshooting.



If the unit is shut down and control panel shows text message "Stop", the failure must be eliminated!



Before starting any operations inside the unit, make sure that the unit is switched off and the power supply voltage is shut off.

Having eliminated failure, unit is restarted by the button  after what it continues its operation in the previous mode. However, if failure is not eliminated, air handling unit will not be started-up, and on the control panel will be displayed "Stop" message.

# Unit Functional Diagram

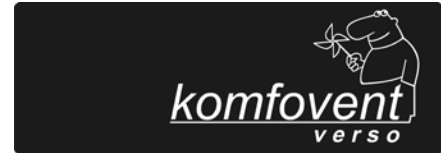

VERSO-S Functional Diagram

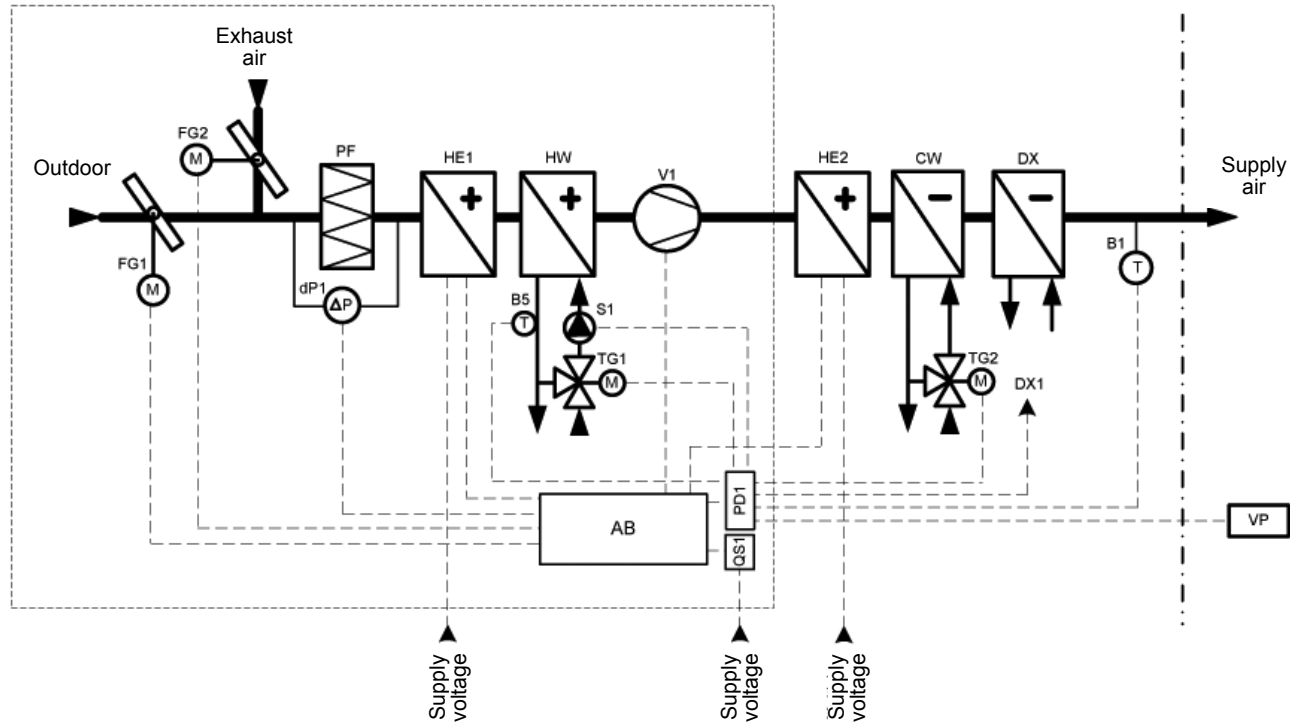

AB	Control box	HE1, HE2	Electric heater
B1	Supply air temperature sensor	HW	Water heater
B5	Return water temperature sensor	PF	Air filter
CW	Water cooler	S1	Circulation pump
DX1	DX cooling control	TG1	Hot water mixing valve actuator
dP1	Pressure switch for filter	TG2	Cold water mixing valve actuator
FG1	Supply air damper actuator	V1	Supply air fan
FG2	Air mixing damper actuator	VP	Control panel

✓ **Note:**

Position of the detailed item (bend) is indicated in the drawing of specific unit.

# Specification

Depending on the unit type, various automation system principle solutions are possible. Electrical connection of the particular unit is specified in the principal electric diagram.

Schemes marking names are described in the table on the right.

## Specification of the Components

Marking	Description
B5	Return water temperature sensor
C2-P1	External connections board
C2-VS_	Control board
DK1	Supply air fan motor frequency converter
dP1	Supply air filter differential pressure switch
E	Triacs control panel
EK1 - EK3	Electric heater steps
F_	The fuse
FG1	Fresh air damper actuator.
FG2	Recirculation air damper actuator
KM1 - KM3	Electric heater stages protection contactors
PD1	Connection box
RP1	Air mixing setpoint potentiometer
S1 - S6	Triac
SA1	"Winter / Summer" season switch
TK1	Electric heater 80°C overheating protection (automatic reset)
TK2	Electrical heater 120°C overheating protection (manual reset)
TK3	Triacs 80°C overheating protection (automatic reset)
QF1 - QF3	Automatic switch
QS1	Main switch
V1	Supply air fan
X1...X4	Connections between unit sections

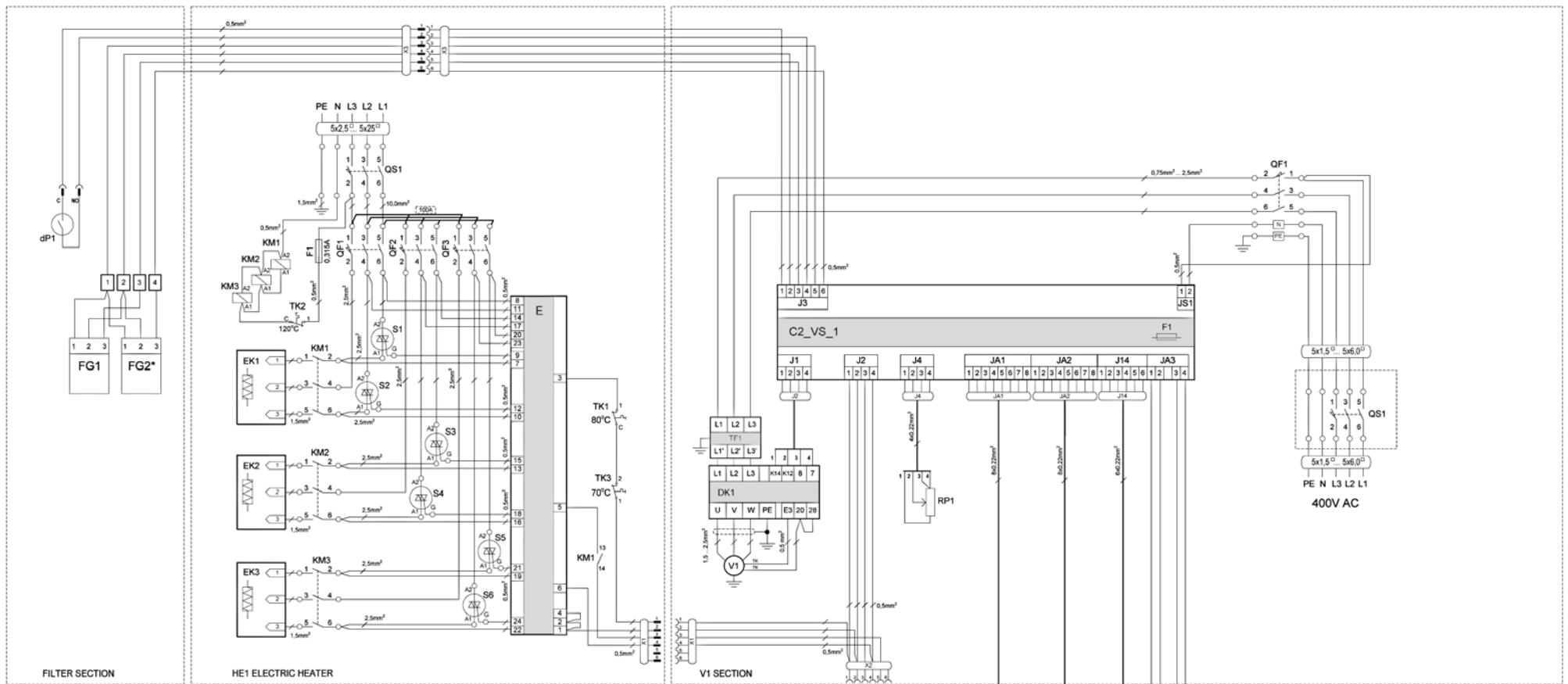

✓ **Note:**  
If provided only one heater section HE1:  
Heater connector X1 is connected to control system connector X2.

FG2\* - intended for units with air mixing section only.

**DK1 frequency inverter settings**

Code	Meaning
P 100	4
P 101	1
P 104	60.0
P 105	30.0
P 110	3
P 121	1
P 140	3
P 162	1.00
P 240	4.0
P 241	1.0

**Colors marking:**  
R - red;  
Y - yellow;  
G - green;  
W - white;  
O - orange;  
E - grey;  
B - blue;  
N - brown;  
K - black  
P - pink  
V - violet  
L - light blue

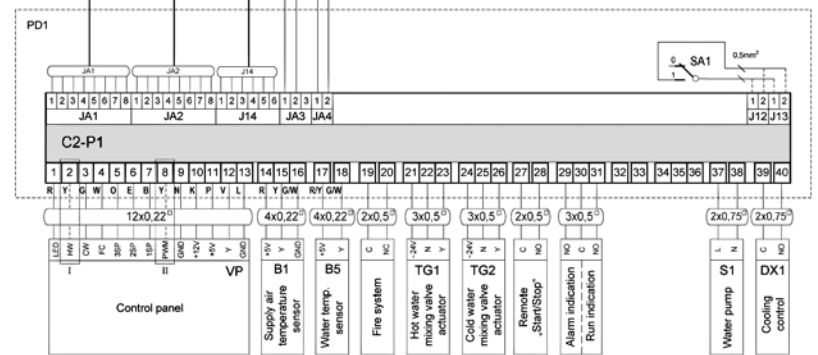
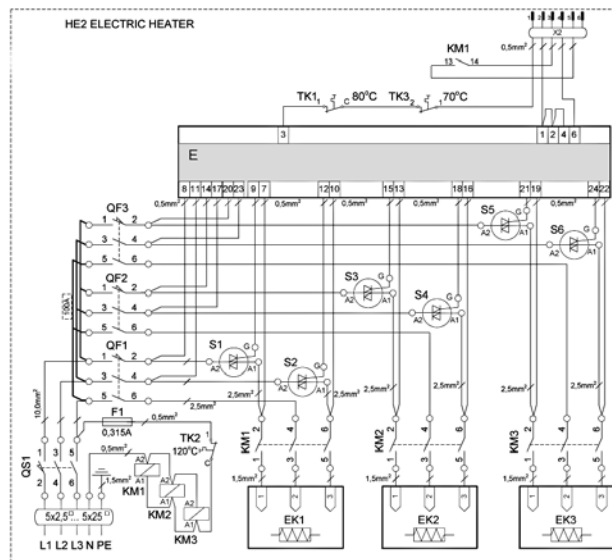

If unit is with water heater:  
Control panel connection - I  
SA1 switch connection - J13

If unit is with electric heater:  
Control panel connection - II  
SA1 switch connection - J12

Wiring diagram



**UAB AMALVA**

OZO str. 10, LT-08200 VILNIUS, LITHUANIA

e-mail [info@amalva.lt](mailto:info@amalva.lt)

[www.amalva.com](http://www.amalva.com)

[www.komfovent.com](http://www.komfovent.com)