

Variable air volume dampers

CONTENT

Description	3
Variable air volume damper	3
Size and dimensions.....	4
KOS-C damper	4
KOS-R damper.....	4
KOS-C-I damper.....	5
KOS-R-I damper	6
Installation	7
Installation information and precautions	7
Controller connections.....	8
Controller connections options.....	8
Analogue connection	8
MP-Bus connection.....	8
Modbus or BACnet connection	9
KNX connection	10
Pressure drop and sound power level	11
KOS-C pressure drop and sound power level diagrams.....	11
Pressure drop and sound power level.....	12
Pressure drop diagram example	13
KOS-R pressure drop and sound power level.....	14
Correction values.....	15
Correction values for other case widths.....	15
Control systems.....	16
VAV dampers with Bus connection	16
Actuator Adjustment Tools	17
Order information	18

Description

Variable air volume damper

- Air volume regulation damper.
- Suitable for the control of air volume flow rate, room pressure or duct pressure.
- Available circular dimensions: Ø100-560 mm.
- Available rectangular dimensions: 200×100 to 1000×1000 mm. Size step: 100 mm.
- Effective flow measurement design to ensure highest precision of readings.
- Air flow speed measurement up to 0.5 m/sec.
- Closed blade air leakage class 4 according to EN 1751.
- Casing air leakage class D according to EN 1751.
- Suitable for installation in places with limited straight duct section availability before the damper.
- In-factory presetting of the controllers.
- Can be supplied with actuators that have analogue, MP-bus, Modbus, BACnet and KNX communication.
- Simple adjustment of settings with ZTH or PC tool.
- An insulated model is available for sound attenuation through the case.



Circular air volume regulation damper KOS-C

KOS-C and KOS-R is an air flow regulator for variable air volume (VAV) regulation in duct systems. Damper consists of blade, measuring unit and controller. Damper is fitted with a differential pressure sensors for measuring the volume flow rate. The flow regulation can be controlled from room controller or BMS system.

The KOS-C VAV damper from KOMFOVENT has a unique solution. The measuring pressure tubes inside of the damper are of unique shape that provides the best results and accurate flow measurement also on a lower air flow speeds according to the study and research made. For circular VAV dampers KOS-C, at air velocity from 10 m/sec to 1 m/sec measurement deviation is 5%. At air velocity from 1 m/sec to 0.5 m/sec measurement deviation is 9%.

Rectangular VAV dampers air velocity range starts from 0.8 m/sec with deviation 10%. Circular VAV dampers air velocity range starts from 0.5 m/sec with deviation 9%.



Rectangular air volume regulation damper KOS-R

It's one of the best air velocity measurement precisions in HVAC industry.

The damper controller can provide the variable air flow mode where the air flow is regulated in between the values V_{min} and V_{max} . Also the damper controller can provide mode where air flow is kept constant using parameters V_{min} , V_{max} , Open or Closed. The damper can work as a room or duct pressure regulator where volumetric flows are regulated in a range between V_{min} and V_{max} depending on the function of supply air which can be controlled with room or other controller.

The setpoints for V_{min} and V_{max} are preset in factory but can also be readjusted afterwards. Easy adjustments of VAV damper operating values can be made with ZTH service tool and adjustment tool app.

Appropriate air filters must be installed where high air dust pollution is possible as the contamination can negatively impact measurement accuracy.

Size and dimensions

KOS-C damper is available in 10 different sizes

KOS-C damper

Circular dampers KOS-C available in 10 dimensions: Ø100-560 mm

Size and dimensions			V, m ³ /h	
D	L	A, mm	min	max
100	390	45	15	283
125	390	45	22	442
160	390	45	36	724
200	390	45	57	1131
250	592	45	88	1767
315	592	45	140	2806
355	600	45	482	4275
400	600	45	615	6047
500	750	45	973	9484
560	791	45	1155	11550

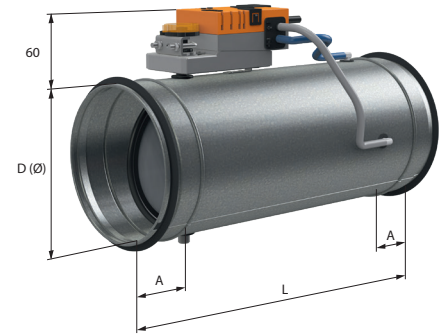

KOS-R damper

Available dimensions of rectangular dampers KOS-R :

from 200×100 to 1000×1000 mm, when the size of the “step” is 100 mm

Size and dimensions		V, m ³ /h	
B	H	min	max
200	100	58	720
300		86	1080
400		115	1440
200		115	1440
300	200	173	2160
400		230	2880
500		288	3600
600		346	4320
300	300	259	3240
400		346	4320
500		432	5400
600		518	6480
700	300	756	7560
800		864	8640
900		1264	9720
1000		1404	10800

Size and dimensions		V, m ³ /h	
B	H	min	max
400	400	461	5760
500		576	7200
600		864	8640
700		1310	10080
800	500	1728	11520
900		1944	12960
1000		2160	14400
500		900	9000
600	500	1404	10800
700		1890	12600
800		2160	14400
900		2430	16200
1000	600	2700	18000
600		1685	12960
700		2268	15120
800		2592	17280
900	600	2916	19440
1000		3240	21600

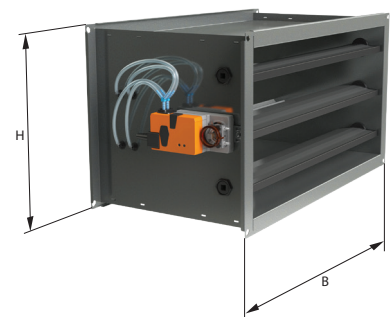

Size and dimensions		V, m ³ /h	
B	H	min	max
700	700	2646	17640
800		3024	20160
900		3402	22680
1000	800	3780	25200
800		3456	23040
900		3888	25920
1000	900	4320	28800
900		4374	29160
1000		4860	32400
1000	1000	5400	36000

Size and dimensions

KOS-C-I damper

An insulated damper version KOS-C-I is available to reduce the possible radiated noise through the case.

The insulation is made from 50 mm thick mineral wool ISOVER KT-40 that is covered with a metal sheet made from zinc coated galvanized steel. ISOVER KT-40 fire resistance is classified as A1 in accordance with EN 13501.



Size and dimensions				V, m³/h	
d	D	L	L ₁	min	max
100	199	390	312	15	283
125	224	390	312	22	442
160	259	390	312	36	724
200	299	390	312	57	1131
250	349	592	514	88	1767
315	414	592	514	140	2806
355	453	600	530	482	4275
400	498	600	530	615	6047
500	598	750	680	973	9484
560	658	791	721	1155	11550

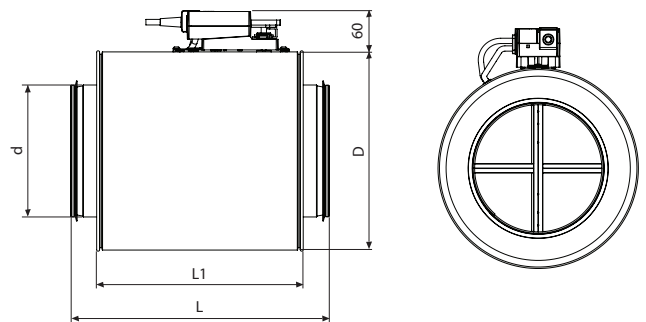

There is an option to order the insulated version with outer casing made from stainless steel.

KOS-C-I has the following sound insulating capacity R, dBA for required frequency:

Frequency, Hz	63	125	250	500	1000	2000	4000	8000
R _v , dBA	7	7	14	21	25	28	28	25

Size and dimensions

KOS-R-I damper

Size and dimensions		V, m ³ /h	
B	H	min	max
200	100	58	720
300		86	1080
400		115	1440
200	200	115	1440
300		173	2160
400		230	2880
500		288	3600
600		346	4320
300		259	3240
400	300	346	4320
500		432	5400
600		518	6480
700		756	7560
800		864	8640
900		1264	9720
1000	400	1404	10800
400		461	5760
500		576	7200
600		864	8640
700		1310	10080
800		1728	11520
900	500	1944	12960
1000		2160	14400
500		900	9000
600		1404	10800
700		1890	12600
800		2160	14400
900	1000	2430	16200
1000		2700	18000

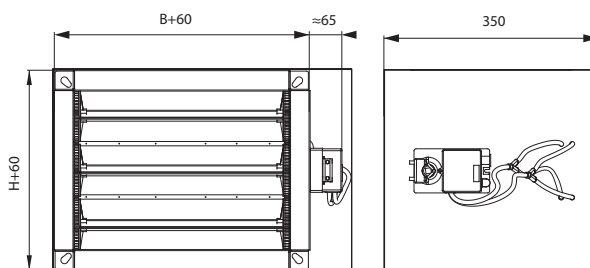

Size and dimensions		V, m ³ /h	
B	H	min	max
600	600	1685	12960
700		2268	15120
800		2592	17280
900		2916	19440
1000		3240	21600
700	700	2646	17640
800		3024	20160
900		3402	22680
1000	800	3780	25200
800		3456	23040
900		3888	25920
1000	900	4320	28800
900		4374	29160
1000		4860	32400
1000	1000	5400	36000

KOS-R-I has the following sound insulating capacity R_i, dBA for required frequency:

Frequency, Hz	63	125	250	500	1000	2000	4000	8000
R _i , dBA	7	7	14	21	25	28	28	25

Installation

Installation information and precautions

Precautions must be taken into consideration where dampers are installed in places where extreme temperature conditions can be met and condensation can build up inside the duct and thus inside of damper. The condensation and also the large temperature difference between inside and outside air can affect measurement results in a negative way.

To avoid flow measurement deviation and unnecessary errors, the minimum distance before the VAV damper must be observed (see drawings below).

Straight section of duct equal to $2 \times D$ (for circular ducts) or $2 \times B$ (for rectangular ducts) from 90° bend or T-piece is the minimum requirement when installing dampers.

Using smaller straight section will lead to a bigger flow measurement error. A bigger straight distance is recommended after silencers, fire dampers and other ventilation duct system components.

To achieve the best sound power level, dampers should be connected to the duct with rivets and not the screws. This recommendation also refers to the entire duct system.

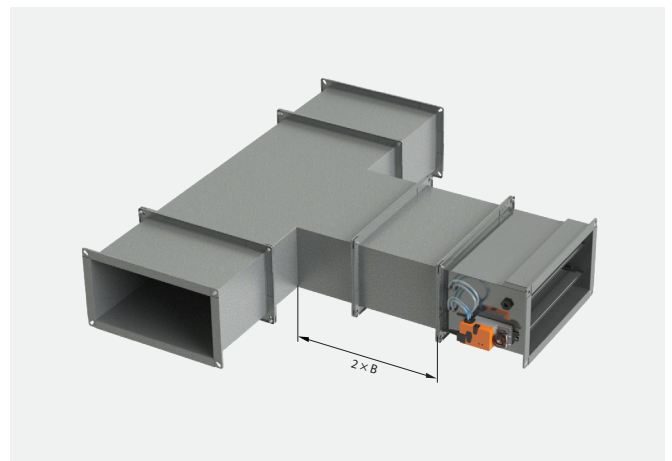
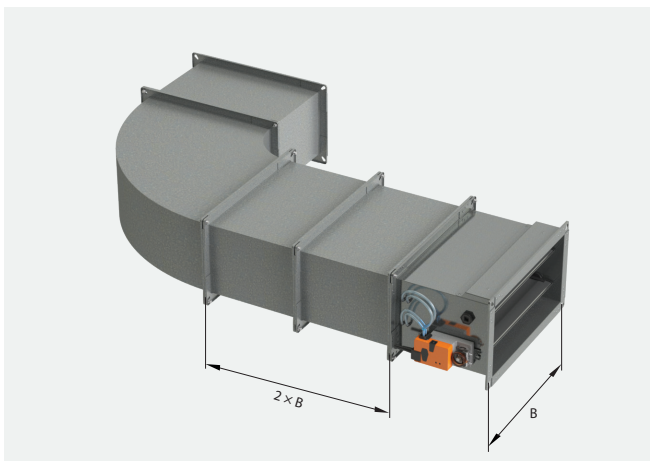
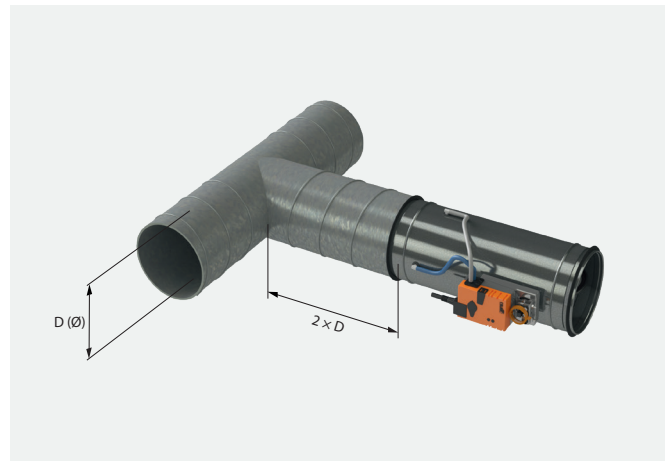

Controller connections

Controller connections options

4 controller options are available for KOS damper:

- analogue connection
- MP-bus communication
- Modbus or BACnet communication
- KNX communication

Analogue connection

With analogue connection it is possible to connect controller 0...10 V or 2...10 V to the VAV damper and control the air volume, depending on the given signal and set up.

MP-Bus connection

The MP-Bus is master/slave bus technology where defined number of slaves can be connected to a MP-Master unit. Below is a connection scheme for MP-bus type actuators.

Type	Torque	Power consumption	Rating	Weight
LMV-D3-MF-F	5 Nm	2 W	3.5 VA (max. 8 A @ 5 ms)	Approx. 500 g

VAV – variable operation $V_{min} \dots V_{max}$

Wiring diagrams

Example 1:
VAV, analogue reference signal

Example 2:
VAV with shut-off (CLOSED), 2... 10V mode

Description:
Damper CLOSED via 0 ... 10 V reference signal (Mode 2 ... 10 V)
Setting parameters:
Mode 2 ... 10 V, Shut off level 0.1 V or 0.5 V
If the required switching threshold of 0.1 V cannot be attained, the value can be switched to 0.5 V with PC-Tool.
Function: Standard 0.1 V: Shut-off level 0.5 V:
Damper CLOSED <0.1 V <0.5 V
>0.1 ... 2 V >0.5 V ... 2 V
 \dot{V}_{min} ... \dot{V}_{max} 2 ... 10 V 2 ... 10 V
In CAV applications shut-off level must not be set to 0.5 V, otherwise the open connection 3 is interpreted as damper CLOSED.

© BELIMO Automation AG

* ZTH-U; MP gateway

Controller connections

Modbus or BACnet connection

The Modbus protocol is used to establish master-slave / client-server communication between intelligent devices.

Using Modbus, a master (e.g. automation station) and several slaves can be interconnected. Below is a connection scheme for Modbus type actuators.

Type	Torque	Power consumption	Rating	Weight
LMV-D3-MOD	5 Nm	2 W	3.5 VA (max. 8 A @ 5 ms)	Approx. 500 g

Electrical installation

BACnet MS/TP / Modbus RTU

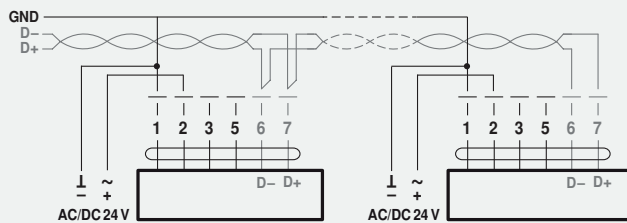

Cable colours:

- 1 = black
- 2 = red
- 3 = white
- 5 = orange
- 6 = pink
- 7 = gray

Signal assignment Modbus:

- C₁ = D- = A
- C₂ = D+ = B

Connection with switching contact, e.g. Δp-monitor

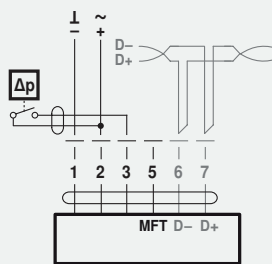

Switching contact requirements:
The switching contact must be able to switch a current of 16 mA at 24V accurately.

Connection of active sensors, e.g. 0...10 V @ 0...50 °C

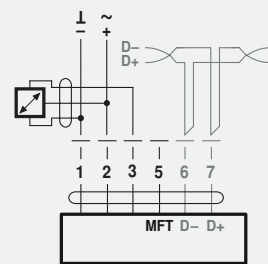

Possible voltage range:
0 ... 32 V (resolution 30 mV)

BACnet MS/TP / Modbus RTU with analog setpoint (hybrid mode)

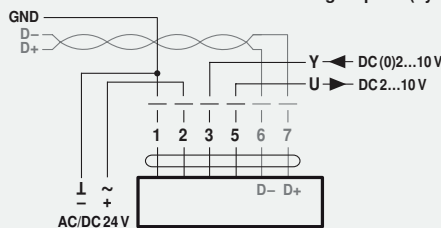

Operating on the MP-Bus

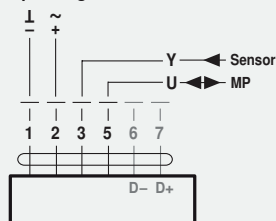

Controller connections

KNX connection

KNX devices are generally connected by a twisted pair bus and can be modified from a controller. Below is a connection scheme for KNX type actuators.

Type	Torque	Power consumption	Rating	Weight
LMV-D3-KNX	5 Nm	2 W	4 VA (max. 8 A @ 5 ms)	Approx. 500 g

Electrical installation

Connection without sensor

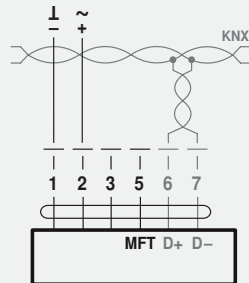

KNX signal assignment:
 D+ = KNX+ (pink > red)
 D- = KNX- (grey > black)
 The connection to the KNX line should take place via WAGO connection terminals 222/221.

Connection with switching contact, e.g. Δp -monitor

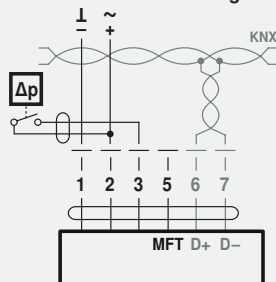

Switching contact requirements:
 The switching contact must be able to switch a current of 16 mA at 24V accurately.

Connection of active sensors, e.g. 0...10 V @ 0...50°C

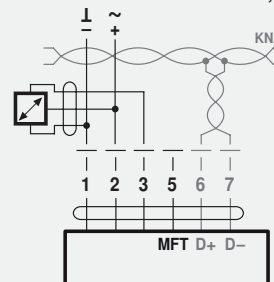

Possible voltage range:
 0 ... 32 V (resolution 30 mV)

Local override control

If no sensor is integrated, then connection 3 (Y) is available for the protective circuit of a local override control.

Options: CLOSED – \dot{V}_{max} – OPEN

Note: Functions only with AC 24V supply!

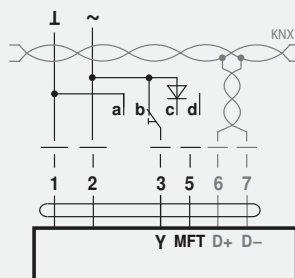

a Damper CLOSED
 b \dot{V}_{Max}
 c Damper OPEN
 d Bus mode

Pressure drop and sound power level

KOS-C pressure drop and sound power level diagrams

The diagrams provide an A-weighted sound power levels that KOS-C damper emits in duct, L_{wa} . Correction factors K are provided to find emitted sound power level at the conformable frequency. Emitted sound L_w should be calculated as: $L_w = L_{wa} + K$.

Example: for KOS-C-125 damper with airflow $Q = 90 \text{ m}^3/\text{h}$ and project pressure drop $\Delta P = 60 \text{ Pa}$, A-weighted sound power level is calculated as 42 dB(A).

To find emitted sound power level at 250 Hz, correction factor given in Table 1 should be used for Ø125, so $L_w = 42 + 3 = 45 \text{ dB(A)}$.

Diagram 1: Ø100 A – weighted sound power level L_{wa} , dB

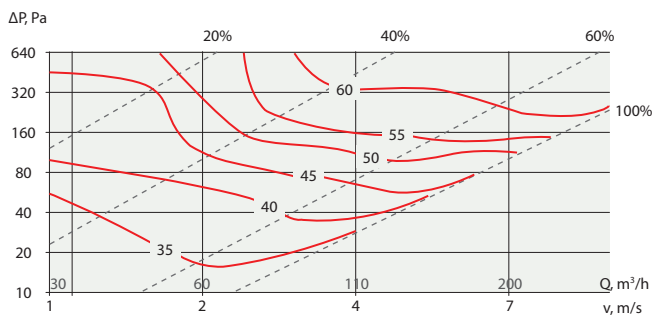

Diagram 2: Ø125 A – weighted sound power level L_{wa} , dB

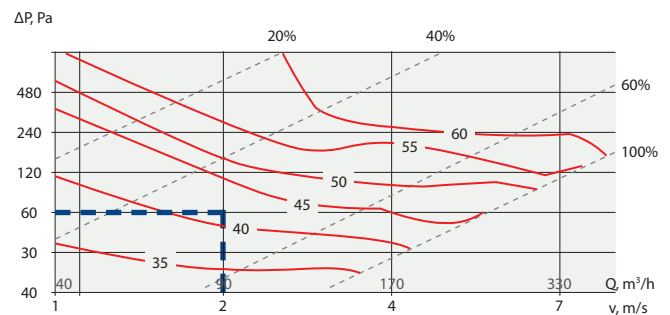

Diagram 3: Ø160 A – weighted sound power level L_{wa} , dB

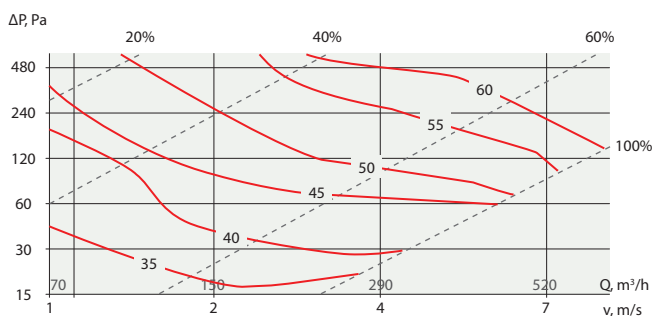

Diagram 4: Ø200 A – weighted sound power level L_{wa} , dB

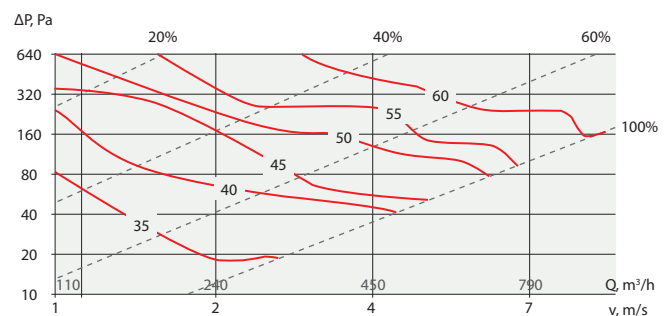

Diagram 5: Ø250 A – weighted sound power level L_{wa} , dB

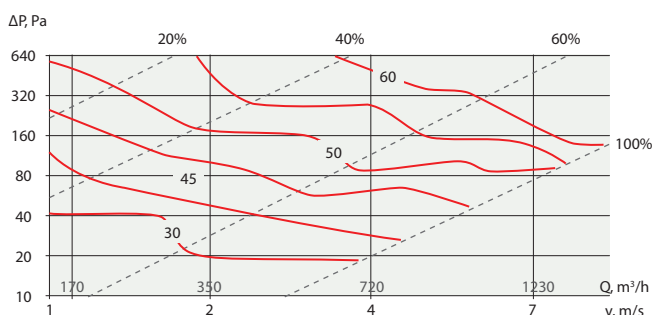
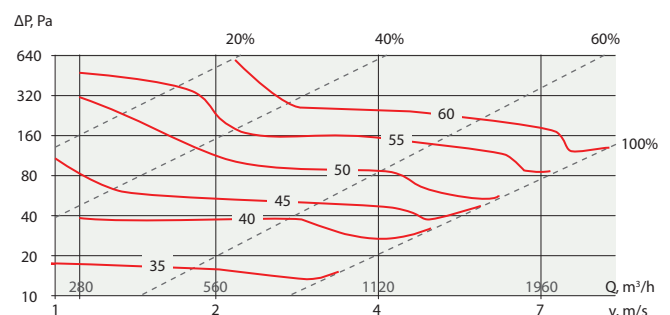

Diagram 6: Ø315 A – weighted sound power level L_{wa} , dB



Pressure drop and sound power level

Diagram 7: Ø355 A – weighted sound power level L_{wa} , dB

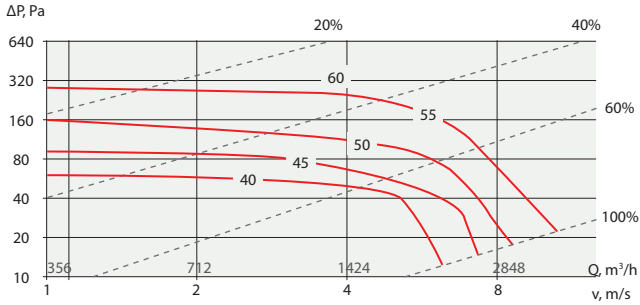

Diagram 8: Ø400 A – weighted sound power level L_{wa} , dB

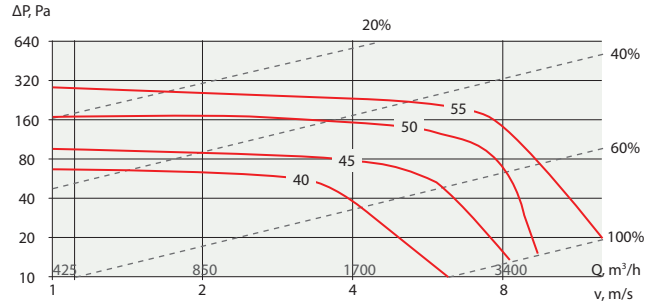

Diagram 9: Ø500 A – weighted sound power level L_{wa} , dB

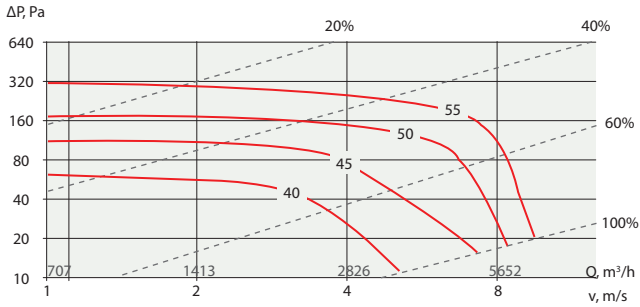

Diagram 10: Ø560 A – weighted sound power level L_{wa} , dB

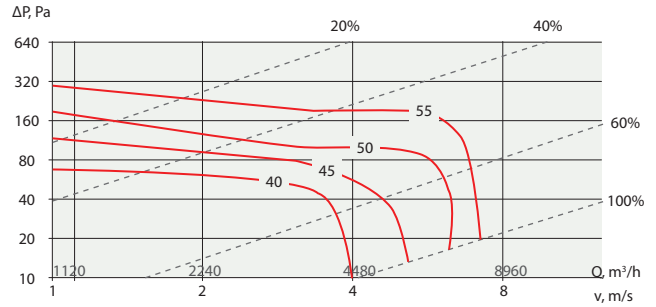

Table 1: Correction factors to find emitted sound power level for required frequency, $K=f(v, \varnothing)$, dB:

Ø	K, dB						
	63	125	250	500	1000	4000	8000
100	9	13	5	0	-3	-6	-7
125	13	5	3	-3	-7	-15	-20
160	10	6	0	-5	-9	-17	-22
200	9	5	-1	-6	-10	-19	-24
250	8	3	-3	-7	-10	-20	-26
315	6	1	-4	-8	-12	-22	-28
355	8	2	-2	-4	-9	-17	-18
400	11	6	1	-2	-7	-19	-20
500	10	5	-1	-2	-6	-18	-17
560	10	3	1	-3	-6	-13	-14

Pressure drop and sound power level

Pressure drop diagram example

Pressure drop diagram indicates total pressure drop over the KOS-C damper as a function of air flow Q and the blade angle (100% as totally open blade).

Example: for KOS-C 200 damper with airflow $Q = 240 \text{ m}^3/\text{h}$ and blade position 60%, total pressure drop $\Delta P = 40 \text{ Pa}$ (see picture below).

Diagram 4: Ø200 A – weighted sound power level L_{wa} , dB

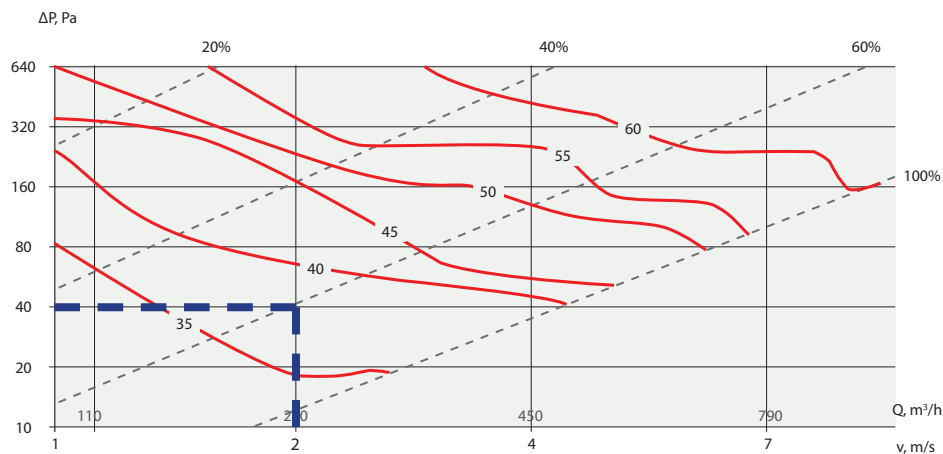

Pressure drop on open VAV damper

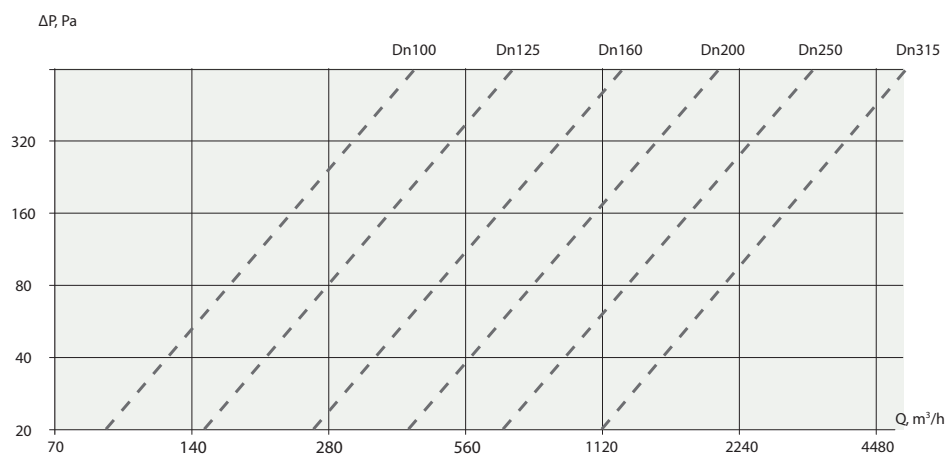

KOS-R pressure drop and sound power level

P_s [Pa]	f_{sr} [Hz]	Size B × H [mm]																			
		600																			
		100				200				300				400				500			
		v [m/s]																			
L_w [dB/Okt]																					
125	63	45	55	63	68	51	60	68	73	53	63	71	76	56	65	73	78	59	68	76	81
	125	46	56	63	68	49	58	66	71	51	60	68	73	52	61	69	74	53	63	71	75
	250	42	49	54	57	46	53	58	61	48	55	60	63	50	56	62	64	52	59	64	67
	500	44	47	50	52	45	48	51	53	45	49	51	53	46	49	52	53	46	50	52	54
	1000	46	49	51	53	48	50	53	54	48	51	53	55	49	52	54	55	50	52	55	56
	2000	46	49	51	53	49	52	54	56	51	54	56	58	52	55	57	59	54	57	59	60
	4000	39	43	47	49	41	46	50	52	43	47	51	53	44	49	52	55	45	50	54	56
8000	32	37	41	43	36	41	45	47	38	43	47	50	40	45	49	51	42	47	51	54	
250	63	52	61	68	72	56	64	71	75	58	66	73	77	59	68	75	79	61	70	77	81
	125	49	58	65	70	53	61	69	73	55	64	71	75	56	65	72	77	58	67	74	79
	250	46	53	58	62	49	56	62	66	51	58	64	68	53	60	66	69	55	62	68	72
	500	48	52	56	58	50	54	58	60	51	55	59	61	51	56	59	62	52	57	61	63
	1000	51	54	57	59	52	56	59	61	53	57	60	61	54	57	60	62	55	58	61	63
	2000	53	56	58	59	56	58	61	62	57	60	62	64	58	61	63	65	60	63	65	66
	4000	49	52	55	57	51	54	57	59	52	56	59	60	53	56	59	61	54	58	61	63
8000	45	49	52	54	47	51	54	56	49	53	56	58	50	64	57	59	51	55	58	60	
500	63	57	65	72	76	60	69	76	80	63	71	78	82	64	73	80	84	67	75	82	86
	125	53	63	71	77	56	66	74	80	58	68	76	81	59	69	77	83	61	71	79	84
	250	49	58	66	70	55	64	72	76	59	68	75	80	61	70	78	82	54	74	81	86
	500	53	59	63	66	56	62	66	69	58	63	68	71	59	65	69	72	61	66	71	73
	1000	59	62	64	66	61	64	66	67	62	64	67	68	62	65	68	69	63	66	69	70
	2000	64	65	66	66	66	67	68	69	68	69	70	70	69	70	71	71	70	71	72	73
	4000	63	64	65	66	65	66	67	68	66	67	68	69	67	68	69	69	68	69	70	70
8000	59	61	63	64	61	63	65	66	62	65	66	68	63	65	67	69	64	67	69	70	

P_s [Pa]	f_{sr} [Hz]	Size B × H [mm]																								
		600										1000														
		600					700					800					900					1000				
		v [m/s]																								
L_w [dB/Okt]																										
125	63	59	68	76	81	62	71	79	84	64	74	82	87	65	75	83	88	66	76	83	88					
	125	53	63	71	75	55	65	73	77	57	66	74	79	57	67	75	80	57	67	75	80					
	250	52	59	64	67	54	61	66	69	56	63	68	71	57	64	69	72	58	64	69	73					
	500	46	50	52	54	47	51	53	55	47	51	53	55	48	51	54	55	48	51	54	55					
	1000	50	52	55	56	51	53	56	57	51	54	56	57	51	54	56	58	51	54	56	58					
	2000	54	57	59	60	56	59	61	62	57	60	62	64	58	61	63	65	58	61	63	65					
	4000	45	50	54	56	47	52	56	58	49	53	57	59	49	54	58	60	49	54	58	60					
8000	42	47	51	54	45	50	54	56	47	52	56	58	48	53	57	59	48	53	57	59						
250	63	61	70	77	81	63	72	79	83	65	74	80	85	66	75	81	86	66	75	82	86					
	125	58	67	74	79	60	69	77	81	62	71	79	83	63	72	80	84	64	72	80	84					
	250	55	62	68	72	57	65	70	74	59	67	72	76	60	68	73	77	61	68	73	77					
	500	52	57	61	63	54	58	62	64	55	59	63	65	55	60	63	66	55	60	63	66					
	1000	55	58	61	63	56	59	62	64	57	60	63	65	57	61	64	65	57	61	64	65					
	2000	60	63	65	66	62	65	67	68	63	66	68	69	64	67	69	70	64	67	69	70					
	4000	54	58	61	63	56	59	62	64	57	60	63	65	57	61	64	66	57	61	64	66					
8000	51	55	58	60	53	57	60	62	54	58	61	63	55	59	62	64	55	59	62	64						
500	63	67	75	82	86	69	78	85	89	71	80	87	91	72	81	88	92	72	81	88	92					
	125	61	71	79	84	63	73	81	86	64	74	83	88	65	75	84	89	65	75	84	89					
	250	65	74	81	86	69	78	85	90	72	81	88	93	73	82	89	94	74	83	90	95					
	500	61	66	71	73	63	68	73	75	64	70	74	77	65	71	75	78	65	71	75	78					
	1000	63	66	69	70	64	67	70	71	65	68	70	72	66	69	71	72	66	69	71	72					
	2000	70	71	72	73	72	73	74	75	73	75	75	76	74	75	76	77	74	75	76	77					
	4000	68	69	70	70	69	70	71	72	70	71	72	73	70	72	73	73	70	72	73	73					
8000	64	67	69	70	66	68	70	71	67	69	71	72	68	70	72	73	68	70	72	73						

Correction values

Correction values for other case widths

Δp_s [Pa]	f_{sr} [Hz]	In relation to B [mm]											
		600									1000		
		200	300	400	500	600	700	800	900	1000	800	900	1000
125	63	-8	-5	-3	-1	0	1	2	3	4	-2	-1	0
	125	-4	-3	-2	-1	0	1	1	2	2	-1	-1	0
	250	-6	-4	-2	-1	0	1	2	2	3	0	0	0
	500	-2	-1	-1	0	0	0	0	1	1	-1	-1	0
	1000	-2	-1	-1	0	0	0	1	1	1	-1	0	0
	2000	-5	-3	-2	-1	0	1	1	2	2	-1	0	0
	4000	-4	-3	-2	-1	0	1	1	2	2	-1	-1	0
	8000	-6	-4	-2	-1	0	1	2	2	3	0	-1	0
250	63	-5	-3	-2	-1	0	1	1	2	3	-1	-1	0
	125	-6	-4	-2	-1	0	1	1	2	3	-1	-1	0
	250	-6	-4	-2	-1	0	1	2	2	1	-1	-1	0
	500	-3	-2	-1	0	0	0	1	1	1	-1	0	0
	1000	-3	-2	-1	0	0	0	1	1	2	-1	0	0
	2000	-4	-3	-2	-1	0	1	1	2	2	-1	0	0
	4000	-3	-2	-1	-1	0	0	1	1	2	-1	0	0
	8000	-4	-3	-1	-1	0	1	1	1	3	-1	0	0
500	63	-6	-4	-2	-1	0	1	2	2	2	-1	-1	0
	125	-5	-3	-2	-1	0	1	1	2	4	-1	-1	0
	250	-10	-6	-4	-2	0	1	3	4	2	-1	0	0
	500	-5	-3	-2	-1	0	1	1	2	1	-2	-1	0
	1000	-3	-2	-1	0	0	1	1	1	2	-1	0	0
	2000	-4	-3	-2	-1	0	1	1	2	1	-1	0	0
	4000	-3	-2	-1	0	0	0	1	1	2	-1	0	0
	8000	-3	-2	-1	-1	0	0	1	1	2	-1	0	0

Control systems

VAV dampers with Bus connection

Intelligent simplicity

- System connection to DDC controller with MP interface via MP-Bus®
- Integration in higher-level systems such as LONWORKS®, Konnex, Ethernet TCP/IP, Profibus DP, Modbus RTU etc. via MP gateway
- Convenient, cost-efficient wiring
- Maximum flexibility in new, retrofitted, converted or renovated buildings

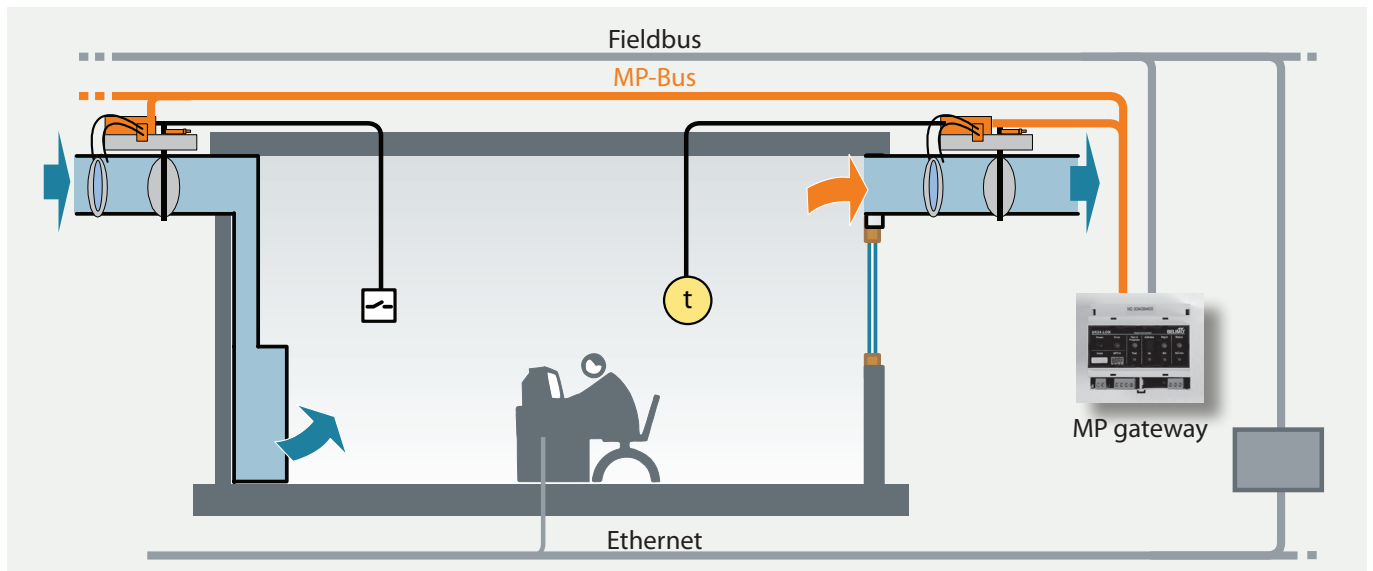

MP-BUS®



KNX®



Modbus-RTU

ASHRAE BACnet®

© BELIMO Automation AG

Control systems

Actuator Adjustment Tools

ZTH service tool

The ZTH directly connects to the Belimo Multi-Function Technology (MFT) series actuator offering the ability to quickly change the parameters of the actuator, such as control input, control feedback, runtime, and minimum and maximum values.



Belimo Assistant app

Belimo Assistant app allows you to check and control your actuator using your smartphone. No ZTH tool needed! Simple, wireless connection via integrated NFC interface. App displays device-specific identification data: device type, position, designation, serial number, MP address. Even when actuator is deenergized data can be read and written.



It is also possible to store operating/setting data on the smartphone or send data directly from system via e-mail, WhatsApp or SMS.

For using hold smartphone close to Belimo actuator. The NFC- antenna of the phone, respectively the converter's eye must be placed right over the actuator's NFC-logo. After connection is succeed application will display settings automatically.

Additional information can be obtained from www.belimo.com

Order information

Circular VAV air damper order sample:

KOS-C-I-N-160-BMF-0-100-300

① ② ③ ④ ⑤ ⑥ ⑦ ⑧

① KOS – damper type

② C – circular
R – rectangular

③ No entry – without insulation
I – with insulation 50 mm

④ No entry – zinc coated casing
N – stainless steel casing

⑤ Size – 100 / 125 / 160 / 200 / 250 / 315 / 355 / 400 / 500 / 630

⑥ Actuator type:

BMF – analogue connection
BMP – MP-bus communication
BMD – Modbus communication
BMDbn – BACnet communication
BKX – KNX communication

⑦ Control signal:

0 - 0..10 V
2 - 2..10 V

⑧ V_{\min} - V_{\max} – defined air flow, m³/h

Rectangular VAV air damper order sample:

KOS-R-I-N-400×300-BMF-0-755-2592

① ② ③ ④ ⑤ ⑥ ⑦ ⑧

① KOS – damper type

② C – circular
R – rectangular

③ No entry – without insulation
I – with insulation 50 mm

④ No entry – zinc coated casing
N – stainless steel casing

⑤ Size – 200×100 ... 1000×1000 mm

⑥ Actuator type:

BMF – analogue connection
BMP – MP-bus communication
BMD – Modbus communication
BMDbn – BACnet communication
BKX – KNX communication

⑦ Control signal:

0 - 0..10 V
2 - 2..10 V

⑧ V_{\min} - V_{\max} – defined air flow, m³/h



www.komfovent.com

SIA KOMFOVENT

Bukaišu iela 1, LV-1004 Rīga, Latvija
Tel. +371 24 66 4433
info.lv@komfovent.com



Buitendijks 63, 3356 LX Papendrecht
Tel: +31(0)85-782 64 00
Email: info@vortvent.nl