

Traditional Standard Range® Roof Models



Features & Benefits

- Extract model in 4 sizes: Size 6, 7, 9 and 12.
- IPX4 Rated.
- Colour: White.
- Wide range of sensors available.
- Manufactured in weather-resistant polymeric materials.
- For the best performance from your fan, use an Ecotronic controller.

Classic Retro-Styled Ventilation

A versatile and robust range of roof extract ventilating units designed to satisfy the requirements of efficient ventilation in commercial and industrial applications. The simple, proven design of Standard Range makes installation and routine cleaning easy.

Featuring a low profile cowl, the unit is ready for fitting into horizontal, angled and vertical glass, fixing plates on roofs and in vertical windows or walls in exposed areas. With Vent-Axia roof plate assemblies, all four sizes can be fitted easily into flat roofs. Suitable for roof installation plus window and wall installation

in exposed areas (eg: coastal positions). Vent-Axia's spigot and ring method of fixing ensures easy installation and weather proof joint. We recommend the use of sealing compound under the upper part of the unit when fitted in roofs.

Motor

Purpose designed enclosed motor. Suitable for running at any angle. Quiet running, continuous rated motor with sealed for life ball bearings.

Suitable for operation in ambient temperatures from -40°C to +50°C. Fitted with Standard Thermal Overload Protection. (S.T.O.P.) Supply voltage 220-240V/1/50Hz.

All Standard Range roof models are designed to fit directly into horizontal and sloping windows including wired cast, up to 10mm thick.

In solid roofs, install using a roof plate assembly and, if required, and eggcrate grille in the ceiling below. A suitable sealing compound should be used between the glass/roof plate and the exterior seal.

Models

Size	Stock Ref
S6RF	131410B
S7RF	132410B
S9RF	133410B
S12RF	134410B

Dimensions (mm)

Size	6 mm	7 mm	9 mm	12 mm
A	140	147	166	201
B Ø	216	254	295	381
C	21	21	21	21
D	95	108	121	146
E Ø	267	330	394	508
Fixing hole Ø	184	222	260	337
Weight kg	3.2	3.9	5.5	8.5

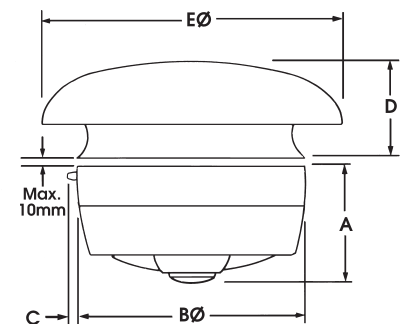

Performance

Model	Extract Performance m³/h (l/s) F.I.D.	Watts MAX.	Sound dB(A) @ 3m	Amps @ 240V
S6RF	240 (67)	32	36	0.16
S7RF	350 (97)	34	31	0.16
S9RF	625 (174)	53	39	0.24
S12RF	1130 (314)	84	42	0.36

For further performance details please go to www.vent-axia.com