

STANDARD WINDOW SPARES

Vent-Axia

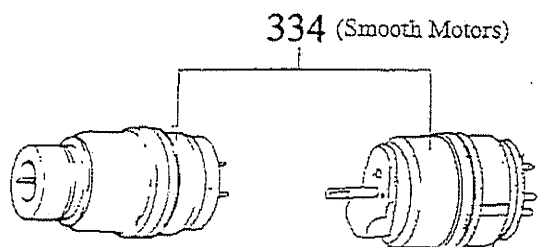
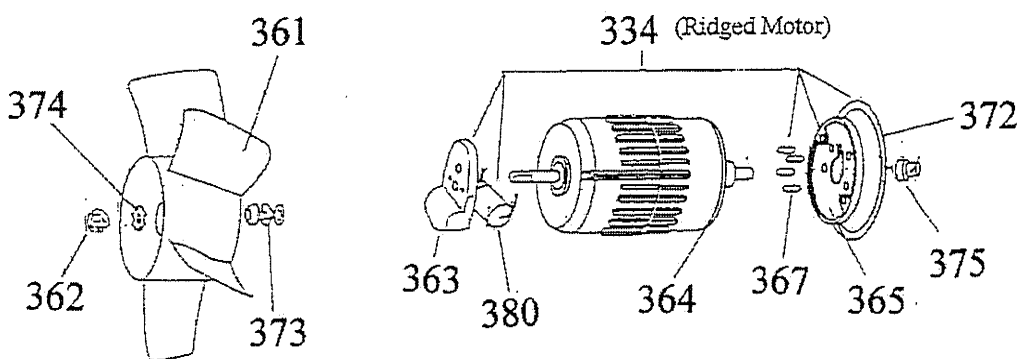
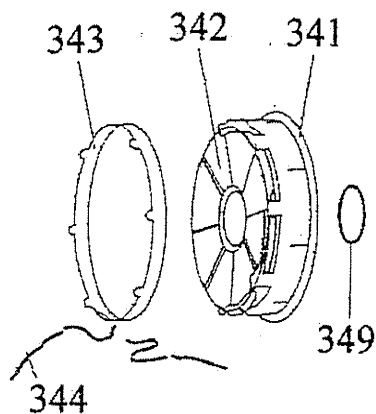
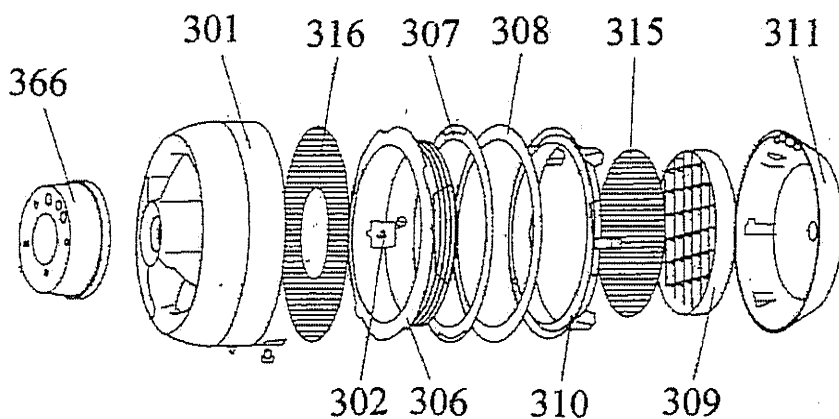

PLEASE NOTE:

These smooth motors have been replaced with the above ridged motor

STANDARD - WINDOW SPARE PARTS LIST



Vent-Axia

Diag	DESCRIPTION	SIZE 6	SIZE 7	SIZE 9	SIZE 12
301	Housing incl.locking bolt,retainers, sleeves and blanks (ivory)	430031	430032	430033	430034
	Housing incl.locking bolt,retainers, &Sleeves (acid/steam resistant)	430039	430040	430041	430042
302	Retainer, sleeve and blank set	430047	430048	430049	430050
	Retainer,Sleeve (acid/steam resistant) set	430051	430052	430053	430054
306	Shroud (Ivory)	430075	430076	430077	430078
307	Gasket	430079	430080	430081	430082
308	Seal	430014	430015	430016	430017
309	Grille (Ivory)	430087	430088	430089	430090
310	Ring (Ivory)	430095	430096	430097	430098
311	Hood & Catches (with screws)	430103	430104	430105	430106
	Hood & Catches (acid/steam resistant)	430162	430163	430164	430165
315	Protective Grille - External **	563406	563407	563409	563412
316	Protective Grille - Internal **	563106	563107	563109	563112
334	Motor 220-240v (c/w nuts & seating ring)	430274	430274	430275	430276
	Motor Steam Acid 240v	430298	430298	430299	430300
341	Frame Assembly (without flaps) (Ivory)	430146	430147	430148	430149
342	Flap Plain	430629	430630		
	Flap with Red & Blue weight	430632			
	Flap with Red weight		430635	430638	430641
	Flap with Blue weight		430634	430639	430640
	Flap with Green weight	430631	430633	430637	430642
	Flap with Yellow weight			430636	
343	Cam Ring	430158	430159	430160	430161
344	Cord and Knob set	430166	430166	430166	430166
349	Buffer Ring	430339	430339	430340	430341
361	Impeller with 'D' washer	430763	430764	430765	430766
362	Cone/Impeller Nut	430334	430334	430334	430334
	Cone/Motor Nut acid/steam resistant	430364	430364	430364	430364
363	Capacitor Cover c/w screws (smooth mtr)	430213	430213	obsolete	obsolete
	Capacitor Cover c/w screws (ridged mtr)	430899	430899	430900	430901
364	Terminal Block (3-stud)	430356	430356	430356	430356
365	Terminal Block Cover (with screws)	430217	430217	430217	430217
366	Connector Socket (WW,RF & Acid Steam)	430962	430962	430962	430962
367	Motor Connector Pins(set of 3 live,1 earth)	430222	430222	430222	430222
372	Motor Seating Ring (for smooth motor)	430336	430336	430336	430338
	Motor Seating Ring (for ridged motor)	430890	430890	430336	430889
373	Cone Washer Set	430366	430366	430366	430366
374	D' Washer	430333	430333	430333	430333
375	Cone Motor Nut	471357	471357	471357	471357
380	Capacitor 220-240v	430229 replaced with 430230	0.68µF 430230	1.34µF 430231	2.00µF 430232

** Accessory not a Spare

STANDARD ROOF SPARES

Vent-Axia

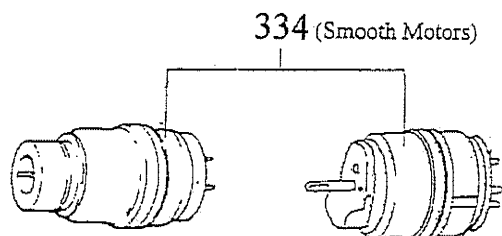
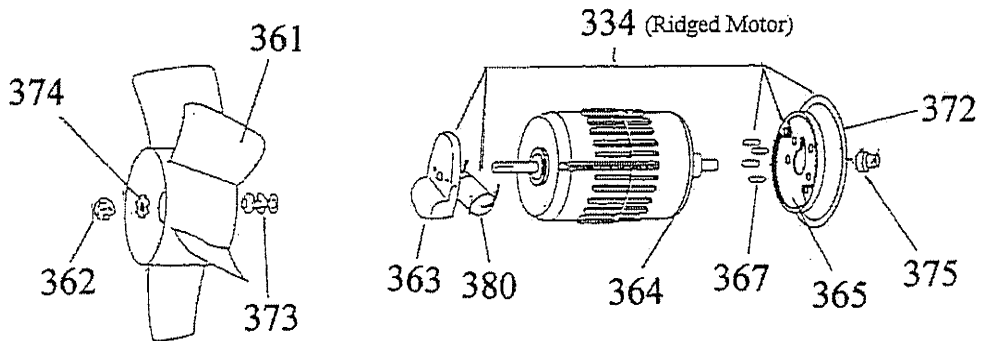
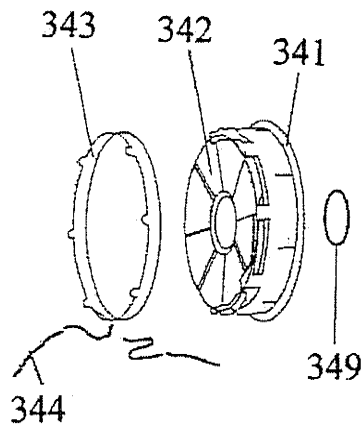
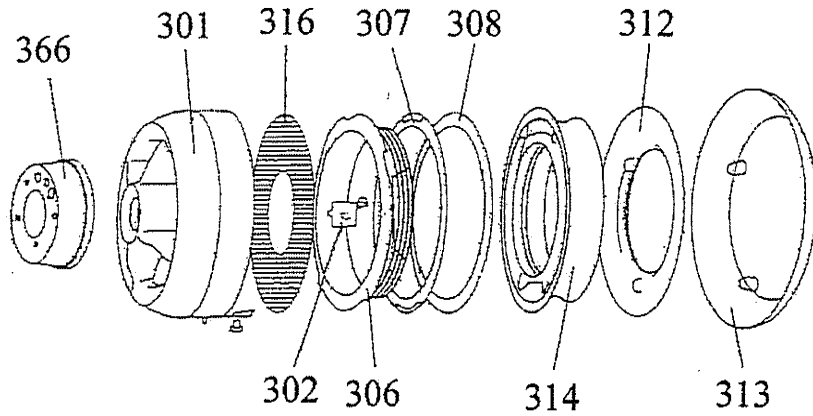

PLEASE NOTE:

These smooth motors have been replaced with the above ridged motor

STANDARD ROOF SPARE PARTS LIST

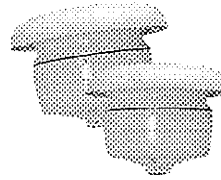

Vent-Axia

Diag	DESCRIPTION	SIZE 6	SIZE 7½	SIZE 9	SIZE 12
301	Housing incl.locking bolt,retainers, sleeves and blanks (ivory)	430031	430032	430033	430034
	Housing incl.locking bolt,retainers & Sleeve (acid/steam resistant)	430039	430040	430041	430042
302	Retainer, Sleeve and Blank set	430047	430048	430049	430050
	Retainer, Sleeve (acid/steam resistant) set	430051	430052	430053	430054
306	Shroud (Ivory)	430075	430076	430077	430078
307	Gasket	430079	430080	430081	430082
308	Seal	430014	430015	430016	430017
312	Deflector (Ivory)	430111	430112	430113	430114
313	Cowl (with nuts and studs) (Ivory)	430119	430120	430121	430122
314	Coaming (Ivory)	430127	430128	430129	430130
316	Protective Grille - Internal **	563106	563107	563109	563112
334	Motor 220-240v (c/w nuts & seating ring)	430274	430274	430275	430276
	Motor Steam Acid 240v	430298	430298	430299	430300
341	Frame Assembly (without flaps) (Ivory)	430146	430147	430148	430149
342	Shutter Flaps for Horizontal Shutter				
	Flap with Red Button weight and Tip weight	Obsolete			
	Flap with Blue weight				430640
	Flap with Yellow Button weight		obsolete	430636	
343	Cam Ring Type R	430158	430159	430160	430161
344	Cord and Knob set Type R	430166	430166	430166	430166
349	Buffer Ring	430339	430339	430340	430341
361	Impeller with 'D' washer	430763	430764	430765	430766
362	Cone/Impeller Nut	430334	430334	430334	430334
	Cone/Motor Nut acid/steam resistant	430364	430364	430364	430364
363	Capacitor Cover c/w screws (smooth mtr)	430213	430213	obsolete	obsolete
	Capacitor Cover c/w screws (ridged mtr)	430899	430899	430900	430901
364	Terminal Block (3-stud)	430356	430356	430356	430356
365	Terminal Block Cover (with screws)	430217	430217	430217	430217
366	Connector Socket (WW, RF & Acid Steam)	430962	430962	430962	430962
367	Motor Connector Pins(set of 3 live,1 earth)	430222	430222	430222	430222
372	Motor Seating Ring (for smooth motor)	430336	430336	430336	430338
	Motor Seating Ring (for ridged motor)	430890	430890	430336	430889
373	Cone Washer Set	430366	430366	430366	430366
374	D' Washer	430333	430333	430333	430333
375	Cone Motor Nut (Window/Roof)	471357	471357	471357	471357
380	Capacitor 220-240v	430229 replace with 430230	0.68µF 430230	1.34µF 430231	2.00µF 430232

** Accessory not a Spare

STANDARD WALL SPARES

Vent-Axia

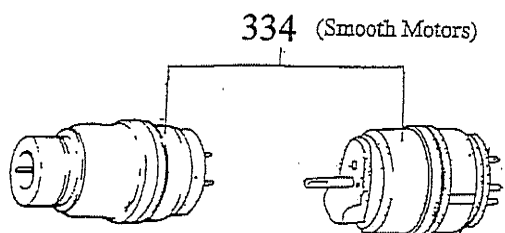
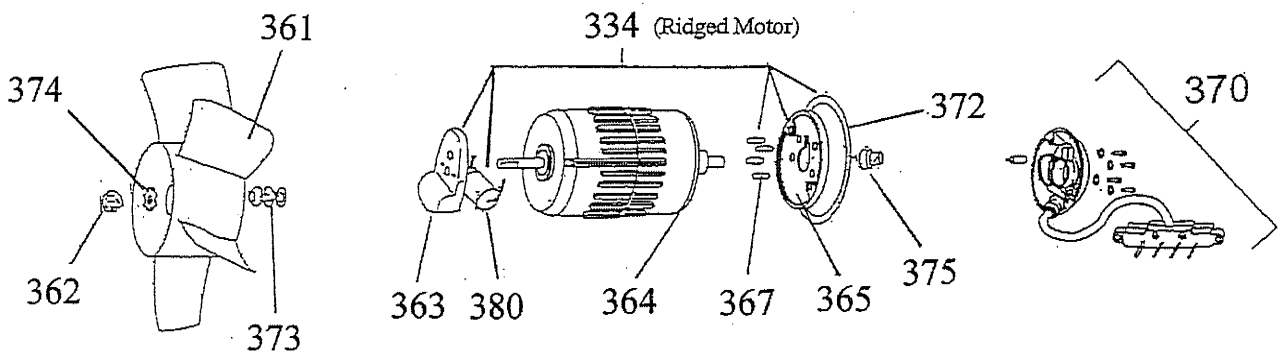
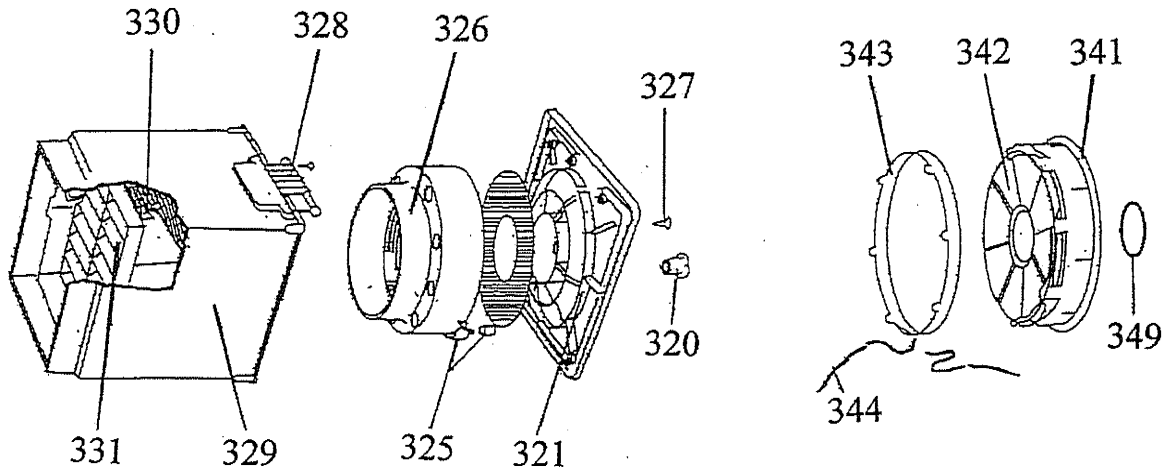

PLEASE NOTE:

These smooth motors have been replaced with the above ridged motor

STANDARD WALL SPARE PARTS LIST

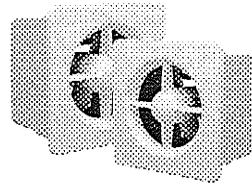

Vent-Axia

Diag	DESCRIPTION	SIZE 6	SIZE 7½	SIZE 9	SIZE 12
316	Protective Grille - Internal **	563106	563107	563109	563112
320	Motor Nut (Wall/Panel)	430365	430365	430365	430365
321	Fascia (incl. Grommets & Motor Nuts)	430982	430983	430984	430985
325	Casing screw set	430135	430135	430135	430135
326	Casing (incl. Casing screw set)	430136	430137	430138	430139
327	Plastic fascia screws (set of 4)	430140	430140	430140	430140
328	Socket Assembly with screws	430141	430141	430141	430141
329	Lining (incl. fasteners and screws)	430022	440075	440075	440076
330	Fastener & Fastener screws (set of 2)	430023	430023	430023	430023
331	Louvre	430024	430025	430025	430026
334	Motor 220-240v (c/w nuts & seating ring)	430274	430274	430275	430276
	Motor Steam Acid 240v	430298	430298	430299	430300
341	Frame Assembly (without flaps) (Ivory)	430146	430147	430148	430149
342	Flap Plain	430629	430630		
	Flap with Red & Blue weight	430632			
	Flap with Red weight		430635	430638	430641
	Flap with Blue weight		430634	430639	430640
	Flap with Green weight	430631	430633	430637	430642
	Flap with Yellow weight			430636	
343	Cam Ring Type R	430158	430159	430160	430161
344	Cord and Knob set Type R	430166	430166	430166	430166
349	Buffer Ring	430339	430339	430340	430341
361	Impeller with 'D' washer	430763	430764	430765	430766
362	Cone/Impeller Nut	430334	430334	430334	430334
	Cone/Motor Nut acid/steam resistant	430364	430364	430364	430364
363	Capacitor Cover c/w screws (smooth motor)	430213	430213	430214	430215
	Capacitor Cover c/w screws (ridged motor)	430899	430899	430900	430901
364	Terminal Block (3-stud)	430356	430356	430356	430356
365	Terminal Block Cover (with screws)	430217	430217	430217	430217
366	Connector Socket (WW, RF & Acid Steam)	430962	430962	430962	430962
370	Plug Lead Assy (with screws) - Wall	430226	430227	430227	430228
372	Motor Seating Ring (for smooth motor)	430336	430336	430336	430338
	Motor Seating Ring (for ridged motor)	430890	430890	430336	430889
373	Cone Washer Set	430366	430366	430366	430366
374	D' Washer	430333	430333	430333	430333
380	Capacitor 220-240v	430229 replace with 430230	0.68µF 430230	1.34µF 430231	2.00µF 430232

** Accessory not a Spare

STANDARD PANEL SPARES

Vent-Axia

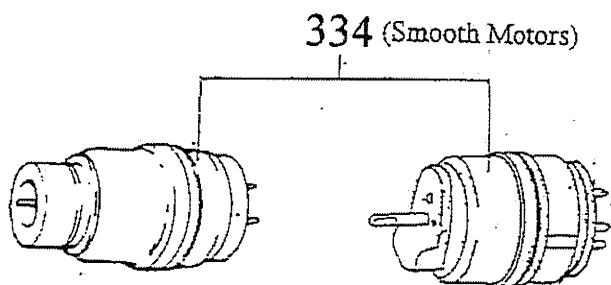
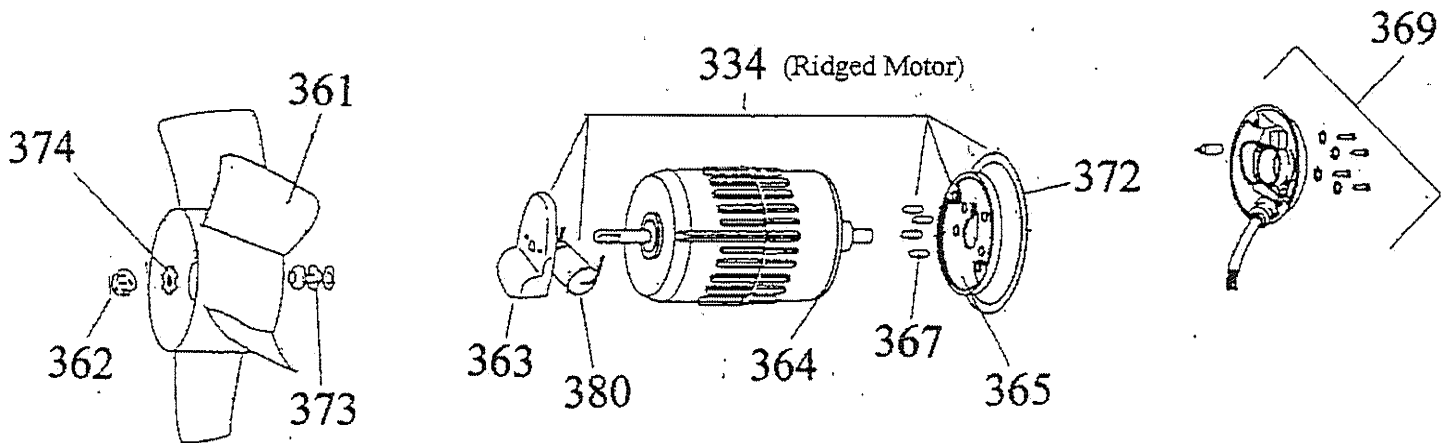
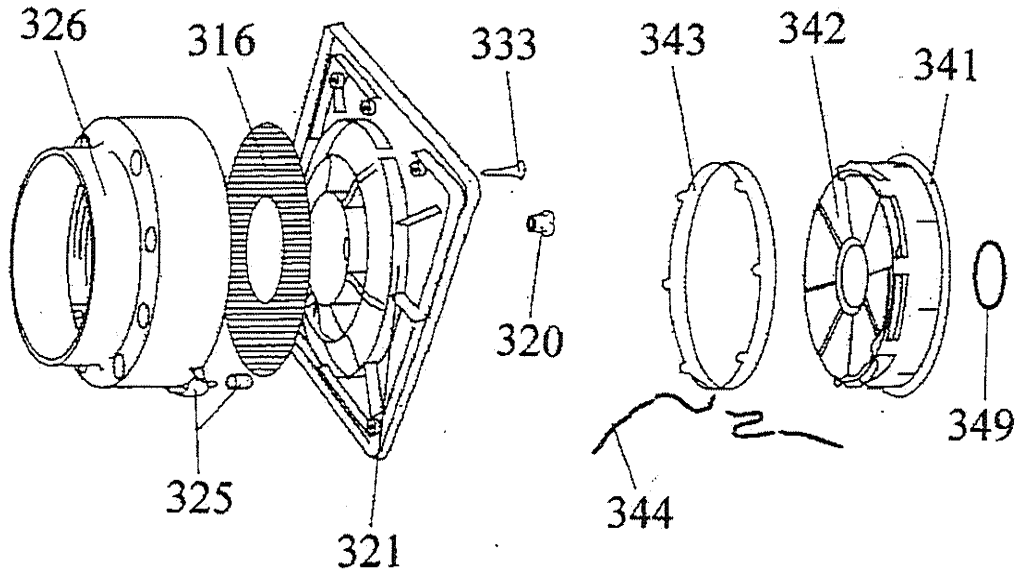

PLEASE NOTE:

These smooth motors have been replaced with the above ridged motor

STANDARD PANEL SPARE PARTS LIST

Vent-Axia

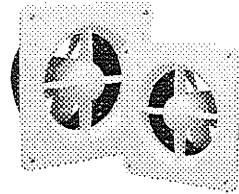

Diag	DESCRIPTION	SIZE 6	SIZE 7½	SIZE 9	SIZE 12
316	Protective Grille - Internal **	563106	563107	563109	563112
320	Motor Nut	430365	430365	430365	430365
321	Fascia (incl.Grommets & Motor Nuts)	430982	430983	430984	430985
325	Casing screw set	430135	430135	430135	430135
326	Casing (incl. Casing screw set)	430136	430137	430138	430139
333	Plated Fascia screws (set of 4)	440081	440081	440081	440081
334	Motor 220-240v (c/w nuts & seating ring)	430274	430274	430275	430276
	Motor Steam Acid 240v	430298	430298	430299	430300
341	Frame Assembly (without flaps) (Ivory)	430146	430147	430148	430149
342	Flap Plain	430629	430630		
	Flap with Red & Blue weight	430632			
	Flap with Red weight		430635	430638	430641
	Flap with Blue weight		430634	430639	430640
	Flap with Green weight	430631	430633	430637	430642
	Flap with Yellow weight			430636	
343	Cam Ring Type R	430158	430159	430160	430161
344	Cord and Knob set Type R	430166	430166	430166	430166
349	Buffer Ring	430339	430339	430340	430341
361	Impeller with 'D' washer	430763	430764	430765	430766
362	Cone/Impeller Nut	430334	430334	430334	430334
	Cone/Motor Nut acid/steam resistant	430364	430364	430364	430364
363	Capacitor Cover c/w screws (smooth mtr)	430213	430213	obsolete	obsolete
	Capacitor Cover c/w screws (ridged mtr)	430899	430899	430900	430901
364	Terminal Block (3-stud)	430356	430356	430356	430356
365	Terminal Block Cover (with screws)	430217	430217	430217	430217
369	Motor Lead Assy (with screws)	430225	430225	430225	430225
372	Motor Seating Ring (for smooth motor)	430336	430336	430336	430338
	Motor Seating Ring (for ridged motor)	430890	430890	430336	430889
373	Cone Washer Set	430366	430366	430366	430366
374	D' Washer	430333	430333	430333	430333
380	Capacitor 220-240v	430229 replace with 430230	0.68µF 430230	1.34µF 430231	2.00µF 430232

** Accessory not a Spare