

BACnet connection C8

BACNET CONNECTION AND SETTINGS

BACnet is a standard communication protocol for Building Automation and Control (BAC) networks that can be used to monitor and control Komfovent air handling units with C8 controller. The supported Data Link Layer is BACnet / IP.

BACnet protocol works via Ethernet interface, connection is provided to RJ-45 socket (Pic.1) on the C8 controller (CAT5 cable is recommended):

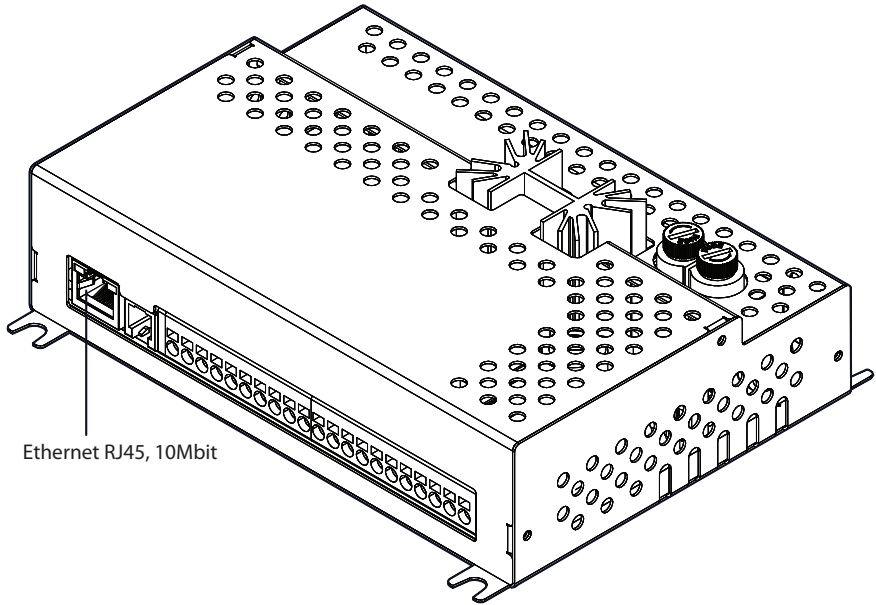

Picture 1. C8 controller board

Below is default network settings of the C8 controller. These can be changed according to the building network software requirements. To do so, it is needed to connect a laptop to the integrated webservice of C8 controller:

CONNECTIVITY

DHCP	<input checked="" type="checkbox"/> Off	<input type="checkbox"/> On		
IP address	192	168	0	60
Subnet mask	255	255	255	0
Gateway	192	168	0	1
BACnet ID	60			
Modbus ID	254			
RS-485	19200 baud	▼	8E1	▼

Picture 2. Connectivity settings

C8 controller IP can also be viewed and changed on the control panel – from *Main menu* go to *Advanced settings*->*Connectivity*:

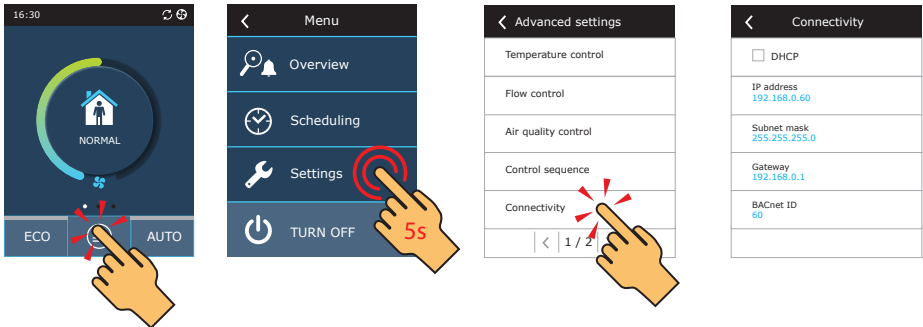

Picture 3. Connectivity settings on C6.1 control panel display

BACnet Interoperability Building Blocks Supported

Data sharing	DS-RP-B	Read Property
	DS-RPM-B	Read Property Multiple
	DS-WP-B	Write Property
Device management	DM-DCC-B	Device Communication Control
	DM-DDB-B	Dynamic Device Binding
	DM-DOB-B	Dynamic Object Binding
	DM-TS-B	Time Synchronization

Standard Object Types Supported:

Object type	Properties
Device	Object_Identifier, Object_Name, Object_Type, System_Status, Vendor_Name, Vendor_Identifier, Model_Name, Firmware_Revision, Application_Software_Version, Protocol_Version, Protocol_Revision, Protocol_Services_Supported, Protocol_Object_Types_Supported, Object_List, Max_APDU_Length_Accepted, Segmentation_Supported, APDU_Timeout, Number_Of_APDU_Retries, Device_Address_Binding, Database_Revision, Property_List; Description, Local_Date, Local_Time
Analog value	Object_Identifier, Object_Name, Object_Type, Present_Value, Status_Flags, Event_State, Out_Of_Service, Units, Property_List; Reliability
Binary value	Object_Identifier, Object_Name, Object_Type, Present_Value, Status_Flags, Event_State, Out_Of_Service, Property_List; Incative_Text, Active_Text
Date value	Object_Identifier, Object_Name, Object_Type, Present_Value, Status_Flags, Property_List
Multi-state value	Object_Identifier, Object_Name, Object_Type, Present_Value, Status_Flags, Event_State, Out_Of_Service, Number_Of_States, Property_List; State_Text
Positive integer value	Object_Identifier, Object_Name, Object_Type, Present_Value, Status_Flags, Units, Property_List; Reliability
Time value	Object_Identifier, Object_Name, Object_Type, Present_Value, Status_Flags, Property_List

Objects:

Analog value			
Object name	Object instance	Present value	
		Range/values/units	Access
AWAY: setpoint	0	5.0 – 40.0 [°C]	W
NORMAL: setpoint	1	5.0 – 40.0 [°C]	W
INTENSIVE: setpoint	2	5.0 – 40.0 [°C]	W
BOOST: setpoint	3	5.0 – 40.0 [°C]	W
KITCHEN: setpoint	4	5.0 – 40.0 [°C]	W

Analog value			
Object name	Object instance	Present value	
		Range/values/units	Access
FIREPLACE: setpoint	5	5.0 – 40.0 [°C]	W
OVERRIDE: setpoint	6	5.0 – 40.0 [°C]	W
HOLIDAYS: setpoint	7	5.0 – 40.0 [°C]	W
ECO: minimum supply air temperature	8	5.0 – 40.0 [°C]	W
ECO: maximum supply air temperature	9	5.0 – 40.0 [°C]	W
AIR QUALITY: temperature setpoint	10	5.0 – 40.0 [°C]	W
INFO: supply temperature	11	[°C]	R
INFO: extract temperature	12	[°C]	R
INFO: outdoor temperature	13	[°C]	R
INFO: water temperature	14	[°C]	R
INFO: panel 1 temperature	15	[°C]	R
INFO: panel 2 temperature	16	[°C]	R
INFO: current supply fan intensity	17	[%]	R
INFO: current extract fan intensity	18	[%]	R
INFO: heat exchanger	19	[%]	R
INFO: electric heater	20	[%]	R
INFO: analog output 0-10V	21	[%]	R
INFO: DX unit	22	[%]	R

Binary value				
Object name	Object instance	Present value		
		Range/values/units	Access	
CONTROL: ON/OFF status	0	0 – off	1 – on	W
CONTROL: ECO mode	1	0 – off	1 – on	W
CONTROL: AUTO mode	2	0 – off	1 – on	W
AWAY: heating	3	0 – off	1 – on	W
NORMAL: heating	4	0 – off	1 – on	W
INTENSIVE: heating	5	0 – off	1 – on	W
BOOST: heating	6	0 – off	1 – on	W
KITCHEN: heating	7	0 – off	1 – on	W
FIREPLACE: heating	8	0 – off	1 – on	W
OVERRIDE: heating	9	0 – off	1 – on	W
HOLIDAYS: heating	10	0 – off	1 – on	W
ECO: free heating/cooling	11	0 – off	1 – on	W
ECO: heating enable denied	12	0 – off	1 – on	W
ECO: cooling enable denied	13	0 – off	1 – on	W
ECO: non stop recuperation	14	0 – off	1 – on	W
AIR QUALITY: enabled	15	0 – disabled	1 – enabled	W
AIR QUALITY: heating	16	0 – off	1 – on	W
ALARMS: return water temperature low	17	0 – no	1 – yes	R
ALARMS: low supply air temperature	18	0 – no	1 – yes	R
ALARMS: high supply air temperature	19	0 – no	1 – yes	R
ALARMS: electric heater overheat	20	0 – no	1 – yes	R
ALARMS: heat exchanger failure	21	0 – no	1 – yes	R
ALARMS: heat exchanger icing	22	0 – no	1 – yes	R
ALARMS: internal fire alarm	23	0 – no	1 – yes	R

Binary value				
Object name	Object instance	Present value		
		Range/values/units		Access
ALARMS: external fire alarm	24	0 – no	1 – yes	R
ALARMS: temperature sensor failure	25	0 – no	1 – yes	R
ALARMS: controller failure	26	0 – no	1 – yes	R
ALARMS: service mode	27	0 – no	1 – yes	R
ALARMS: clogged air filters	28	0 – no	1 – yes	R
ALARMS: heat exchanger low efficiency	29	0 – no	1 – yes	R
ALARMS: fire dampers communication error	30	0 – no	1 – yes	R
ALARMS: fire dampers failure	31	0 – no	1 – yes	R
INFO: heating	32	0 – off	1 – on	R
INFO: cooling	33	0 – off	1 – on	R
CLEAN FILTERS CALIBRATION	34	0 – no	1 – yes	W

Date value				
Object name	Object instance	Present value		
		Range/values/units		Access
HOLIDAYS: from	0	2017-01-01 – 2035-12-31		W
HOLIDAYS: till	1	2017-01-01 – 2035-12-31		W

Multi-state value				
Object name	Object instance	Present value		
		Range/values/units		Access
CONTROL: auto mode control	0	1 – scheduling	2 – air quality	R
CONTROL: current mode	1	1 – standby 2 – away 3 – normal 4 – intensive 5 – boost 6 – kitchen	7 – fireplace 8 – override 9 – holiday 10 – auto 11 – off	W [2-5]
SCHEDULER: operation program	2	1 – stay at home 2 – working week	3 – office 4 – custom	W
SCHEDULER: next mode	3	1 – standby 2 – away 3 – normal	4 – intensive 5 – boost	R
SCHEDULER: next mode weekday	4	1 – today 2 – mo 3 – tu 4 – we	5 – th 6 – fr 7 – sa 8 – su	R
CONTROL: temperature control	5	1 – supply 2 – extract	3 – room 4 – balance	W
CONTROL SEQUENCE: stage 1	6	1 – none 2 – external coil	3 – electric heater 4 – external DX unit	W
CONTROL SEQUENCE: stage 2	7			W
CONTROL SEQUENCE: stage 3	8			W
SETTINGS: coil type	9	1 – hot water	2 – cold water	W

Multi-state value			
Object name	Object instance	Present value	
		Range/values/units	Access
SETTINGS: language	10	1 – en 2 – lt 3 – ru 4 – pl 5 – sk 6 – de 7 – fr 8 – hu 9 – it 10 – ee	11 – nl 12 – lv 13 – pt 14 – se 15 – fi 16 – hr 17 – sl 18 – cz 19 – dk W
VERRIDE: mode	11	1 – all time 2 – if on	3 – if off W
HOLIDAYS: microventilation	12	1 – 1 t. per day 2 – 2 t. per day	3 – 3 t. per day 4 – 4 t. per day W
AIR QUALITY: sensor type B8	13	1 – none 2 – CO2	3 – VOC 4 – RH W
RESET SETTINGS	14	1 – none 2 – "away" 3 – "normal" 4 – "intensive" 5 – "boost" 6 – "holidays"	7 – "override" 8 – "kitchen" 9 – "fireplace" 10 – air quality 11 – eco 12 – advanced W

Positive integer value			
Object name	Object instance	Present value	
		Range/values/units	Access
CONNECTIVITY: IP address	0	0 – 4294967295	W
CONNECTIVITY: mask	1	0 – 4294967295	W
AWAY: supply flow	2	20 – 100 [%]	W
AWAY: extract flow	3	20 – 100 [%]	W
NORMAL: supply flow	4	20 – 100 [%]	W
NORMAL: extract flow	5	20 – 100 [%]	W
INTENSIVE: supply flow	6	20 – 100 [%]	W
INTENSIVE: extract flow	7	20 – 100 [%]	W
BOOST: supply flow	8	20 – 100 [%]	W
BOOST: extract flow	9	20 – 100 [%]	W
KITCHEN: supply flow	10	20 – 100 [%]	W
KITCHEN: extract flow	11	20 – 100 [%]	W
FIREPLACE: supply flow	12	20 – 100 [%]	W
FIREPLACE: extract flow	13	20 – 100 [%]	W
VERRIDE: supply flow	14	20 – 100 [%]	W
VERRIDE: extract flow	15	20 – 100 [%]	W
KITCHEN: timer	16	0 – 300 [min]	W
FIREPLACE: timer	17	0 – 300 [min]	W
VERRIDE: timer	18	0 – 300 [min]	W
AIR QUALITY: air quality setpoint	19	0 – 2000 [ppm] 0 – 100 [%]	W
AIR QUALITY: humidity setpoint	20	0 – 100 [%]	W
AIR QUALITY: minimum intensity	21	0, 20 – 100 [%]	W
AIR QUALITY: maximum intensity	22	0, 20 – 100 [%]	W
AIR QUALITY: check period	23	1 – 24 [h]	W

Positive integer value			
Object name	Object instance	Present value	
		Range/values/units	Access
ALARMS: active alarms count	24	0 – 10	W [39366 resets alarms]
ALARMS: alarm history count	25	0 – 50	R
INFO: current supply flow	26	[%]	R
INFO: current extract flow	27	[%]	R
INFO: filters impurity	28	[%]	R
INFO: air dampers	29	[%]	R
INFO: air quality/humidity sensor	30	[ppm, %]	R
INFO: panel 1 humidity	31	[%]	R
INFO: panel 2 humidity	32	[%]	R
INFO: panel 1 air quality	33	[ppm]	R
INFO: panel 2 air quality	34	[ppm]	R
EFFICIENCY/STATUS: heater power	35	[W]	R
OPERATION COUNTERS: supply air fan (day)	36	[h]	R
OPERATION COUNTERS: supply air fan (month)	37	[h]	R
OPERATION COUNTERS: supply air fan (total)	38	[h]	R
OPERATION COUNTERS: exhaust air fan (day)	39	[h]	R
OPERATION COUNTERS: exhaust air fan (month)	40	[h]	R
OPERATION COUNTERS: exhaust air fan (total)	41	[h]	R
OPERATION COUNTERS: electric heater (day)	42	[h]	R
OPERATION COUNTERS: electric heater (month)	43	[h]	R
OPERATION COUNTERS: electric heater (total)	44	[h]	R
OPERATION COUNTERS: heat exchanger (day)	45	[h]	R
OPERATION COUNTERS: heat exchanger (month)	46	[h]	R
OPERATION COUNTERS: heat exchanger (total)	47	[h]	R

Time value			
Object name	Object instance	Present value	
		Range/values/units	Access
SCHEDULER: next mode start time	0	00:00 – 24:00	R

UAB KOMFOVENT

SERVICE AND SUPPORT

Phone: +370 5 200 8000
service@komfovent.com

Komfovent AB

Ögärdesvägen 12A
433 30 Partille, Sverige
Phone: +46 31 487 752
info_se@komfovent.com
www.komfovent.se

Komfovent Oy

Muuntotie 1 C1
FI-01 510 VANTAA
Phone: +358 20 730 6190
toimisto@komfovent.com
www.komfovent.com

Komfovent GmbH

Konrad-Zuse-Str. 2a, 42551 Velbert,
Deutschland
Phone: +49 0 2051 6051180
info@komfovent.de
www.komfovent.de

SIA Komfovent

Bukaišu iela 1, LV-1004 Rīga
Phone: +371 24 664433
info@komfovent.lv
www.komfovent.lv

Vidzemes filiāle

Alejas iela 12A, LV-4219 Valmiermuiža,
Valmieras pagasts, Burtnieku novads
Phone: +371 29 358 145
kristaps.zaicevs@komfovent.com
www.komfovent.lv

www.komfovent.com

PARTNERS

AT	J. PICHLER Gesellschaft m. b. H.	www.pichlerluft.at
BE	Ventilair group	www.ventilairgroup.com
	ACB Airconditioning	www.acbairco.be
CZ	REKUVENT s.r.o.	www.rekuvent.cz
CH	WESCO AG	www.wesco.ch
	SUDCLIMATAIR SA	www.sudclimatair.ch
CH / LI	CLIMAIR GmbH	www.climair.ch
	Trivent AG	www.trivent.com
DK	Øland A/S	www.oeland.dk
EE	BVT Partners	www.bvtpartners.ee
FR	ATIB	www.atib.fr
HR	Microclima	www.microclima.hr
HU	AIRVENT Légtechnikai Zrt.	www.airvent.hu
	Gevent Magyarorszáig Kft.	www.gevent.hu
	Merkapt	www.merkapt.hu
IR	Fantech Ventilation Ltd	www.fantech.ie
IS	Blikk & Tækniþjónustan ehf	www.bogt.is
	Hitataekni ehf	www.hitataekni.is
IT	Icaria srl	www.icariavmc.it
NL	DECIPOL-Vortvent	www.vortvent.nl
NO	Ventilution AS	www.ventilution.no
	Ventistål AS	www.ventistal.no
	Thermo Control AS	www.thermocontrol.no
PL	Ventia Sp. z o.o.	www.ventia.pl
SE	Nordisk Ventilator AB	www.nordiskventilator.se
SI	Agregat d.o.o	www.agregat.si
SK	TZB produkt, s.r.o.	www.tzbprodukt.sk
UA	TD VECON LLC	www.vecon.ua



Buitendijks 63, 3356 LX Papendrecht

Tel: +31(0)85-782 64 00

Email: info@vortvent.nl